

Espace

N.T. 2996A

JE0 G

SPECIAL NOTES FOR ESPACE VEHICLES WITH L7X ENGINES AND LM0 AUTOMATIC TRANSMISSION

For sections not described in this note, refer to M.R. 315.

77 11 200 595

JUNE 1998

Edition Anglaise

"The repair methods given by the manufacturer in this document are based on the technical specifications current when it was prepared.

The methods may be modified as a result of changes introduced by the manufacturer in the production of the various component units and accessories from which his vehicles are constructed."

All copyrights reserved by Renault.

Copying or translating, in part or in full, of this document or use of the service part reference numbering system is forbidden without the prior written authority of Renault.

Contents

	Page		Page
0		General vehicle information	
03		TOWING	
		Towing automatic transmission vehicles	03-1
05		DRAINING - FILLING	
		Engine	05-1
		Automatic transmission	05-2
07		VALUES AND SETTINGS	
		Capacities - Grades	07-1
		Accessories belt	07-3
		Tightening the cylinder head	07-4
1		Engine and peripherals	
10		ENGINE AND PERIPHERALS ASSEMBLY	
		Identification	10-1
		Engine oil pressure	10-2
		Engine - Gearbox	10-3
		Sump	10-9
		Oil pump	10-10
11		TOP AND FRONT OF ENGINE	
		Timing belt	11-1
		Cylinder heads	11-13
12		FUEL MIXTURE	
		Specifications	12-1
		Throttle body	12-4
		Inlet manifold	12-5
		Front exhaust manifold	12-9
		Rear exhaust manifold	12-11
13		FUEL SUPPLY - PUMPS - PREHEATING	
		Fuel supply	
		Air inlet	13-1
		Injector gallery	13-2
		Supply pressure	13-4
		Pump	
		Mechanical power assisted steering pump	13-5
14		ANTI POLLUTION	
		Fuel vapour rebreathing	14-1
		Oil vapour rebreathing	14-4
16		STARTING - CHARGING	
		Alternator	16-1
		Starter motor	16-3
17		IGNITION - INJECTION	
		Ignition	
		Static ignition	17-1
		Replacing the plugs	17-2
		Injection	
		General	17-4
		Location of components	17-5
		Immobiliser function	17-9
		Injection fault warning light	17-10
		Injection/automatic transmission programming	17-11
		Injection/air conditioning programming	17-12
		Idle speed correction	17-13
		Adaptive idle speed correction	17-14
		Richness regulation	17-15
		Adaptive richness correction	17-16
		Fault finding - Introduction	17-18
		Fault finding - XR25 fiche	17-22
		Fault finding - Interpretation of XR25 bargraphs	17-25
		Fault finding - Status and parameter check	17-52
		Fault finding - Status and parameter interpretation	17-57
		Fault finding - Customer complaints	17-62
		Fault finding - Fault charts	17-63
		Fault finding - Aid	17-67

Contents

	Page
19 COOLING - EXHAUST - FUEL TANK - ENGINE SUSPENSION	
Cooling	
Specifications	19-1
Diagram	19-2
Filling - bleeding	19-3
Thermostat	19-4
Water pump	19-5
Cooling assembly	19-8
Engine suspension	
Suspended engine mountings	19-11

2 Automatic transmission

	Page
23 AUTOMATIC TRANSMISSION	
General	23- 1
Consumables	23- 2
Components to be systematically replaced	23- 2
Oil	23- 2
Hydraulic distributor	23- 4
Removal - refitting	23- 6
Differential output seal	23- 9
Converter seal	23- 10
Multifunction switch	23- 12
Speed sensor	23- 13
Oil temperature sensor	23- 14
Solenoid valves	23- 15
Speedometer torque	23- 16

3 Chassis

37 AUTOMATIC TRANSMISSION CONTROL

Adjusting the control lever	37-1
-----------------------------	------

6 Air conditioning

62 AIR CONDITIONING

Condenser	62-1
Dehydration canister	62-2
Connecting pipes	62-3
Compressor	62-7

TOWING

Automatic transmission

03

OBSERVE THE LEGAL TOWING REQUIREMENTS OF THE COUNTRY YOU ARE IN.

NEVER USE THE DRIVESHAFTS AS ATTACHMENT POINTS.

The towing points may only be used for towing the vehicle on the road. They should never be used for removing the vehicle from a ditch or for any other similar breakdown operation or to lift the vehicle, either directly or indirectly.

They may be used for winching purposes by placing a shackle between the towing eye and the winch hook.

FRONT

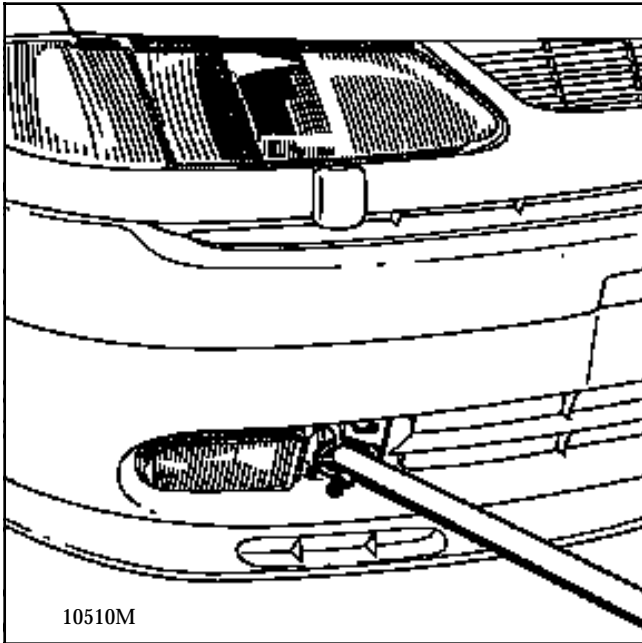

REAR

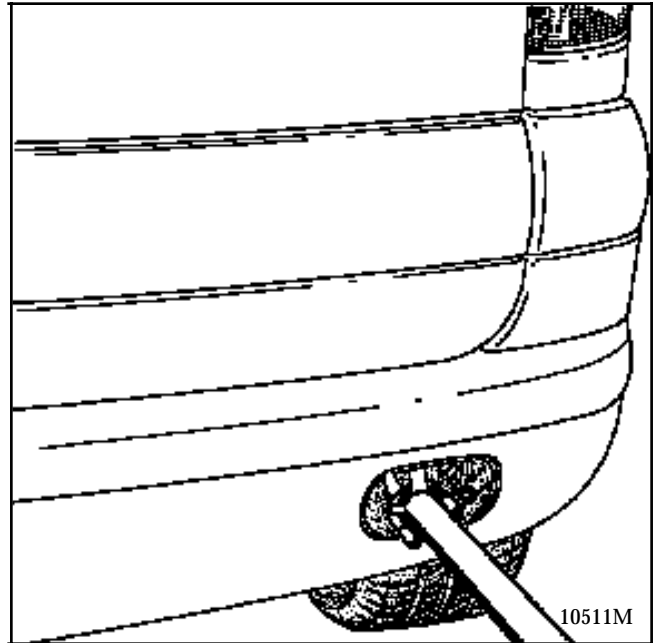

Remove the ring cover from the left of the front right hand additional headlight or the rear cover on the right hand side of the bumper and fit the shackle into the ring.

The front of the vehicle should be raised, but if this is not possible, the vehicle may be towed with the wheels on the ground under exceptional circumstances, under the following conditions:

Only tow the vehicle at a speed less than 43.5 mph (70 km/h) and for not more than 62 miles (100 km) (gear lever in "N").

SECURING ON TRANSPORTER VEHICLES

Use the front left hand side member ring and the two eyes located behind the rear bumper.

DRAINING - FILLING Engine

05

TOOLING REQUIRED

Engine drain plug spanner

DRAINING:

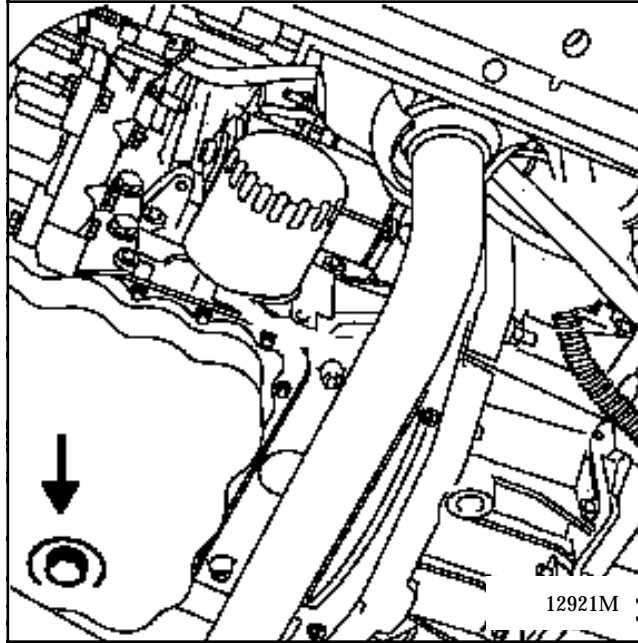

OIL CHANGE INTERVALS

The automatic transmission is filled for life and therefore does not require maintenance.

Only the level should be topped up in the event of a slight leak.

Capacity in litres

Total volume	8 LTS
--------------	-------

NOTE: The oil lubricates the mechanism and the final drive.

DRAIN PLUG

TIGHTENING TORQUE (in daN.m)	
Drain plug	3.5

SPECIAL NOTE:

The automatic transmission should be drained when the oil is warm, to prevent impurities entering the system.

Draining is carried out by removing plug (A).

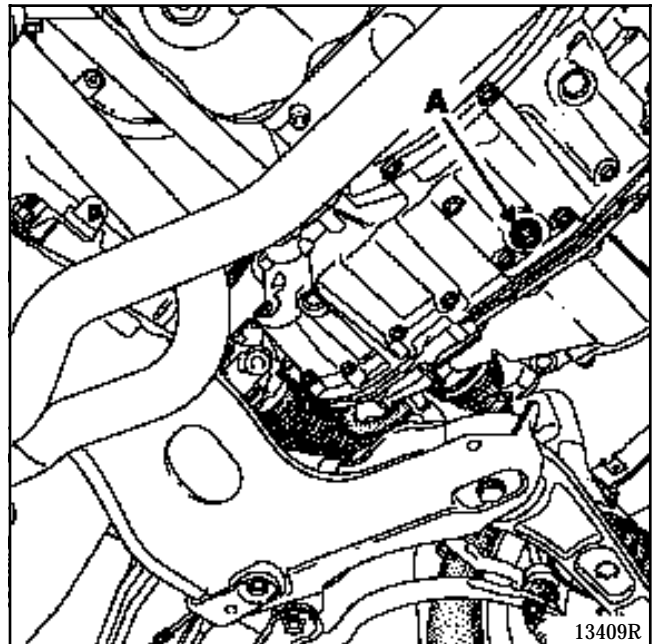

Measure the quantity of oil drained (this measurement is used as a reference for refilling).

FILLING - LEVELS

Use the marks on the dipstick to top up the oil level (D).

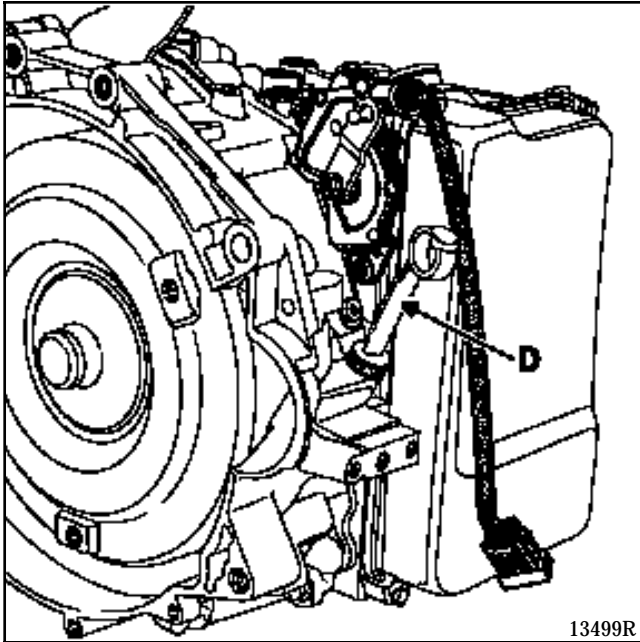

13499R

Use a funnel fitted with a 15/100 filter mesh to prevent the introduction of foreign bodies.

The level **MUST** be checked using the following method.

- 1 - Place the vehicle on a level surface.
- 2 - Fill the automatic transmission with the same amount of oil as was noted during draining to give an approximate level.
- 3 - Run the engine at idle speed.
- 4 - Connect the XR25, enter:

then

- 5 - When a temperature of $80^{\circ}\text{C} \pm 1^{\circ}\text{C}$ is reached, remove the dipstick, the level should be within zone B.

If this is not the case, add more oil with the engine running.

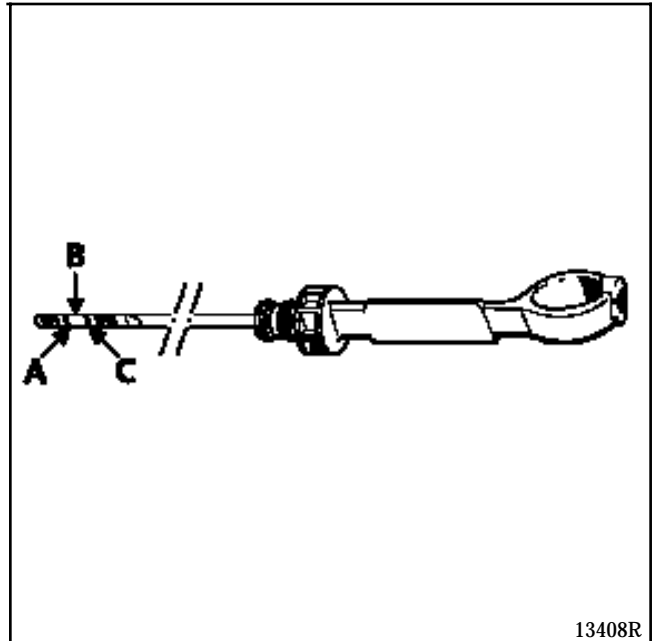

13408R

Mark **A** : MINIMUM

Zone **B** : Normal level

Mark **C** : MAXIMUM

VALUES AND SETTINGS

Capacity - Grades

07

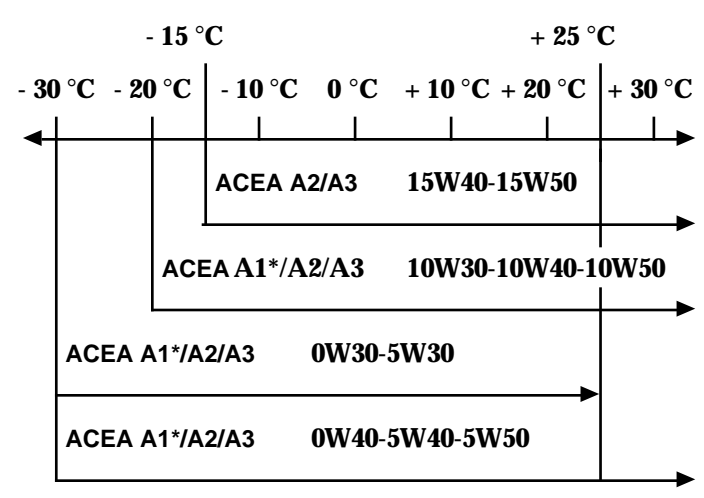
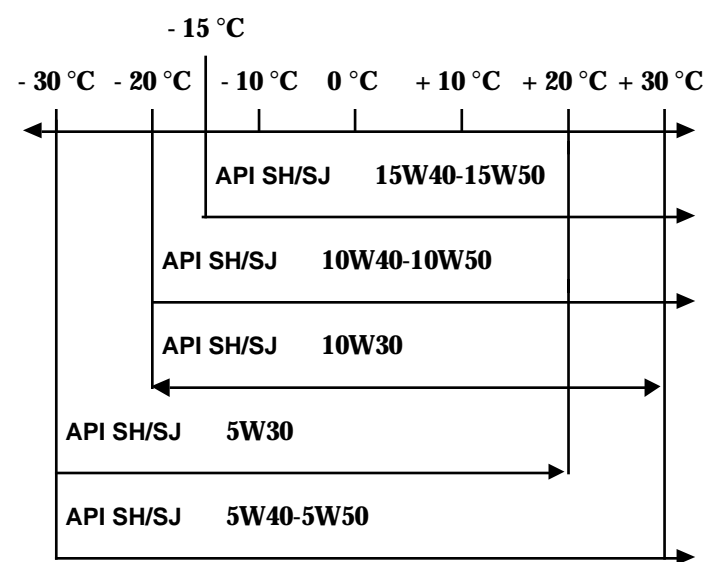
Components	Capacity in litres (environ *)	Grade
Petrol engine (oil)	When draining	<p>E.E.C.</p> 
	L7X	<p>Other countries</p> 

* Adjust using the dipstick
 (1) After replacing the oil filter

VALUES AND SETTINGS

Capacity - Grades

07

Components	Capacity in litres	Grade	Special notes
LM0 automatic transmission	8	All countries: oil reference number SODICAM 77 11 172 226 or ESSO LT71141 . The automatic transmission is lubricated for life.	
L7X cooling circuit	approximately 7	GLACÉOL RX (type D) Only add coolant of the same type	Protection down to - 20°±2°C for hot, temperate and cold countries. Protection down to - 37°±2°C for extreme cold countries.

SPECIAL NOTE FOR REMOVING THE ACCESSORIES BELT BELT

Slacken bolts (1) and (2).

Hold the dynamic tensioner in tension using the hexagonal wrench (3).

Slacken the bolt (4) until the conical part (5) passes the oblong hole of the dynamic tensioner.

Remove the belt.

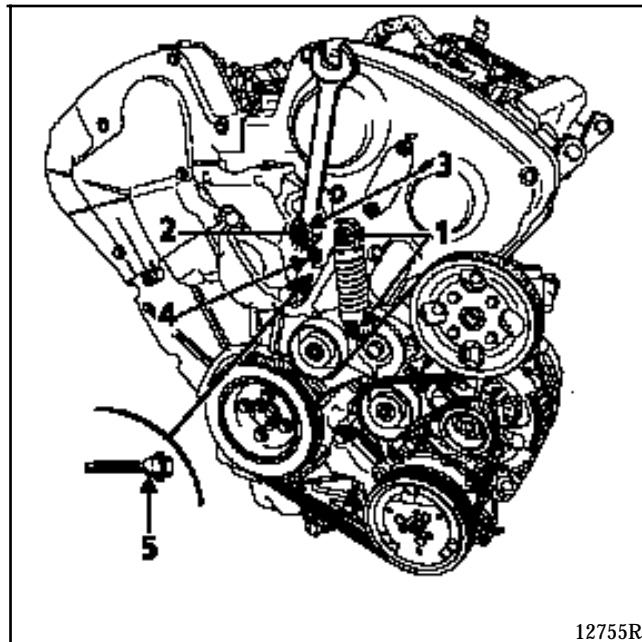

When refitting, place the dynamic tensioner in the operating position towards the right and tighten bolts (4) then (2) to a torque of **2.5 daN.m**.

NOTE: do not refit a belt once it has been removed. Replace it.

METHOD FOR TIGHTENING THE CYLINDER HEAD

Pretighten each bolt in turn to **2 daN.m** in the recommended order.

Completely slacken bolt (1).

Retighten the bolt (1) to **1.5 daN.m**, then angle tighten to **225°**.

Carry out the same procedure for the other bolts.

Tighten the other cylinder head in the same way.

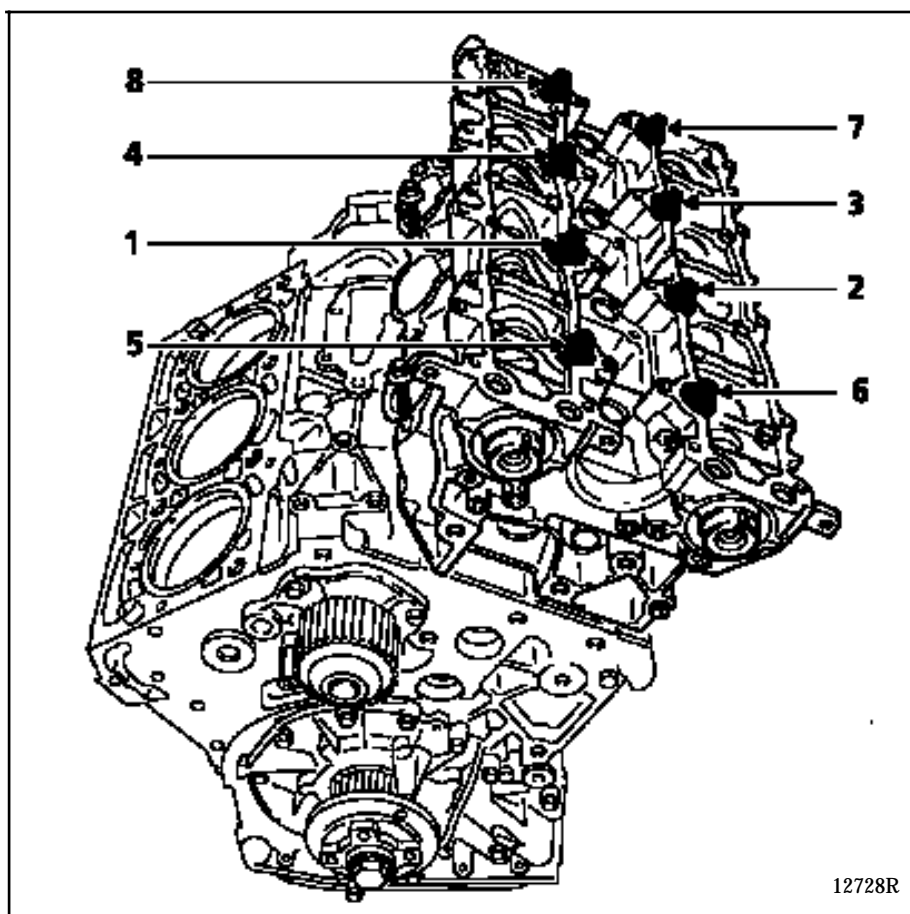

Thickness of the cylinder head gasket:

Nominal dimension=**1.45 ± 0.04 mm**.

Repair dimension=**1.65 ± 0.04 mm**.

ENGINE AND PERIPHERALS ASSEMBLY

Identification

10

Vehicle type	Engine	Automatic transmission	Capacity (cm ³)	Bore (mm)	Stroke (mm)	Ratio
JE0 G	L7X	LM0	2 946	87	82.6	10.5/1

Consult Workshop Repair Manual: **Mot. L (E)**

CHECKING

SPECIAL TOOLING REQUIRED		
Mot.	836 -05	Oil pressure testing kit
Mot.	1437	Pressure testing connection

The oil pressure must be checked when the engine is warm (approximately 80°C).

Composition of the kit **Mot. 836-05**.

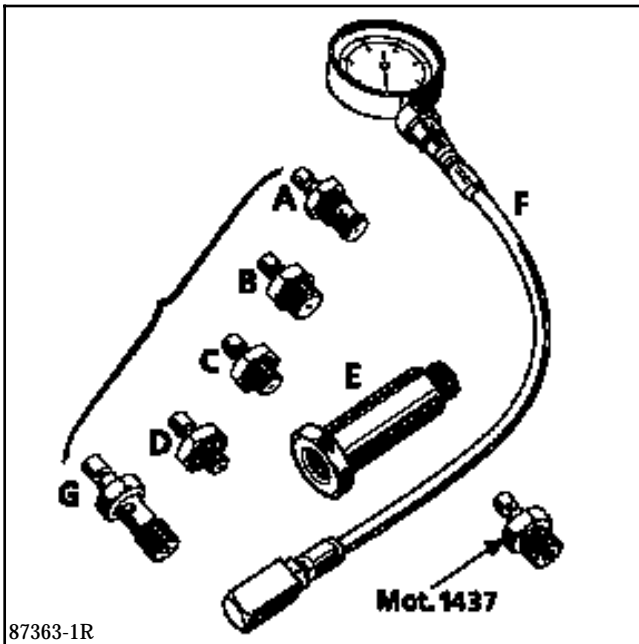

Use:

Engine L : F + **Mot. 1437**

Oil pressure

Idle speed **2 bars**
3000 rpm. **5 bars**

Place the vehicle on a lift, and disconnect the battery.

Remove the oil pressure switch.

Fit tool **Mot. 1437**, along with the oil pressure gauge.

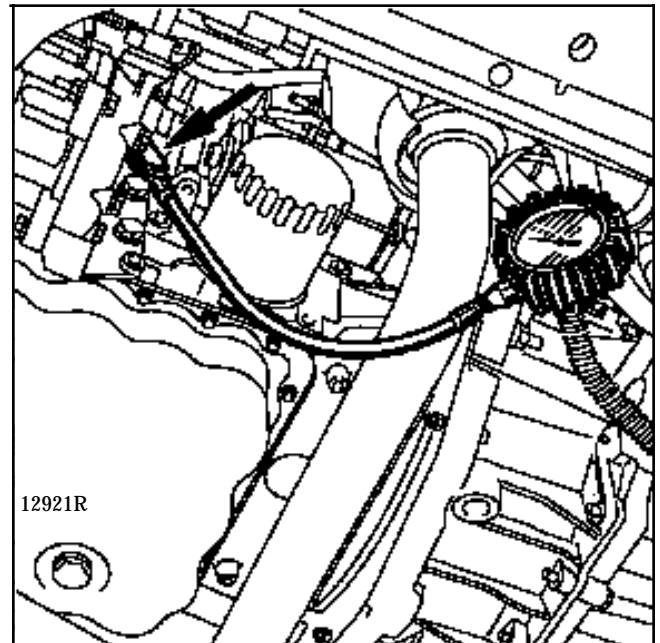

SPECIAL TOOLING REQUIRED		
Mot.	1202	Hose clip pliers
Mot.	1282 -01	Spanner for removing high pressure union from the steering rack
Mot.	1289 -02	Fork for centring the suspended engine mounting limiter
Mot.	1390	Universal mounting
Mot.	1410	Tool for removing the A/C snap-fit unions
T. Av.	476	Ball joint extractor

TIGHTENING TORQUES (in daN.m)

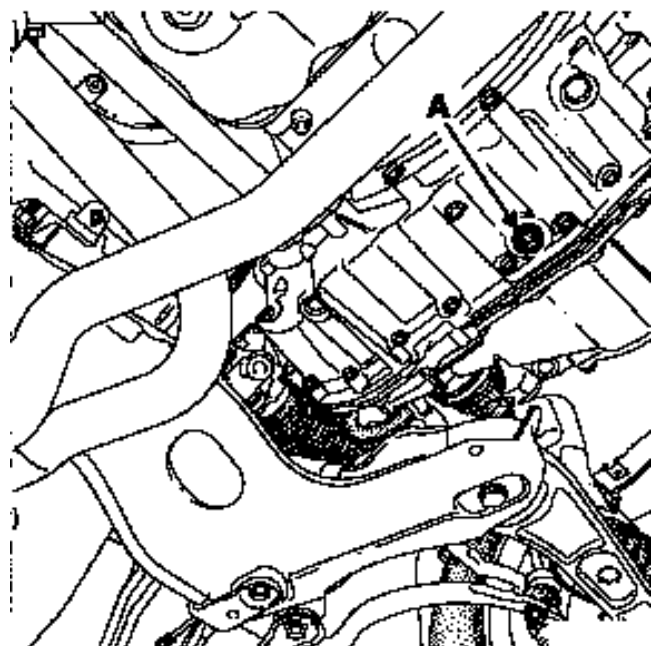
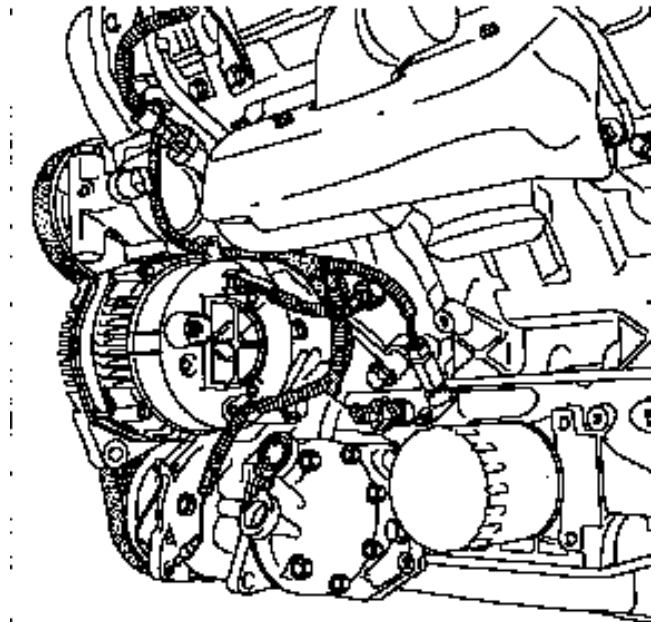

Drain the air conditioning circuit.

Remove the air conditioning pipe mountings on the right hand suspended engine mounting pad.

Disconnect:

- the main wiring loom for the engine connection unit,
- the air conditioning circuit unions (tool **Mot. 1410**); take care to block the pipes using plugs,
- the cooling assembly wiring loom.

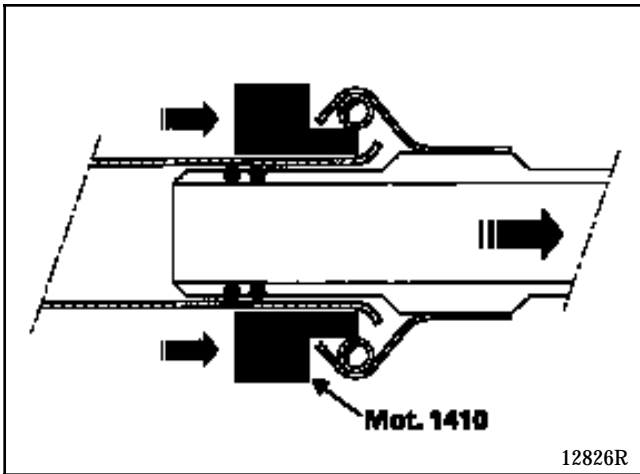

Remove:

- the front wheels,
- the right and left hand mud guards,
- the right and left hand driveshafts, (see **MR 315 SECTION 29** "Removal-Refitting the side driveshafts")
- the front bumper,
- the air filter assembly with air tube on the air unit,
- the pipe on the on the cruise control LDA,
- the brake servo vacuum pipe,
- the accelerator cable,

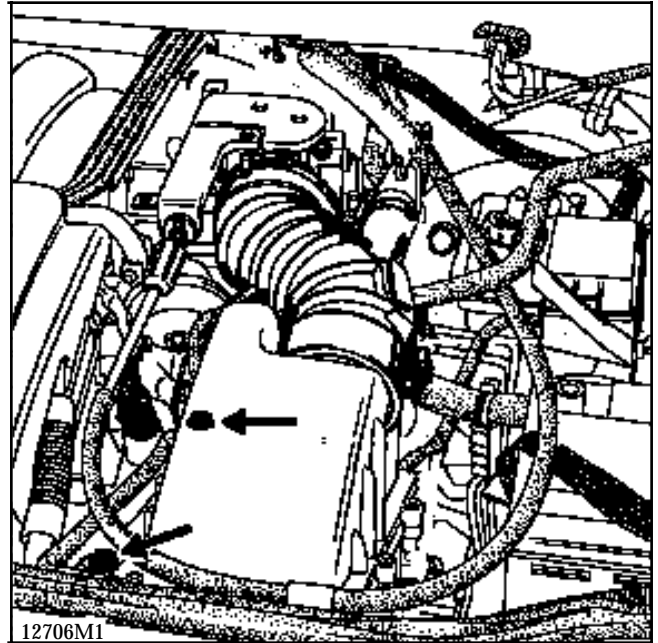

- the AT control.

IMPORTANT: the control rod at the end of the cable is very fragile; if it excessively twisted the complete control may have to be replaced.

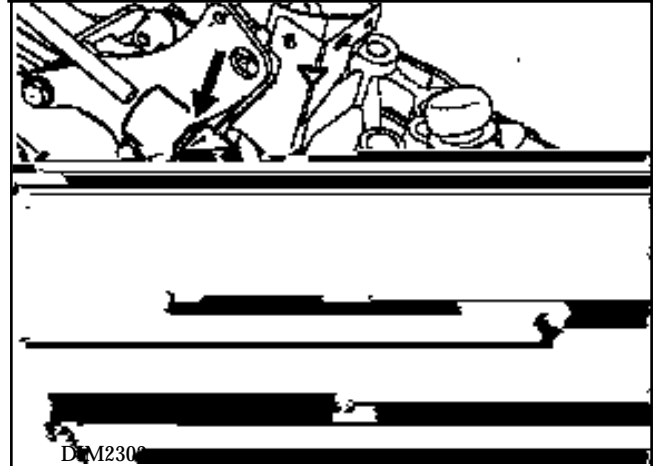

Engine - Gearbox

Remove:

- the upper radiator hose,
- the cooling assembly (see § 19 "cooling assembly")
- the heater matrix hoses where they join the engine,
- the expansion bottle hoses,
- the power assisted steering reservoir and move it to one side,
- the fuel supply and return pipes on the injector gallery by pressing on the closing clips at the end using a screwdriver then release them from the timing cover (5) and (6).

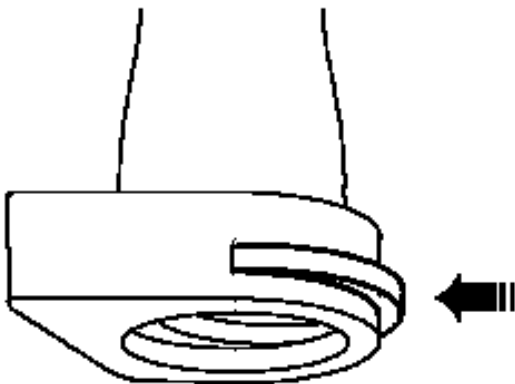
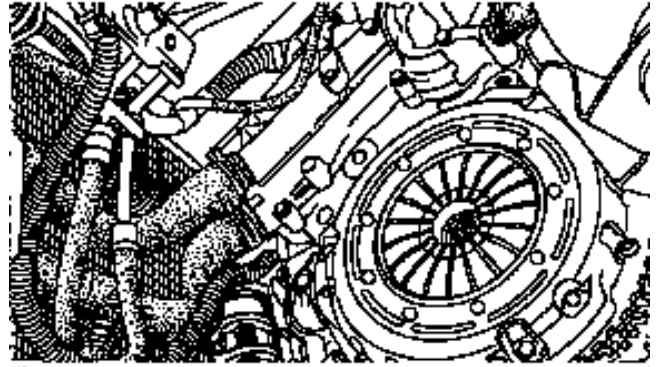
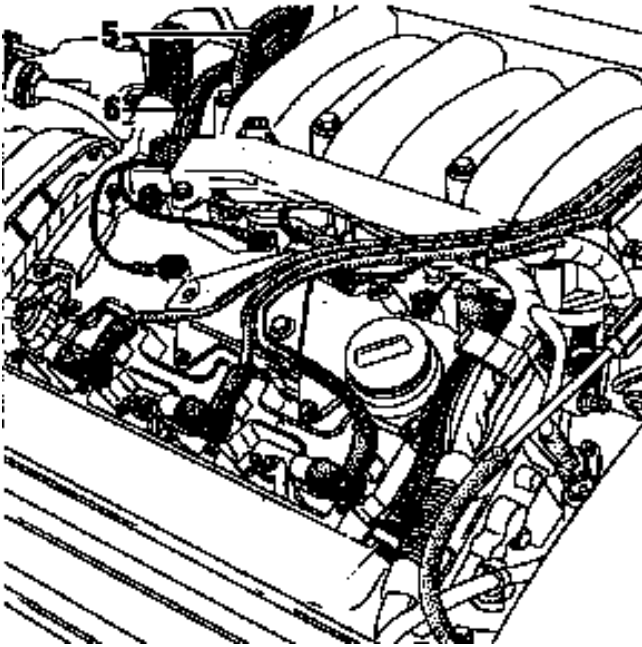

DIM1320

Engine - Gearbox

- the steering rack union (9) and power assisted steering exchanger (10), (Use tool **Dir. 1282-01** for union (9))

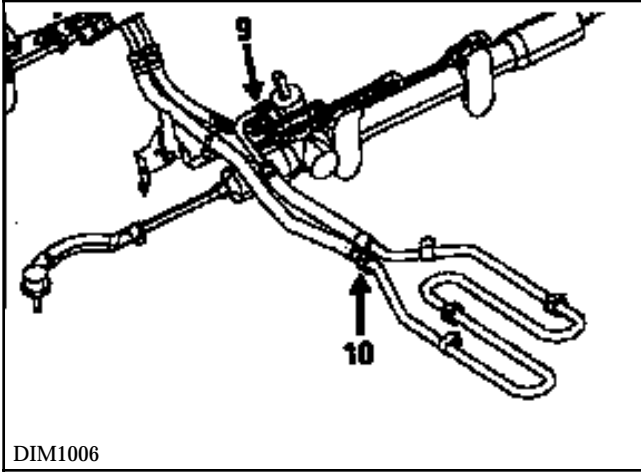

- bolt (7) and slacken engine tie bar bolt (8) .

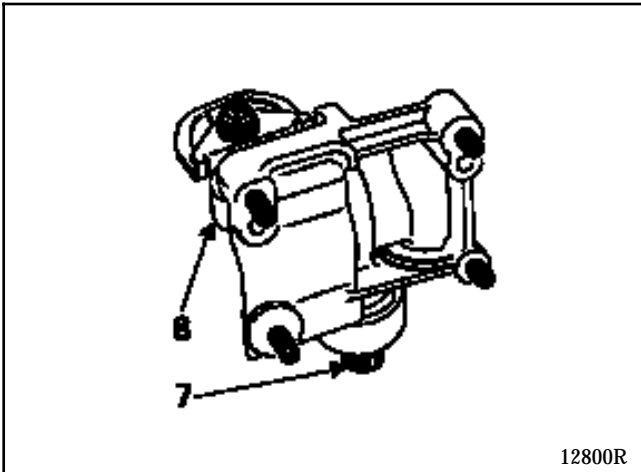

- Fit tool **Mot.1390** under the engine and transmission assembly
(Operation requires two people).

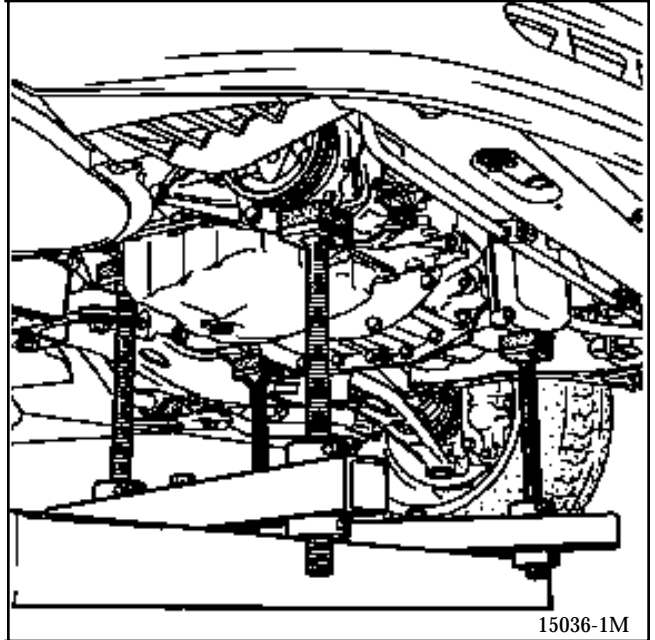

- Remove the suspended engine mounting cover.

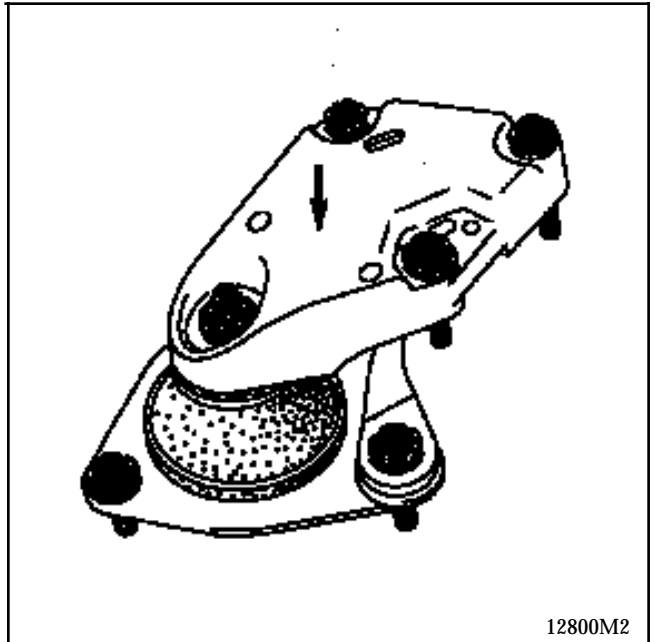

Remove:

- the gearbox mounting bolts, then, using a copper hammer, hit the stud to release it from the upper mounting pad,
- the mounting bolts and remove the suspended engine mounting.

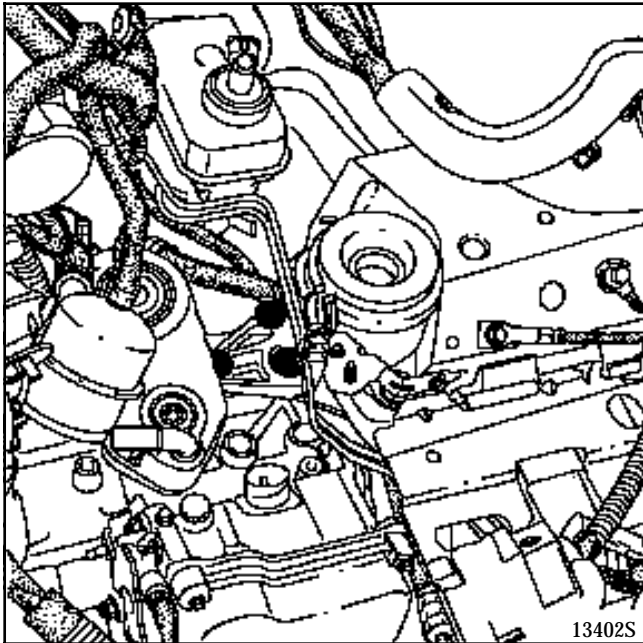

Raise the vehicle in relation to the engine and transmission assembly (operation requires two people).

When it is being lowered, push it slightly forwards to detach the rear bank of cylinders from contact with the sub-frame.

IMPORTANT: while lowering, progressively release the automatic transmission control from the cable sleeve stop to avoid breaking the control rod.

REFITTING - Special notes

Reposition the engine in its compartment, connecting the AT control as carefully as during removal.

Refit the suspended engine mountings. Refitting is the reverse of removal.

Observe the tightening torques.

ADJUSTING THE LONGITUDINAL MOVEMENT LIMITER

Slacken the movement limiter bolts (5).

Insert the limiter centring fork **Mot. 1289-02** into the apertures in the suspended engine mounting cover.

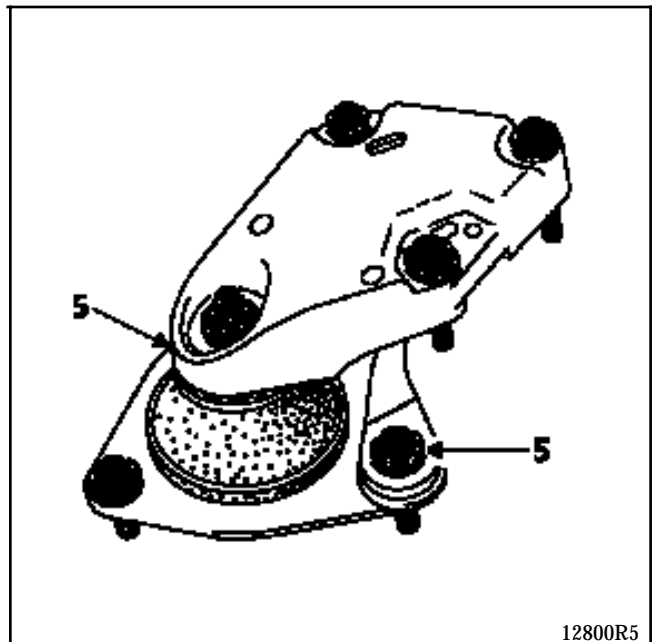

Tighten the limiter bolts (5) to a torque of **6.2 daN.m.**

Refitting is the reverse of removal.

Carry out the following operations:

- top up the gearbox oil level (see **Section 05 "Topping up the automatic transmission oil level"**),
- top up the engine oil level if necessary,
- fill and bleed the cooling circuit (see **Section 19 "Filling - Bleeding"**),
- fill and bleed the power assisted steering circuit,
- fill the air conditioning circuit (if equipped), with new R134a refrigerant, quantity: **890±25 grams**
- adjust the accelerator cable.

Fit the caliper mounting bolts using **Loctite FRENLOC** and tighten them to the recommended torque.

Press the brake pedal several times to bring the pistons into contact with the pads.

The removal and refitting of the sump does not present any major difficulties.

Tighten the bolts to a torque of **0.8 daN.m** in the following order:

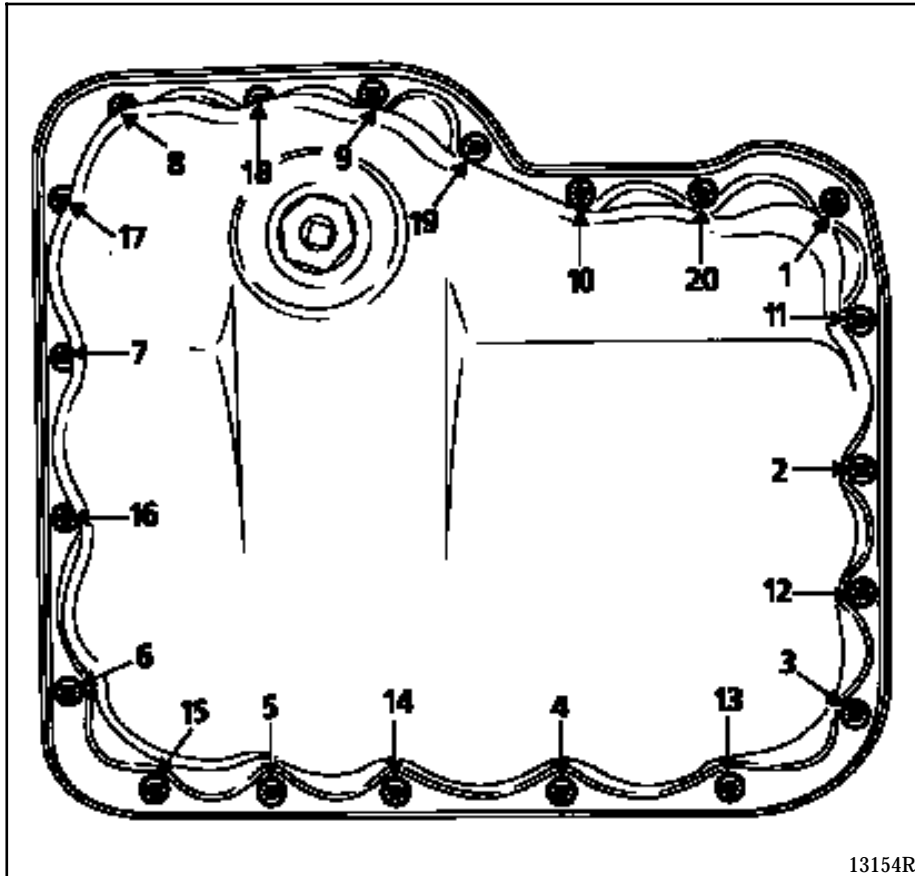

NOTE: the sealing of the sump is ensured by a composite seal which can endure several removal operations. If the seal is damaged, it can be partially repaired with the sealing product **AUTOJOINT OR**.

SPECIAL TOOLING REQUIRED		
Mot.	1273	Tool for checking belt tension
Mot.	1282 -01	Spanner for removing steering rack high pressure union
Mot.	1289 -02	Fork for centring the suspended engine mounting limiter
Mot.	1390	Engine support tool
Mot.	1428	Camshaft hub immobiliser
Mot	1429	Dynamic tensioner adjusting gauge
Mot	1410	Tool for removing/refitting refrigerant fluid unions
Mot.	1430	Camshaft and crankshaft sprocket timing pins
Mot.	1430 -01	Camshaft and crankshaft sprocket timing control pins
Mot.	1436	Timing belt retaining pin
Tav.	476	Ball joint extractor
EQUIPMENT REQUIRED		
Ball joint separator		

TIGHTENING TORQUES (in daN.m)	
Timing dynamic tensioner bolt	2.5
Camshaft sprocket bolts	1
Suspended engine mounting cover bolts	6.2
Wheel bolts	10

REMOVAL

Removal - refitting of the oil pump requires the engine and transmission assembly to be removed and refitted (see **Section 10 "Removal - refitting of the engine and transmission assembly"**)

Remove:

- the timing belt (see method described in **Section 11 - Timing belt**),
- the lower timing pulley,
- the crankshaft sprocket,
- the compressor mounting,
- the oil pump.

Oil pump

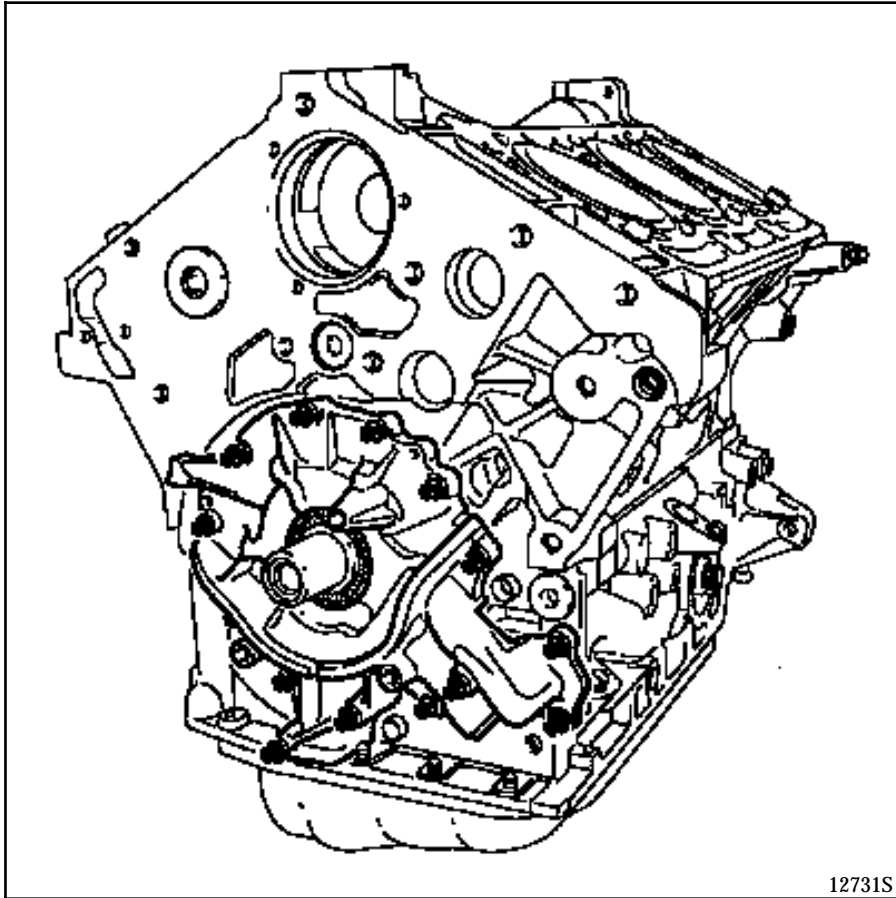

12731S

NOTE: the sealing of the oil pump is ensured by a composite seal which can endure several removal operations. If the seal is damaged, it can be partially repaired using the sealing product **AUTOJOINT OR.**

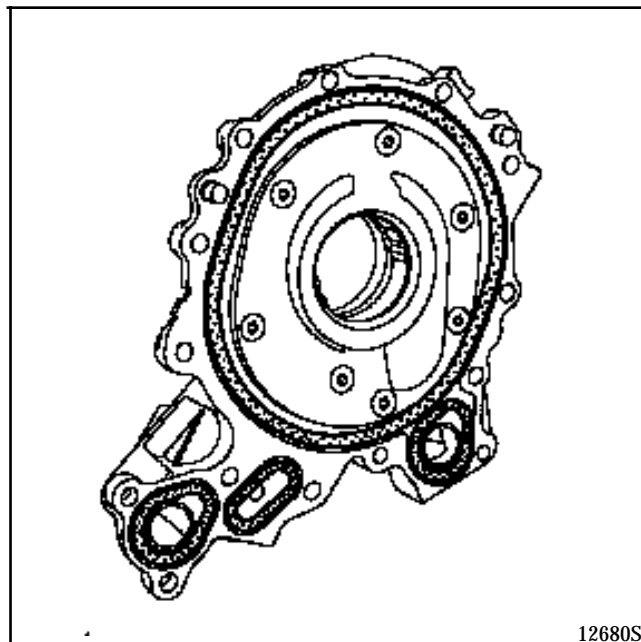

12680S

REFITTING

NOTE: to replace the oil pump, the body of the oil pump has to be filled with oil.

Fit the oil pump.

Hand tighten the bolts then tighten them to a torque of **0.8 daN.m** in the following order:

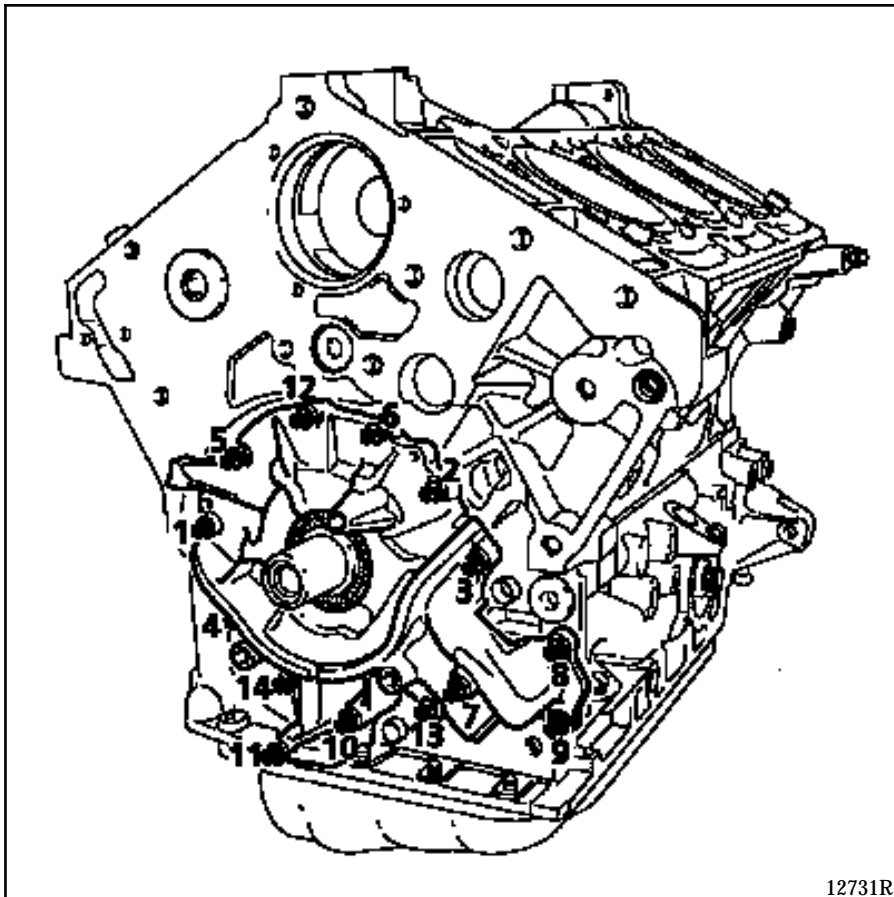

12731R

Refit the timing belt (see method described in **Section 11 - Timing belt**).

TOP AND FRONT OF ENGINE

Timing belt

11

SPECIAL TOOLING REQUIRED		
Mot.	1273	Tool for checking belt tension
Mot.	1282 -01	Spanner for removing steering rack high pressure union
Mot.	1289 -02	Centring fork for suspended engine mounting limiter
Mot.	1390	Engine support tool
Mot	1410	Tool for removal/refitting of refrigerant fluid unions
Mot.	1428	Camshaft hub immobiliser
Mot	1429	Dynamic tensioner adjusting gauge
Mot.	1430	Camshaft and crankshaft sprocket timing pins
Mot.	1430 -01	Camshaft and crankshaft sprocket timing control pins
Mot.	1436	Timing belt retaining pin
Tav.	476	Ball joint extractor
EQUIPMENT REQUIRED		
Ball joint separator		

TIGHTENING TORQUES (in daN.m)	
Timing dynamic tensioner bolt	2.5
Camshaft sprocket bolt	1
Suspended engine mounting cover bolt	6.2
Crankshaft pulley bolt	2.5
Wheel bolt	10

REMOVAL

Removal-refitting of the timing belt requires the engine and transmission assembly to be removed.

See method in **Section 10 "Removal/Refitting of the engine and transmission assembly"**.

Remove the engine style cover.

Remove the accessories bolt (see the method described in **Section 07 "Accessories belt tension"**).

TOP AND FRONT OF ENGINE

Timing belt

11

Remove:

- the accessories belt dynamic tensioner at (6),
- the power assisted steering pump pulley (7),
- the timing covers (A) and (B),
- the crankshaft pulley (8),
- the lower timing cover (C).

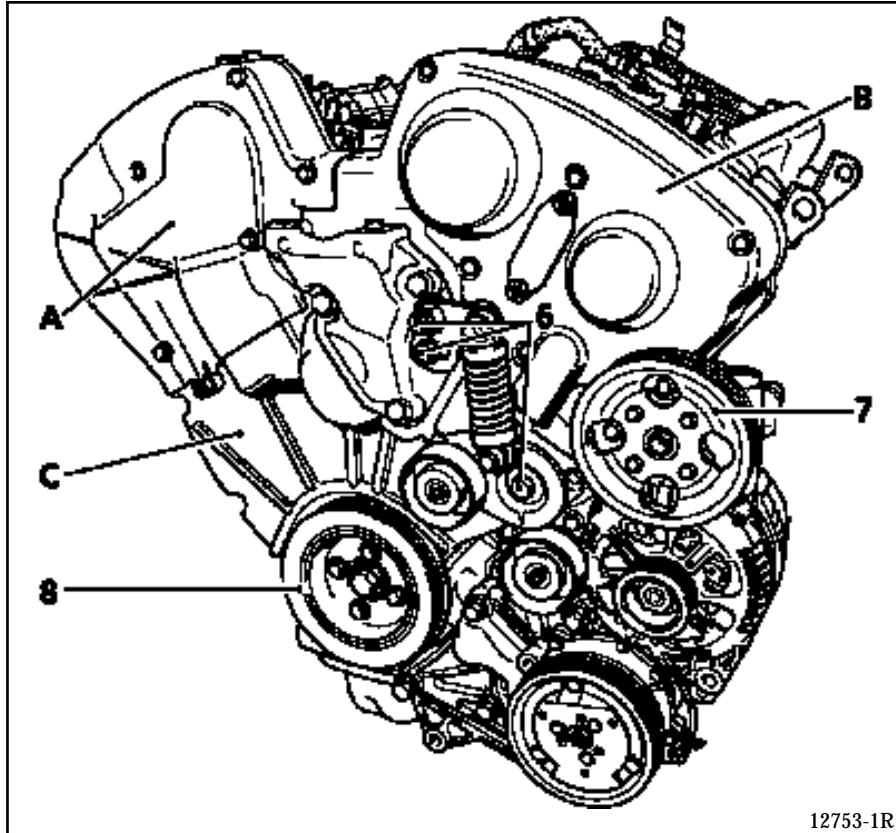

12753-1R

TOP AND FRONT OF ENGINE

Timing belt

11

- the sheet metal cover (9).

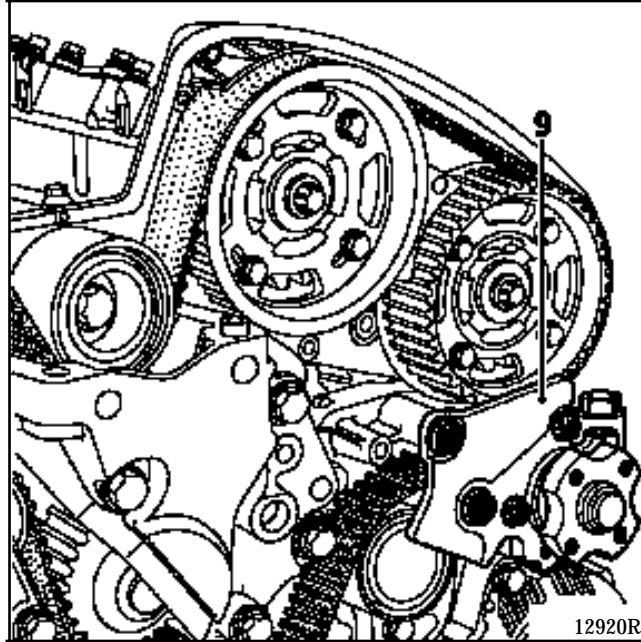

TOP AND FRONT OF ENGINE

Timing belt

Turn the engine in its operating direction in order to pin the crankshaft sprocket and camshafts using pins **Mot. 1430**.

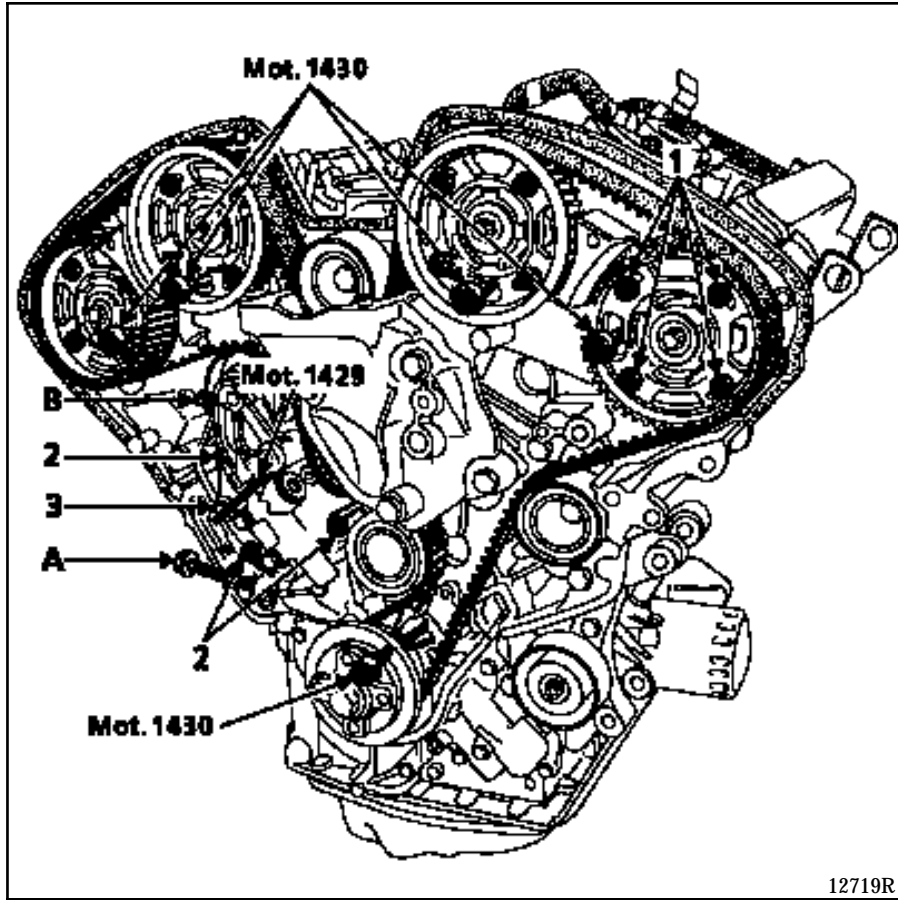

12719R

TOP AND FRONT OF ENGINE

Timing belt

11

In order to do this, slacken the camshaft sprocket bolts (1) and turn the camshaft hubs using tool **Mot. 1428**, in order to facilitate the fitting of the pins.

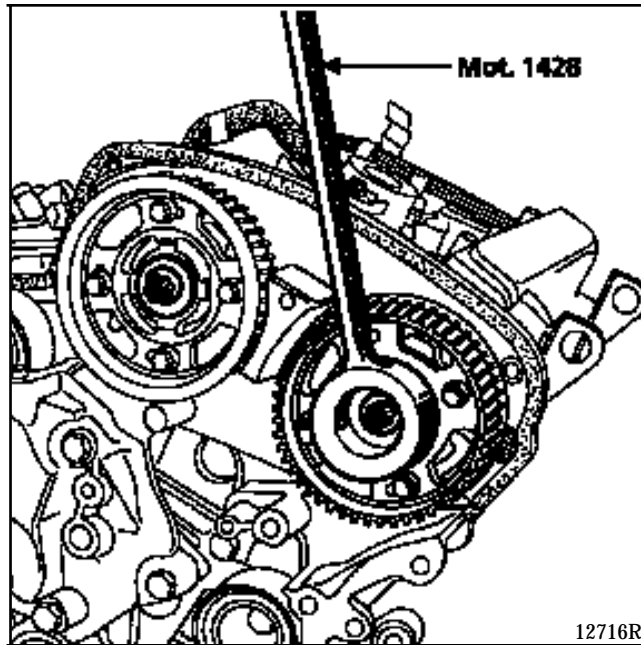

Fit a 75mm long M8 bolt (A) and tighten it as far as possible.

Slacken bolts (2).

Bolt (3) must remain locked.

Fit:

- tool **Mot. 1429** slackening bolt (A) if necessary,
- a **35mm** long M8 bolt (B) and tighten it until it comes into contact.

Tighten bolt (B) until tool **Mot. 1429** locks.

Slacken bolt (A), in order to loosen the timing belt.

Remove the timing belt.

TOP AND FRONT OF ENGINE

Timing belt

11

REMOVAL

Ensure the camshafts and the crankshaft are correctly pinned.

Tighten bolts (2) to a torque of **1 daN.m** then slacken them by 45°.

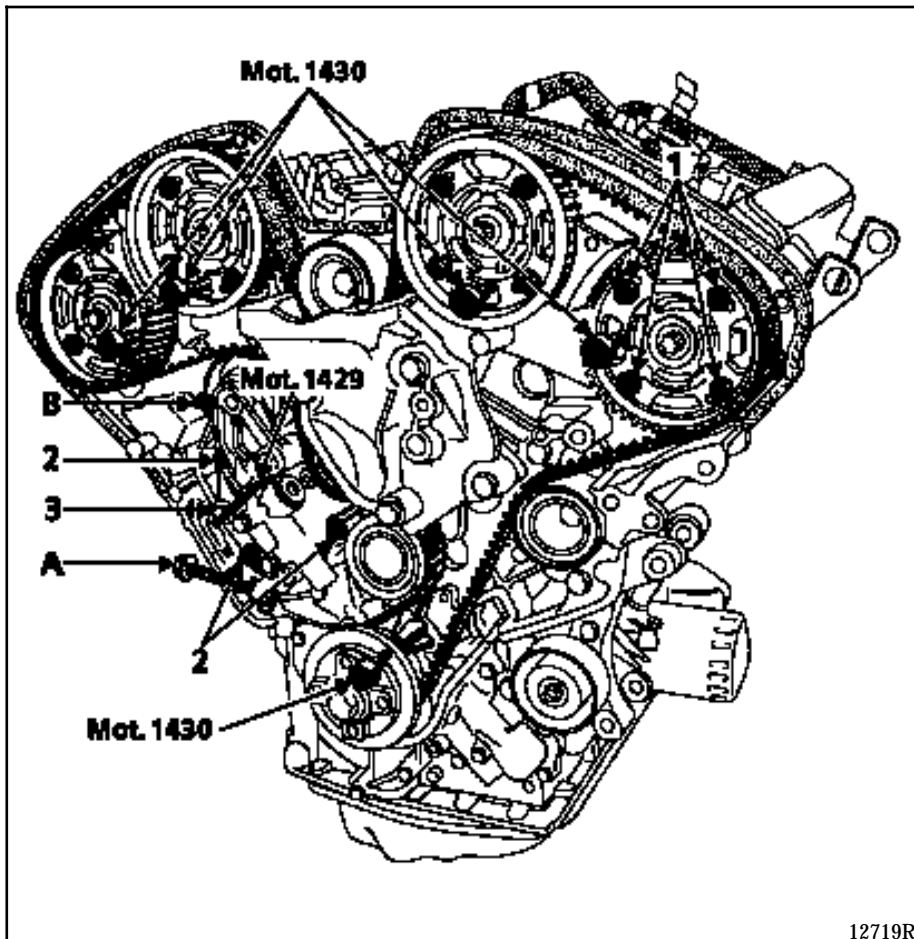

Turn the camshaft sprockets clockwise until they lock into the slots.

Tighten the bolts (1) to a torque of **0.5 daN.m** then slacken them by 45°.

TOP AND FRONT OF ENGINE

Timing belt

11

Fit the timing belt onto the crankshaft sprocket and immobilise it using tool **Mot. 1436**.

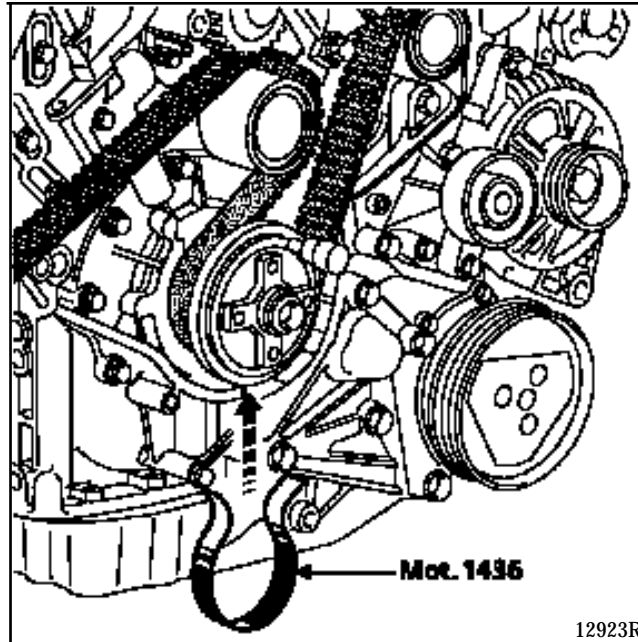

TOP AND FRONT OF ENGINE

Timing belt

11

Fit the belt onto the pulley (3) making sure that section (D) of the belt is properly tensioned.

Turn the camshaft sprocket (4) slightly anti-clockwise, in order to fit the belt onto the sprocket.

Carry out the same operations on sprockets (5), (6) and (7).

Fit the belt simultaneously onto the pulleys (8) and the sprocket (9).

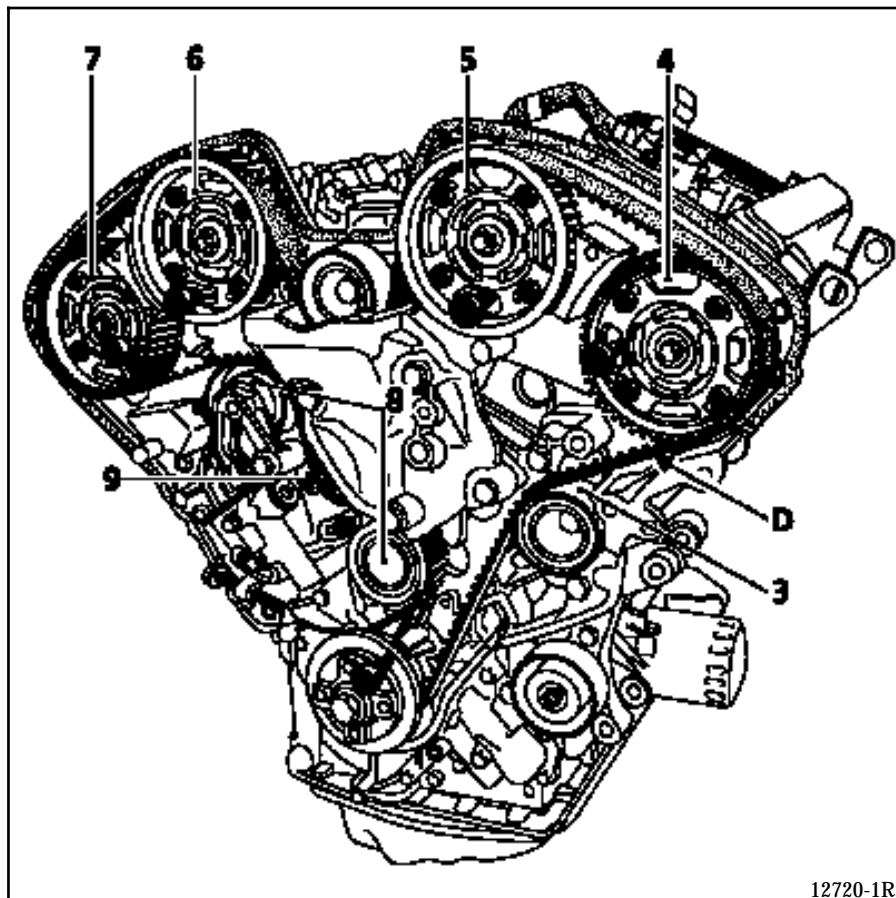

12720-1R

IMPORTANT :

- The angle of the movement of the sprocket in relation to the timing belt must not be greater than the value of one tooth.
- Check that the camshaft sprockets are not against the slot top: if they are, repeat the operation for fitting the timing belt.

TOP AND FRONT OF ENGINE

Timing belt

11

Remove tool **Mot. 1436** and fit the tool for checking the belt tension, **Mot. 1273**.

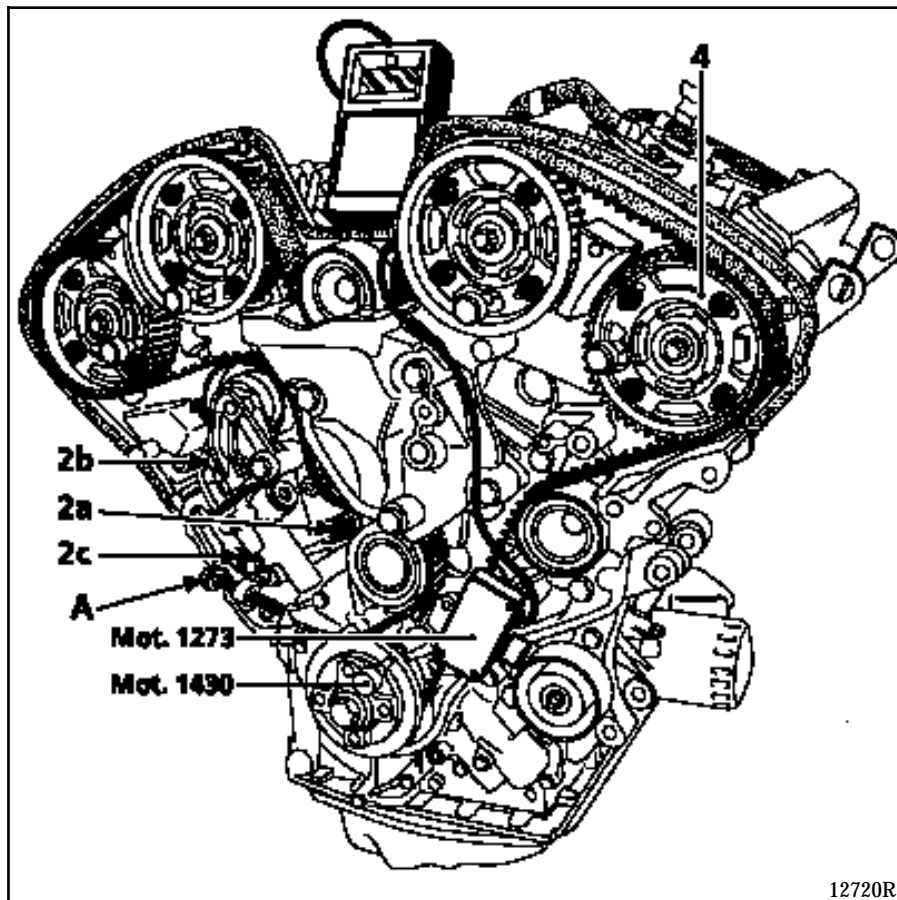

Tighten bolt (A) until you obtain a tension of **83±2 SEEM units**.

Tighten to a torque of **1 daN.m** bolts (2a) then (2b) and (2c).

Tighten the camshaft sprocket bolts to a torque of **1 daN.m** starting with camshaft (4).

Remove the camshaft and crankshaft timing pins.

Turn the engine over twice.

Pin the camshaft only using a pin, tool **Mot. 1430**.

Slacken bolts (2a), (2b) and (2c) by 45°.

TOP AND FRONT OF ENGINE

Timing belt

11

Remove bolt (B) and adjust bolt (A) to ensure tool **Mot. 1429** slides with no play.

Wait at least one minute (reaction time of the dynamic tensioner damper).

Check the sliding of tool **Mot. 1429**, then remove it.

Tighten to a torque of **2.5 daN.m** bolts (2a) then (2b) and (2c).

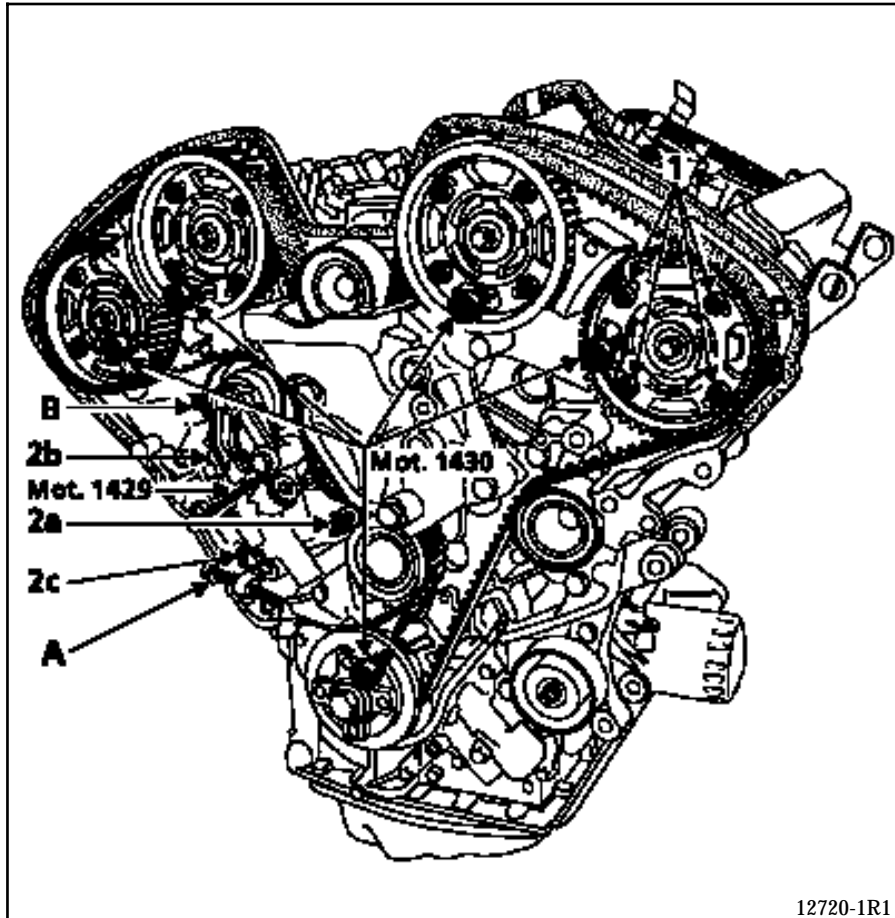

Remove bolt (A).

Tighten the bolts (1) of the camshaft sprockets to a torque of **1 daN.m**.

Remove the crankshaft timing pin.

TOP AND FRONT OF ENGINE

Timing belt

11

Turn the engine over twice in the operating direction.

Pin in the following order, using pins **Mot. 1430**:

- the crankshaft,
- the camshafts (4), (5), (6), and (7).

IMPORTANT:

- If pin **Mot. 1430** goes into its slot, slacken bolts (1) of the camshaft sprocket by 45°.
- If the pin **Mot. 1430** does not fit into its slot, the pinning operation of the camshafts is made easier by slackening bolts (1) by 45° and turning the camshaft hubs using tool **Mot. 1428**.

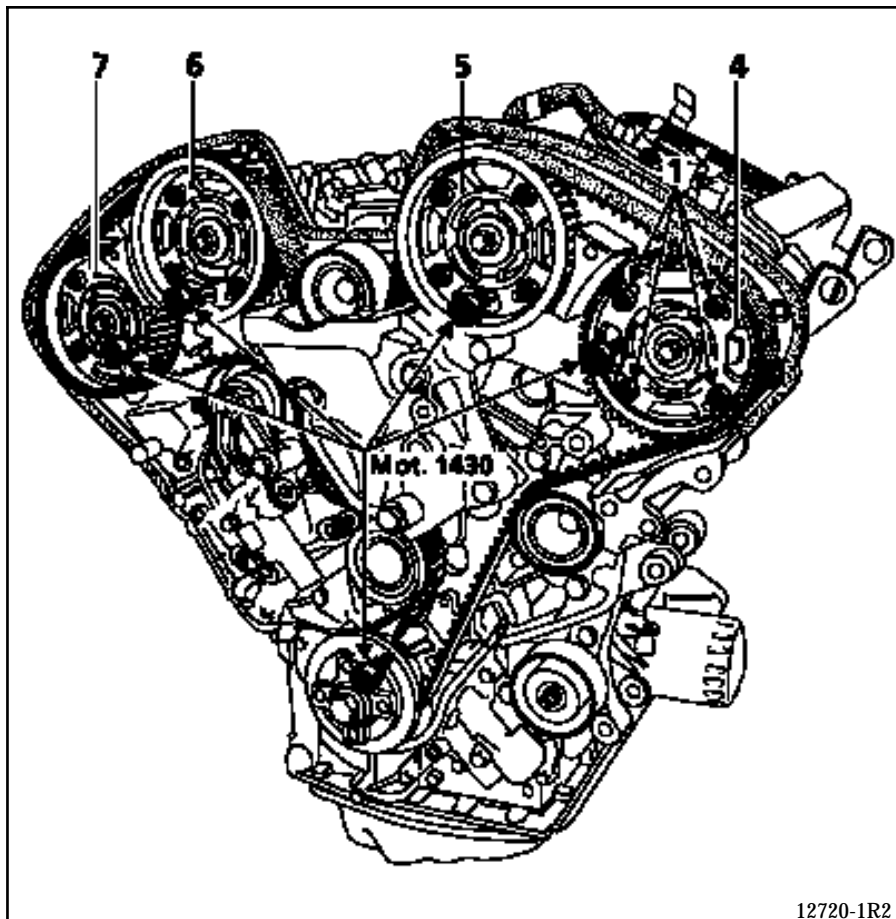

Tighten bolts (1) to a torque of **1 daN.m** starting from sprocket (4), then (5), (6) and (7).

Remove the pins **Mot. 1430** from the camshafts and the crankshaft.

TOP AND FRONT OF ENGINE

Timing belt

11

CHECKING THE TIMING

Turn the engine over twice.

Fit the crankshaft timing pin **Mot. 1430**.

Check that the timing pin **Mot. 1430-01** fits easily in the cylinder head pin holes until it touches the camshaft sprockets.

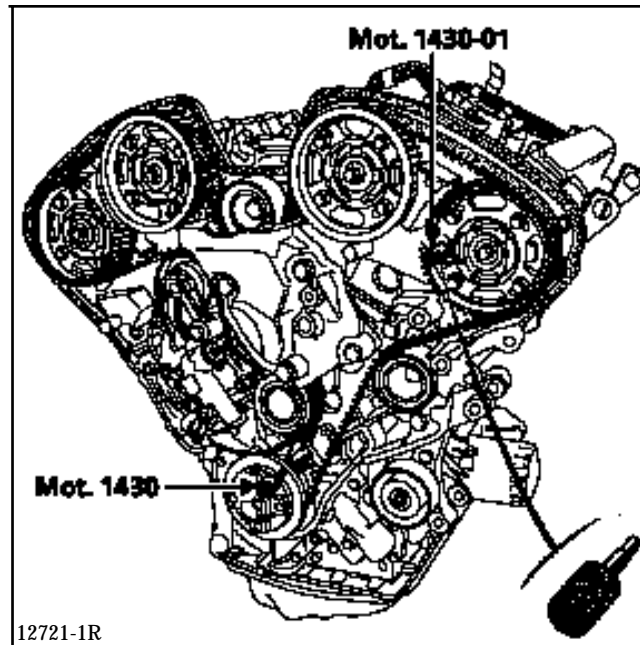

If they do not, repeat the refitting of the timing belt.

Remove the crankshaft timing pin.

Refitting is the reverse of removal.

Adjust the movement limiter using **Mot. 1289-02** (see procedure in Section 10).

Refit the accessories belt (see Section 07 "Accessories belt tension").

TOP AND FRONT OF ENGINE

Cylinder head

11

The removal of the cylinder head requires the removal - refitting of the engine and transmission assembly.

See **Section 10 "Removal - refitting of the engine and transmission assembly"**.

See **NT 2805** and the "**L7X engine**" section for removal and refitting of the cylinder head gaskets, camshafts and the rotating seals.

FUEL MIXTURE Specifications

12

Vehicle	Gearbox	Engine							Depollution standard
		Type	Suffix	Bore (mm)	Stroke (mm)	Capacity (cm ³)	Ratio	Catalytic converter	
JE0 G	LM0	L7X	727	87	82.6	2 946	10.5/1	◇ C 100	EU 96

Engine		Tests carried out at idle speed *					Fuel *** (minimum octane rating)
Type	Suffix	Engine speed (rpm)	Emission of pollutants **				
			CO (%) (1)	CO ₂ (%)	HC (ppm)	Oxygen (λ)	
L7X	727	650±50	0.5 max	14.5 min	100 max	0.97<λ<1.03	Unleaded (OR 95)

(1) at **2500 rpm**, the CO should be **0.3** maximum.

* For a coolant temperature greater than **80°C** and after the engine speed stabilises at **2500 rpm** for approximately **30 seconds**. Tests to be carried out after returning to idle speed.

** For legislative values, refer to specification for individual country.

*** Compatible OR 91 unleaded.

Temperature in °C (± 1°)	0	20	40	80	90
Air temperature sensor Type CTN Resistance in Ohms	5500 to 6500	2000 to 3000	1000 to 1500	-	-
Coolant temperature sensor Type CTN (2 track green connector) Resistance in Ohms	5500 to 6500	2000 to 3000	1000 to 1500	270 to 350	220 to 250

FUEL MIXTURE Specifications

12

ALLOCATION	MAKE/TYPE	SPECIAL NOTES															
Computer	BOSCH/MP7.0	55 tracks															
Injection		Semi-sequential regulated multipoint															
Ignition		Static with three monoblock dual output coils Power module integrated in computer One pinking sensor Tightening torque 2 daN.m Firing order : 1 - 6 - 3 - 5 - 2 - 4 <table border="1" style="margin: 10px auto; border-collapse: collapse;"> <thead> <tr> <th style="width: 50%;">Tracks</th> <th style="width: 50%;">Resistance (Ω)</th> </tr> </thead> <tbody> <tr> <td>1-2 3-4 1-4 1-3 2-3 2-4</td> <td style="text-align: center;">1.1</td> </tr> <tr> <td>HT cylinders</td> <td style="text-align: center;">12.5</td> </tr> </tbody> </table>	Tracks	Resistance (Ω)	1-2 3-4 1-4 1-3 2-3 2-4	1.1	HT cylinders	12.5									
Tracks	Resistance (Ω)																
1-2 3-4 1-4 1-3 2-3 2-4	1.1																
HT cylinders	12.5																
TDC sensor		Resistance on tracks 1-2: 375 Ω															
Plugs	NGK PFR 6 E - 10	Gap: 1.0 mm (adjustable) Tightening torque: 3 daN.m															
Fuel filter		Mounted in front of the fuel tank under the vehicle . Replace at major service															
Fuel supply pump	WALBRO	Submerged in the fuel tank Flow: 80 l/h minimum at regulated pressure of 3 bars and a voltage of 12 volts															
Pressure regulator	BOSCH	Regulated pressure Zero vacuum: 3 ± 0.2 bars Vacuum of 500 mbars: 2.5 ± 0.2 bars															
Pulse damper	BOSCH																
Solenoid injector	BOSCH	Voltage: 12 Volts Resistance : 13±1 Ω															
Throttle body	SOLEX	Mark 646															
Throttle potentiometer	BOSCH	Voltage: 5 Volts <table border="1" style="margin: 10px auto; border-collapse: collapse;"> <thead> <tr> <th colspan="3" style="text-align: center;">Resistance</th> </tr> <tr> <th style="width: 33%;">Track</th> <th style="width: 33%;">No load (Ω)</th> <th style="width: 33%;">Full load (Ω)</th> </tr> </thead> <tbody> <tr> <td>1-2</td> <td style="text-align: center;">1930</td> <td style="text-align: center;">1930</td> </tr> <tr> <td>1-3</td> <td style="text-align: center;">1130</td> <td style="text-align: center;">2680</td> </tr> <tr> <td>2-3</td> <td style="text-align: center;">2515</td> <td style="text-align: center;">970</td> </tr> </tbody> </table>	Resistance			Track	No load (Ω)	Full load (Ω)	1-2	1930	1930	1-3	1130	2680	2-3	2515	970
Resistance																	
Track	No load (Ω)	Full load (Ω)															
1-2	1930	1930															
1-3	1130	2680															
2-3	2515	970															

FUEL MIXTURE Specifications

12

ALLOCATION	MAKE/TYPE	SPECIAL NOTES
Idle speed regulation solenoid valve	BOSCH	Voltage: 12 Volts Resistance tracks 1-3: 24 Ω 1-2 : 12 Ω 2-3 : 12 Ω
Fuel vapour rebreathing canister Solenoid valve	-	Voltage: 12 volts (RCO control) Resistance: 30±5 Ω
Heated oxygen sensor	77 00 105 557 suffix B BOSCH LSW 24 WS	Voltage at 850°C Rich mixture > 625 mvolts Lean mixture: 0 to 80 mvolts Heating resistance, track 1-2 : 2 to 15 Ω Tightening torque: 4 to 5 daN.m
Fault finding (defined in the specific Technical Note)	FICHE n° 47 CODE D13 SELECTOR S8	Throttle potentiometer: Idle regulation $0 \leq \#08 \leq 1000$ Full load $\#17 \geq 77$ R.C.O.idle speed $20 \leq \#12 \leq 40$ Adaptive R.C.O.idle speed $-12.5 \leq \#21 \leq +12.5$ Adaptive richness operation $0.75 \leq \#30 \leq 1.25$ Adaptive richness idle speed $-1 \leq \#31 \leq 1$

TIGHTENING TORQUES (in daN.m)



Throttle body mounting bolt on inlet manifold

2

REMOVAL

Disconnect:

- the battery,
- the accelerator cable,
- the ball joint (1) of the cruise control rod,
- the throttle potentiometer connector (3).

Remove:

- the air filter unit,
- the accelerator cable sleeve stop (2),
- the air intake pipe (disconnect the oil vapour rebreathing pipe and the air intake from the idle speed regulation solenoid valve),
- the fuel vapour rebreathing pipe (5),
- the oil vapour rebreathing pipe (4) (use tool **Mot. 1311-06**)

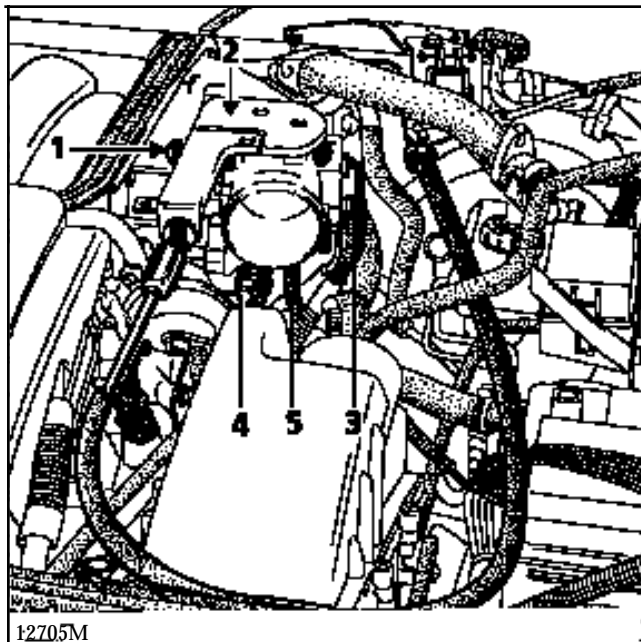
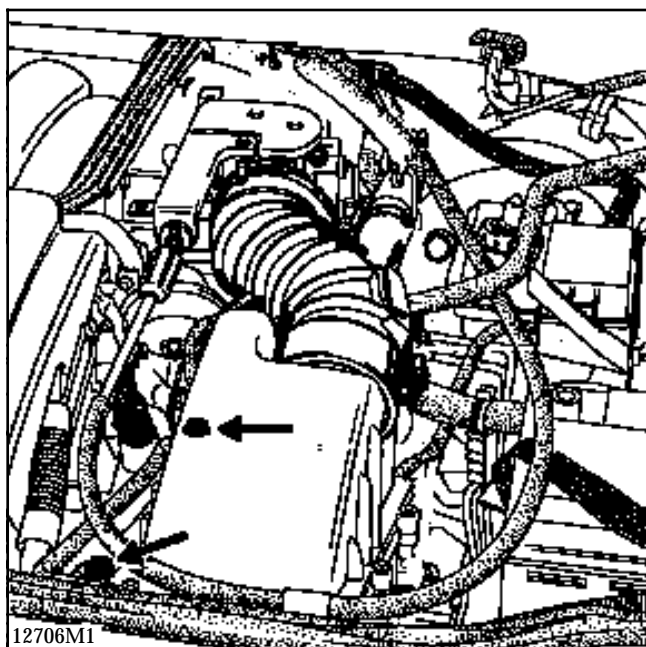

Remove the throttle body mounting bolts then remove the throttle body.

NOTE: the throttle position potentiometer cannot be adjusted.

REFITTING

Replace the paper seal.

Refitting is the reverse of removal.

TIGHTENING TORQUES (in daN.m)	
Manifold mounting bolt	2
Distributor mounting	2,5

REMOVAL OF THE INLET MANIFOLD

To remove and refit the inlet manifold, the engine and transmission assembly has to be lowered by approximately **5 cm** to allow access to the rear mountings.

Place the vehicle on a two post lift.

Disconnect the battery.

Remove the engine cover.

Place a piece of cardboard in front of the radiator to protect it.

Disconnect:

- the high voltage coil wires,
- the 3 earth wires (2),
- the oil vapour rebreathing pipe (3) (use tool **Mot. 1311-06**),
- the injector electric connectors,
- the pipe connected to the fuel pressure regulator,
- the fuel supply and return pipes (5) and (6).

Remove:

- the wiring support mounting bolts (7), then tilt it forward,

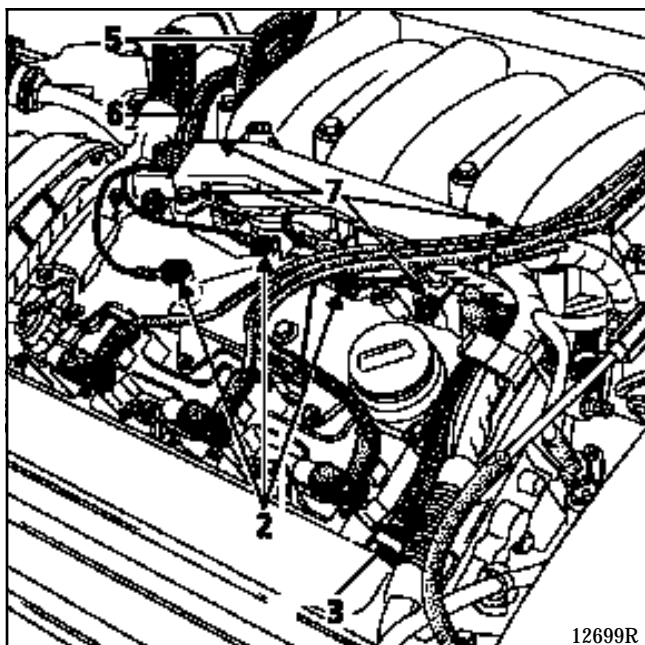

- the air filter unit with its hose connecting it to the throttle body (two bolts between the cylinder head and the throttle body, plus a fitting from below).
- the accelerator cable sleeve stop (11), after disconnecting the throttle body control.

Disconnect:

- the regulator control ball joint (12),
- the oil vapour rebreathing pipe (8), (use tool **Mot. 1311-06**),
- the fuel vapour rebreathing pipe (9),
- the potentiometer connector (10).

Remove a wiring support clip under the potentiometer connector (10)

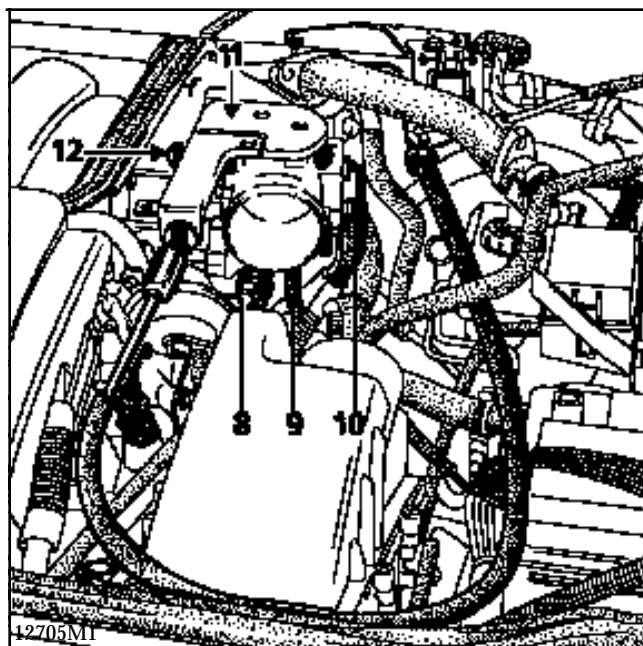

Completely remove the engine tie bar.

Set the engine and transmission assembly on the engine support tool **Mot. 1390** (operation requires two people).

Slacken the two gearbox suspended mounting pads (13) and remove the engine and transmission assembly mounting nut (14) on the body.

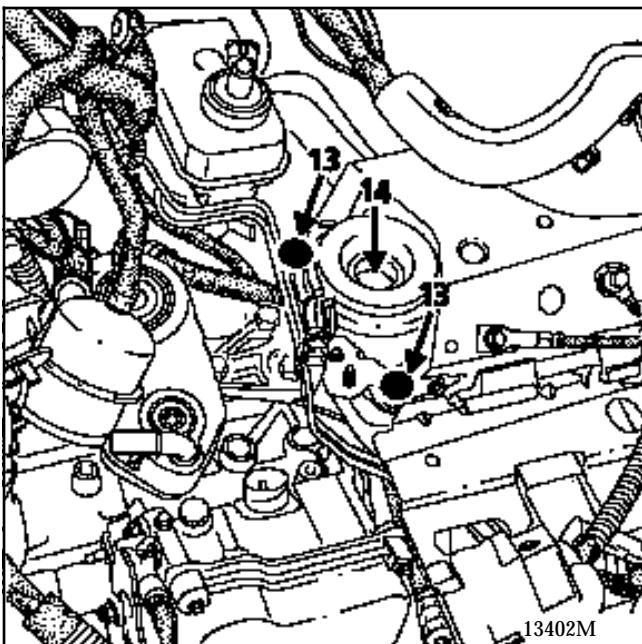
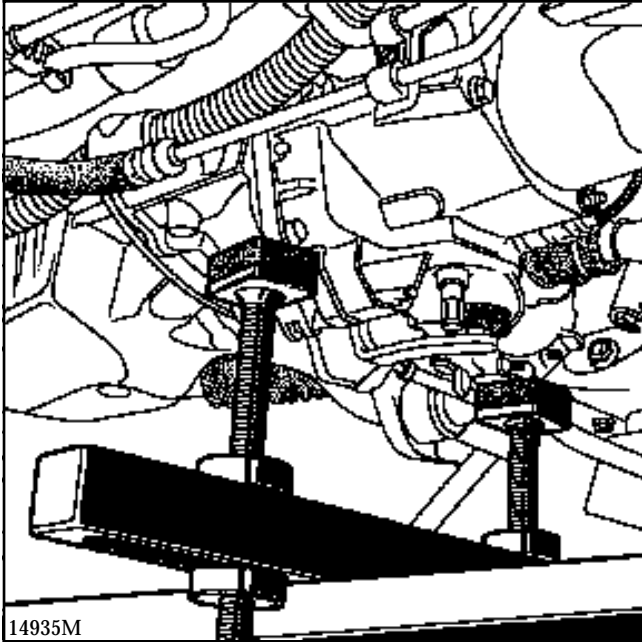

Remove the right hand suspended engine mounting cover.

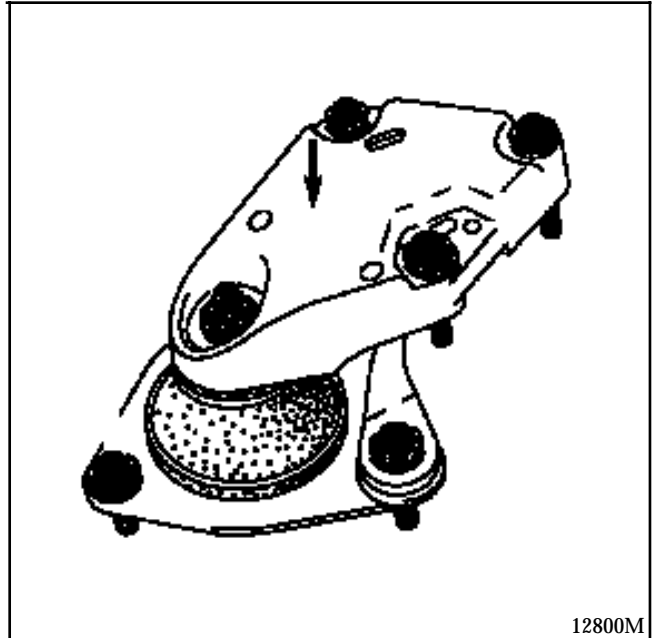

Unclip the power assisted steering oil return pipe from the radiator clips.

Lower the engine by **5 cm** in relation to the vehicle.

IMPORTANT: the amount by which it can be lowered is restricted by the right hand driveshaft rubber gaiter and the sub-frame.

Disconnect the pressure sensor (15) and the idle speed solenoid valve connector (16).

Remove bolts (17), (18) and (19) securing the manifold to the lifting brackets.

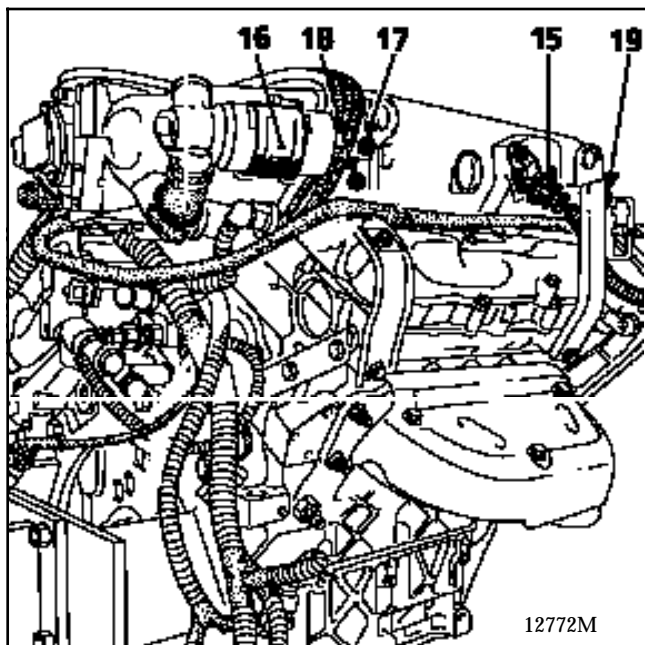

NOTE : bolt (17) and (19): 10 mm spanner
bolt (18): 13 mm spanner

Remove the seven front mounting bolts securing the inlet manifold then extract it.

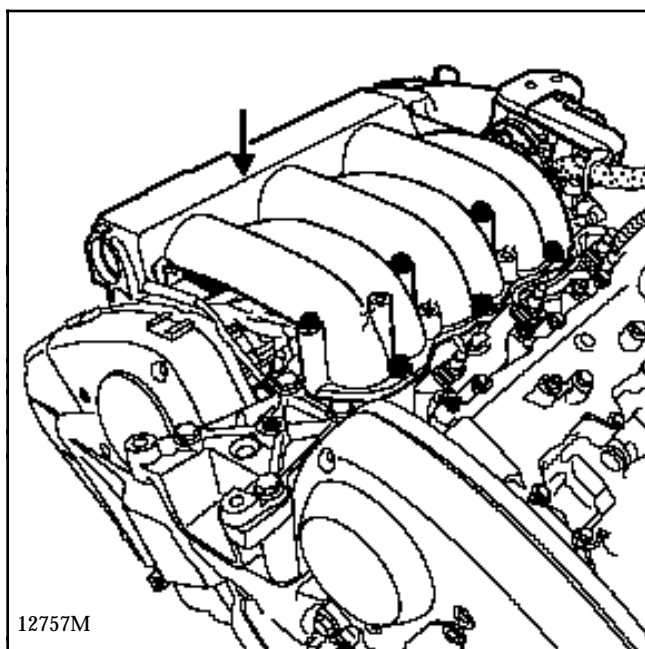

REMOVING THE INLET DISTRIBUTOR

Disconnect the electric connectors (28) from the rear injectors.

Remove the two bolts (29) on the rear cylinder head cover securing the vehicle wiring harness.

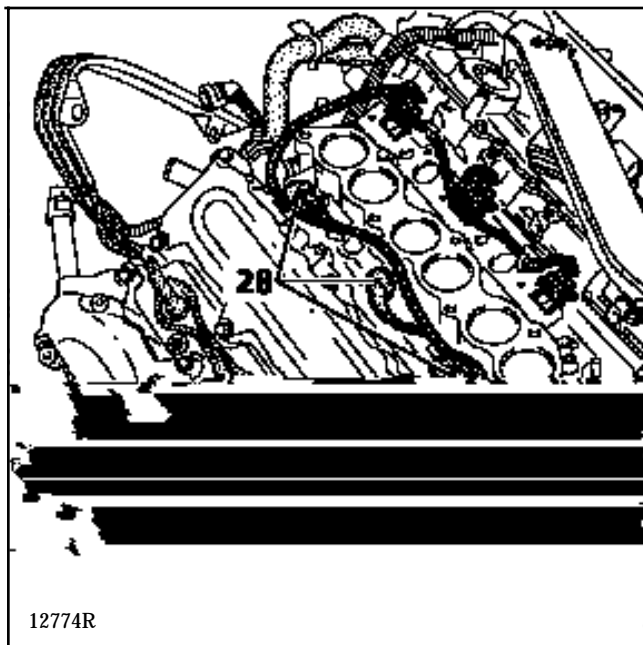

Remove the inlet distributor mounting bolts.

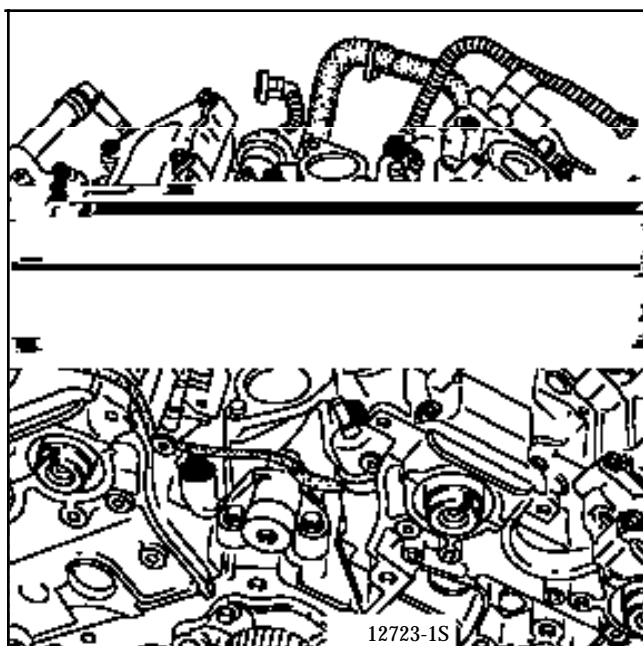

Remove the distributor and the injector galleries.

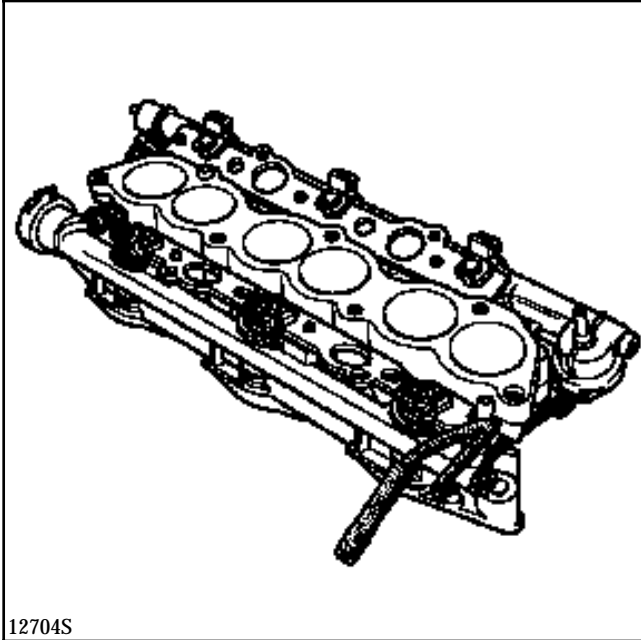

Remove the injector gallery.

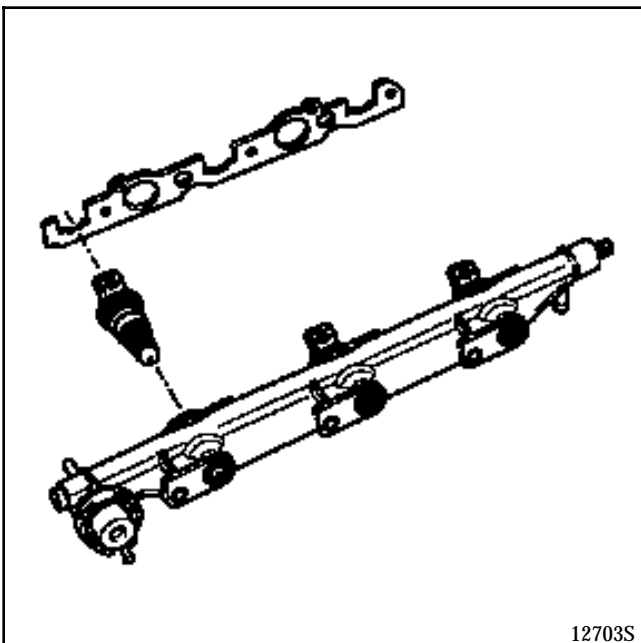

REFITTING

Replace the gaskets.

Refitting is the reverse of removal.

FUEL MIXTURE

Front exhaust manifold

12

TIGHTENING TORQUES (in daN.m)



Manifold nut

3

REMOVAL

Disconnect the battery.

Secure the exhaust to the vehicle body.

Remove the exhaust downpipe (1).

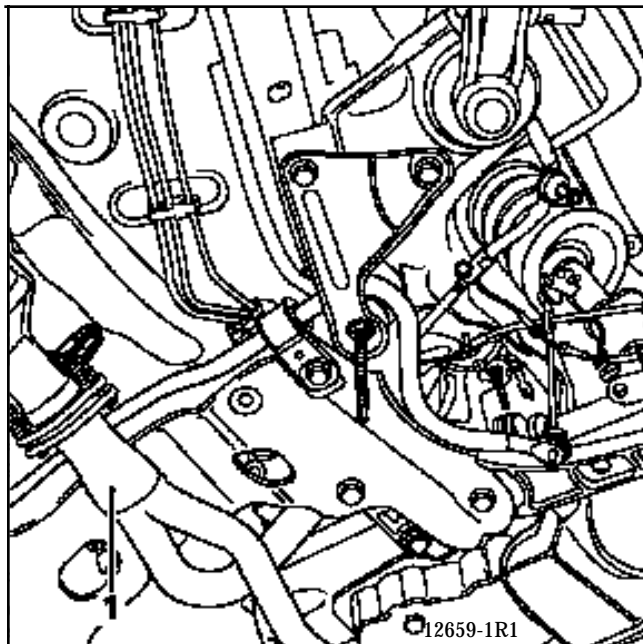
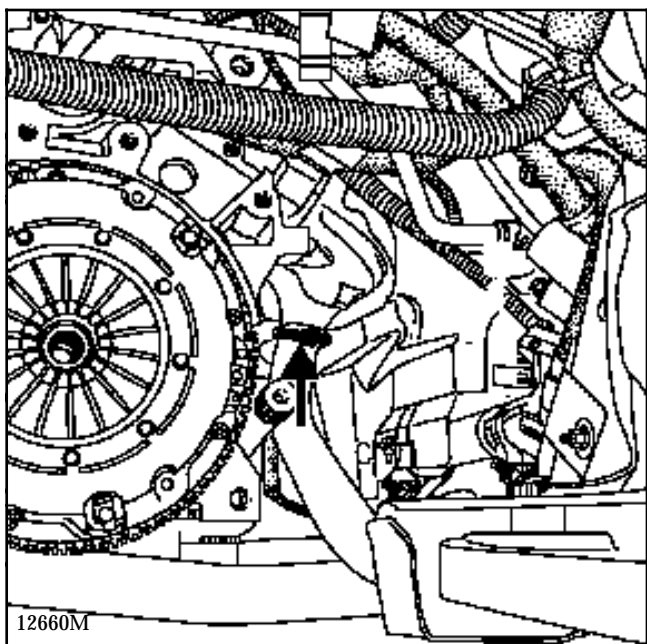
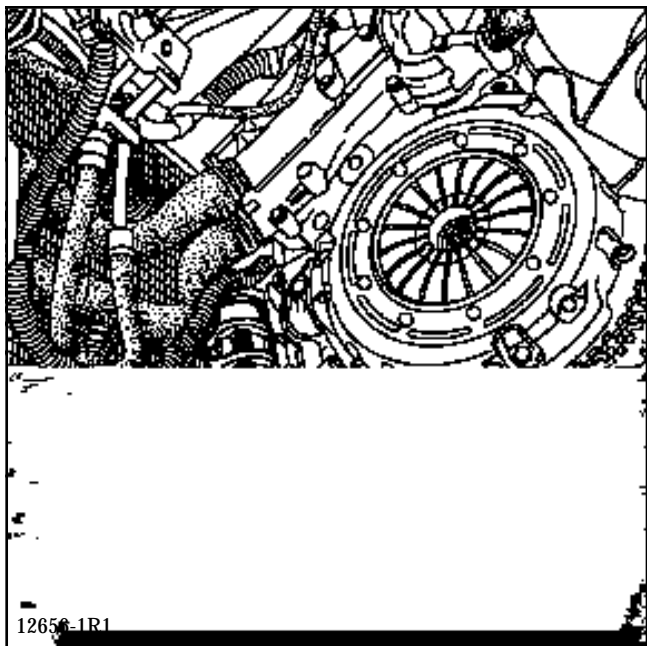

Remove:

- the starter motor heat shield (4).

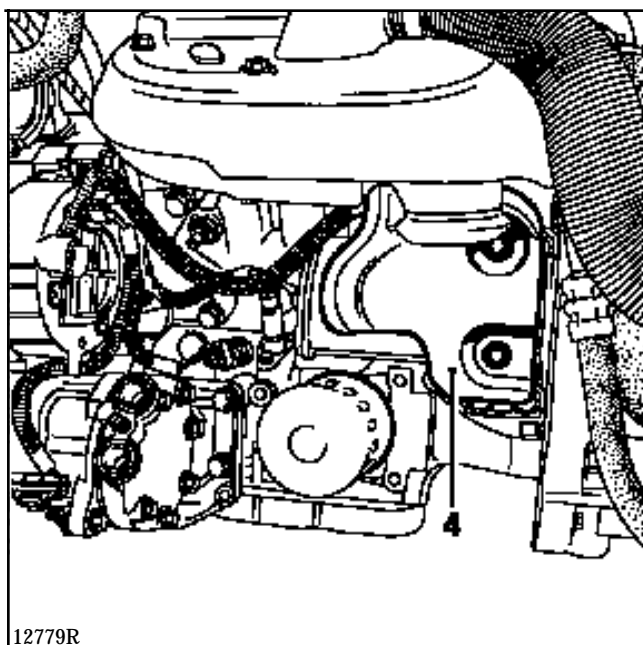

- the heat shield (3) under the exhaust manifold.

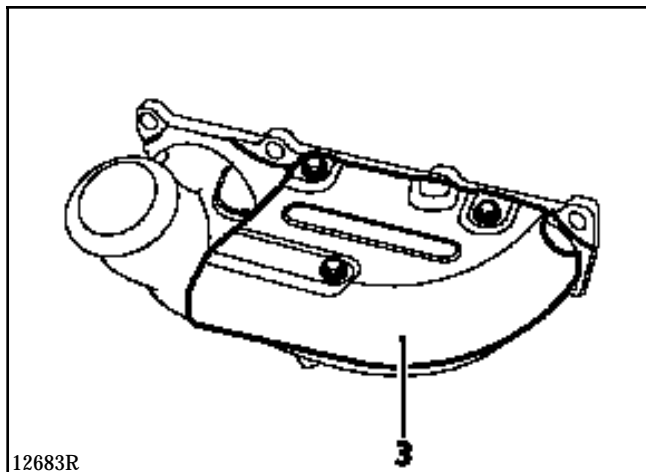

- the upper heat shield (5) from the exhaust manifold (6),

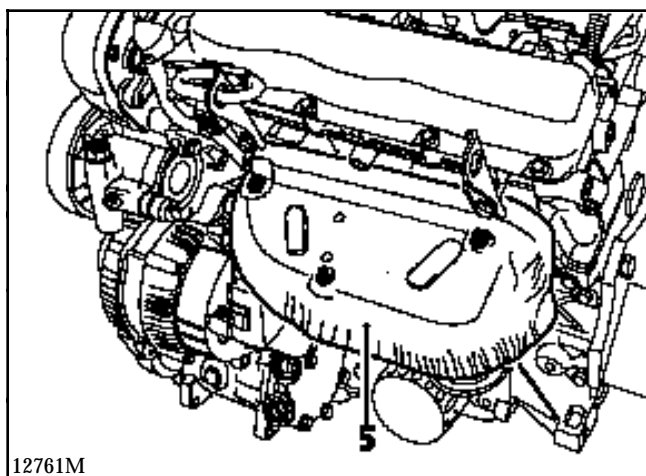

- the manifold mounting nuts (6) then extract it.

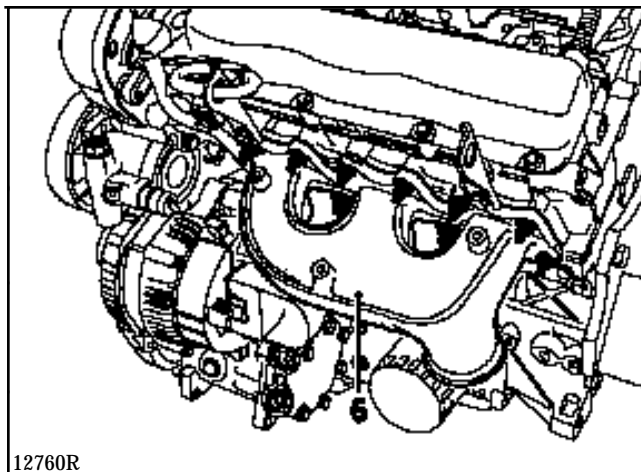

REFITTING

Replace the gasket.

Refitting is the reverse of removal.

FUEL MIXTURE

Rear exhaust manifold

12

TIGHTENING TORQUES (in daN.m)



Manifold nut

3

REMOVAL

Disconnect the battery.

Secure the exhaust to the vehicle body.

Remove the exhaust downpipe (1).

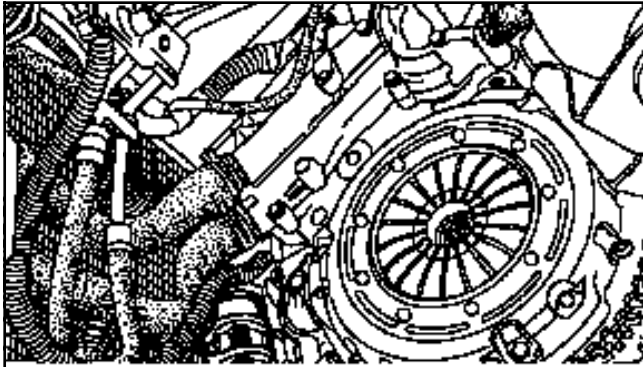

12657-1R1

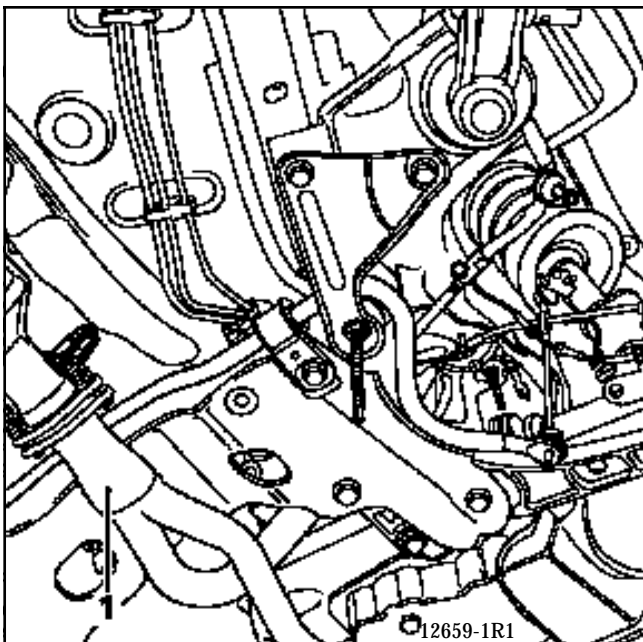

12659-1R1

Remove the engine tie bar and push the engine slightly forwards (be careful not to interfere with the cooling radiator). Insert a shim between the sub-frame and the gearbox.

Remove:

- the lower (3) and upper (2) manifold heat shields,

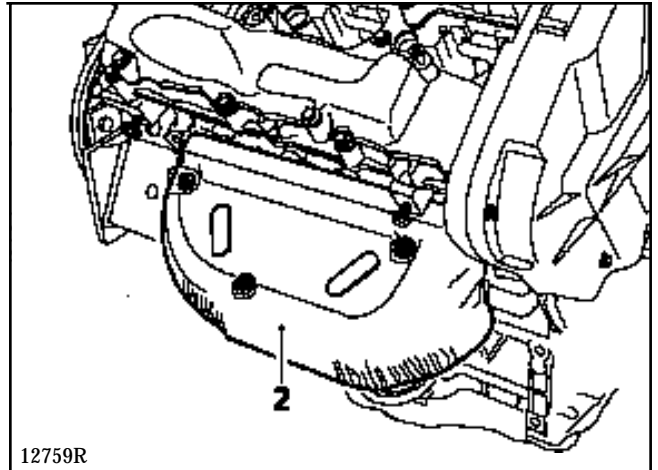

12759R

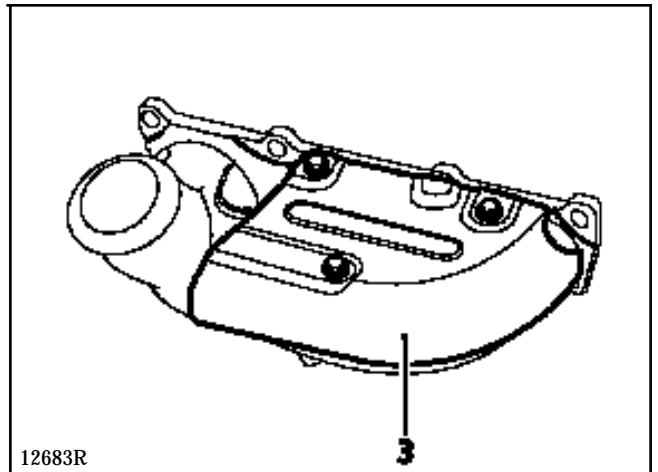

12683R

- the manifold mounting nuts, then extract it.

REFITTING

Replace the gasket.

Refitting is the reverse of removal.

INLET CIRCUIT

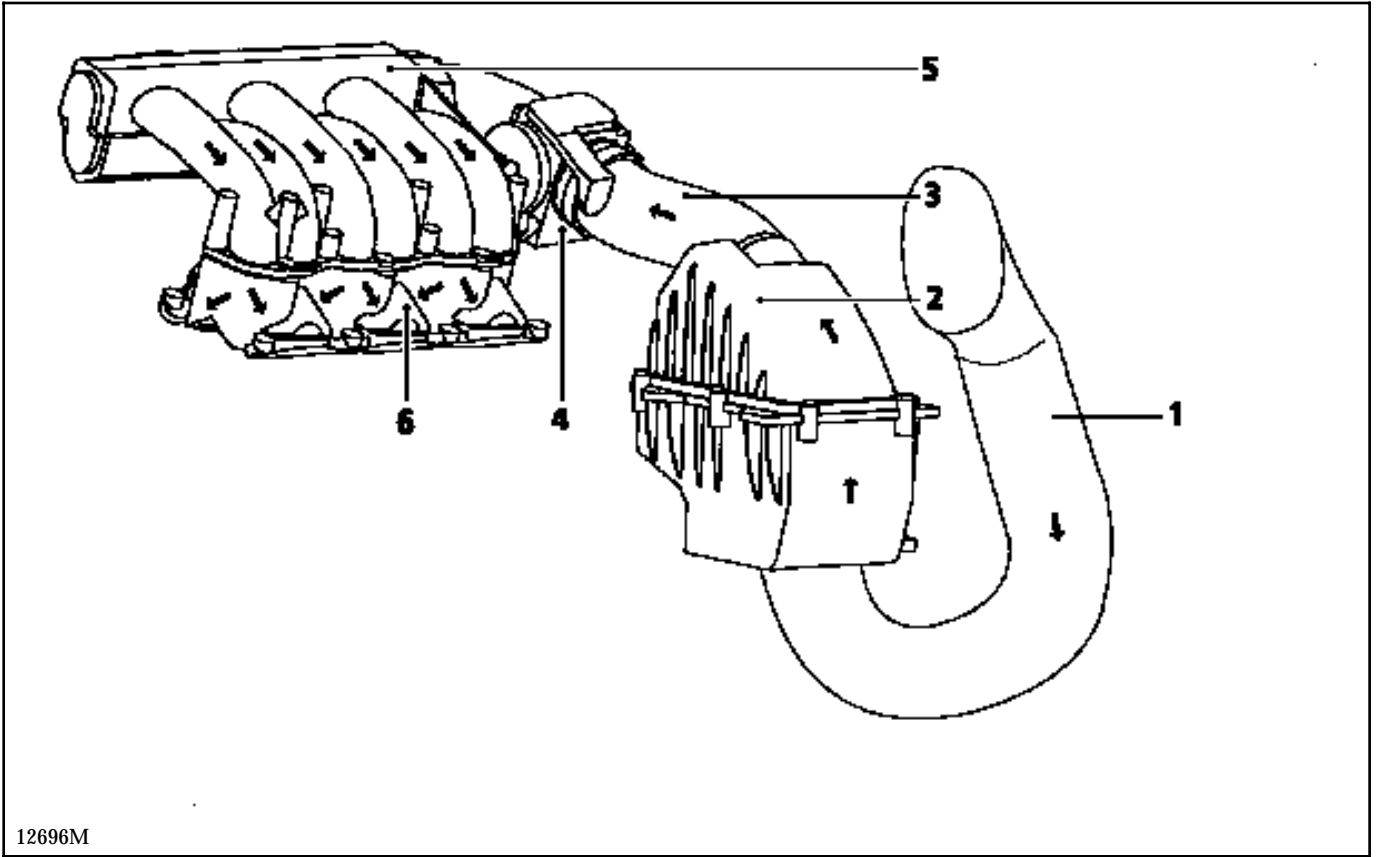

12696M

- 1 Air intake pipe
- 2 Air filter
- 3 Air intake pipe
- 4 Throttle body
- 5 Inlet manifold
- 6 Inlet distributor

To remove the two injector galleries, or simply the rear gallery, the inlet manifold and distributor have to be removed (see "inlet manifold" section), then the two galleries have to be separated from the distributor.

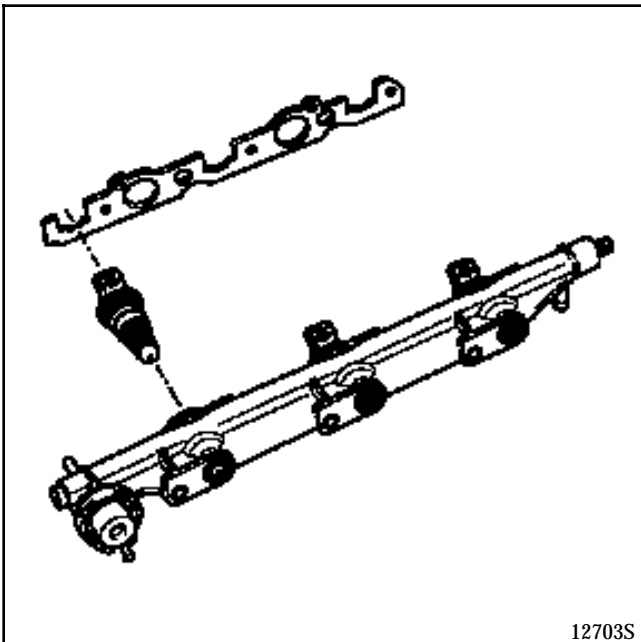
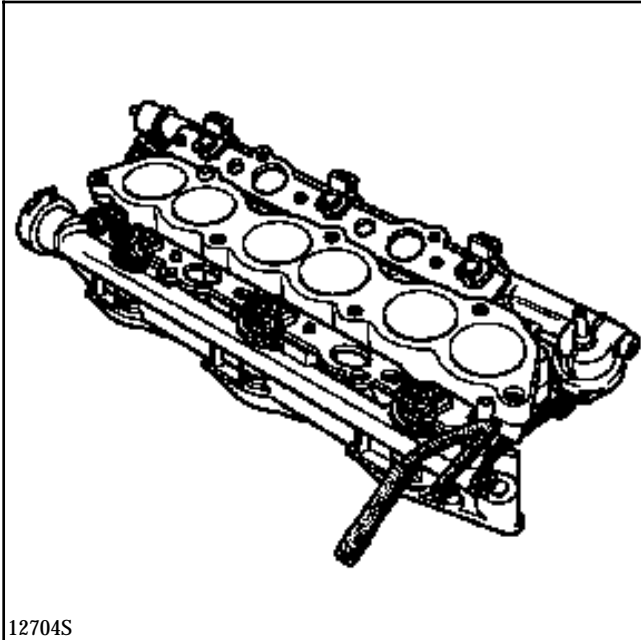

REMOVAL OF THE FRONT GALLERY ALONE

Disconnect the battery.

Remove the cover.

Disconnect:

- the high voltage coil wires (1),
- the oil vapour rebreathing pipe (3) (use tool **Mot. 1311-06**),
- the injectors,
- the fuel pipe (4) connecting the two injector galleries.

Remove:

- the three earth wire mounting bolts (2),
- the two bolts (5) mounting the harness onto the air filter,
- the mounting bolts of the harness support (7) and tilt this backwards,

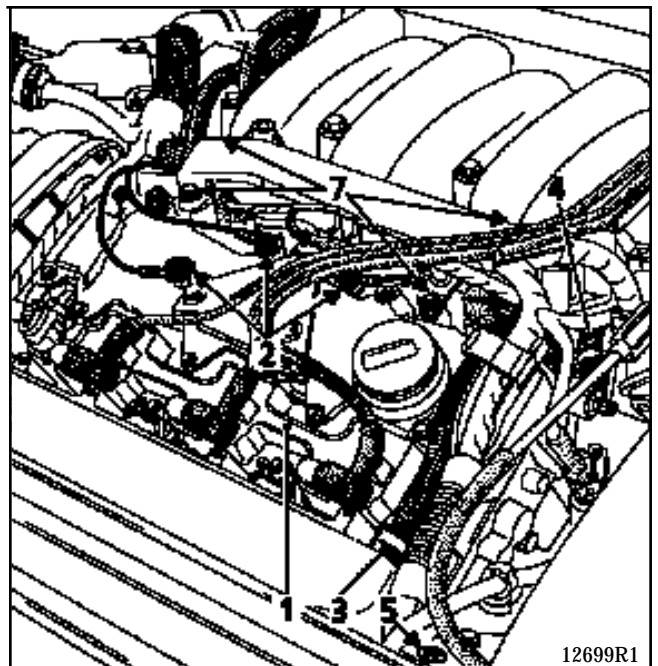

- the three bolts mounting the injector gallery onto the inlet distributor.

Lift the injector gallery and disconnect the vacuum pipe connected to the fuel pressure regulator.

Remove the injector gallery.

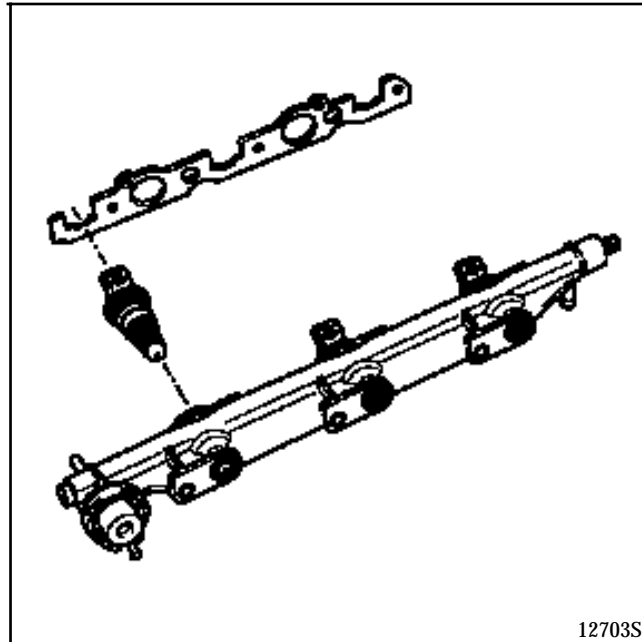

CHECKING THE FUEL SUPPLY AND PUMP FLOW PRESSURE

SPECIAL TOOLING REQUIRED	
Mot. 1311-01	Fuel supply pressure control kit
Mot. 1311-03	Pressure measurement union

CHECKING THE PRESSURE

Remove the upper protective plastic cover on the cylinder head cover.

A quick release union specially designed for carrying out pressure measurements is fitted at the end of the injector gallery.

Use tool **Mot. 1311-03** to connect into this union. Tool **Mot. 1311-03** is to be added to the kit **Mot. 1311-01**.

Connect tool **Mot. 1311-03** to the 0; + 10 bars pressure gauge using the kit (**Mot. 1311-01**).

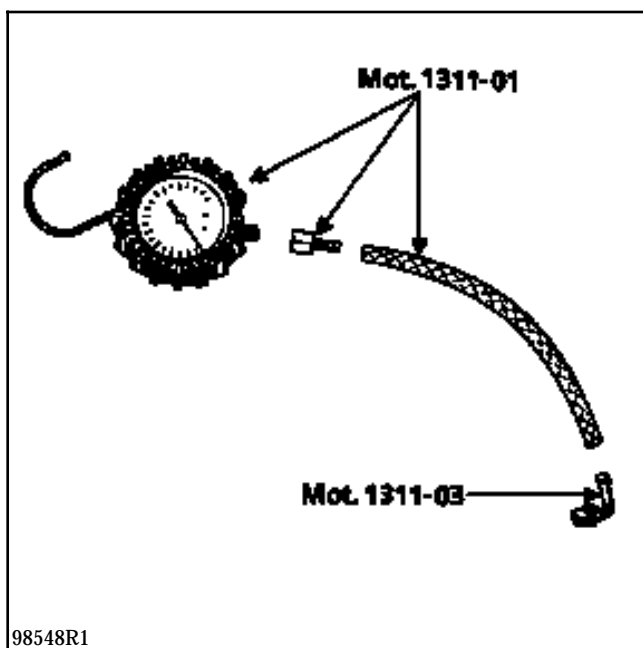

Shunt the terminals of the pump relay (A) in the engine connection unit. Check the pressure. It should be 3 ± 0.2 bars.

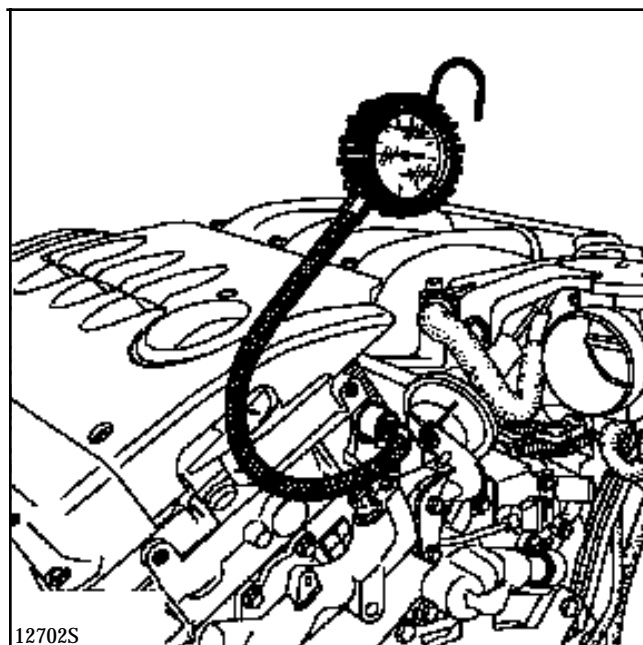
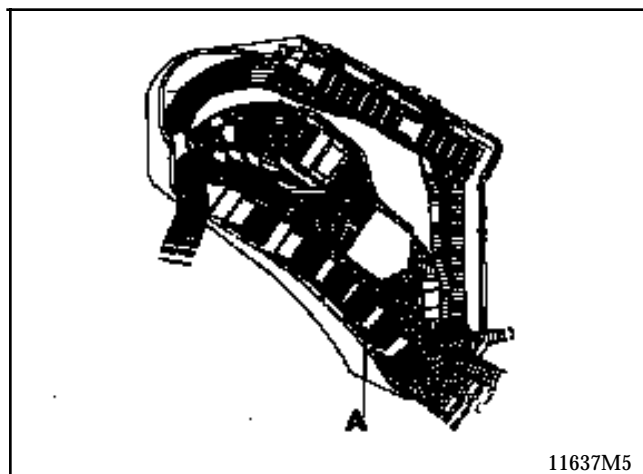

By applying a vacuum of **500 mbars** to the pressure regulator, the fuel pressure should be $2.5 \text{ bars} \pm 0.2$.

PUMP

Mechanical power assisted steering pump

13

POWER ASSISTED STEERING PUMP

SPECIAL TOOLING REQUIRED	
Mot. 453-01	Hose clamps

TIGHTENING TORQUES (in daN.m)	
Pump mounting bolt on cylinder head cover	4
Pump mounting bolt on support	2
Pump pulley bolt	1

REMOVAL

Place the vehicle on a lift.

Disconnect the battery.

Remove:

- the radiator grille and the radiator grille bar,
- the upper headlight carrier panel cross member.
- the accessories belt (see **Section 07 "Removal - Refitting of the accessories belt"**),

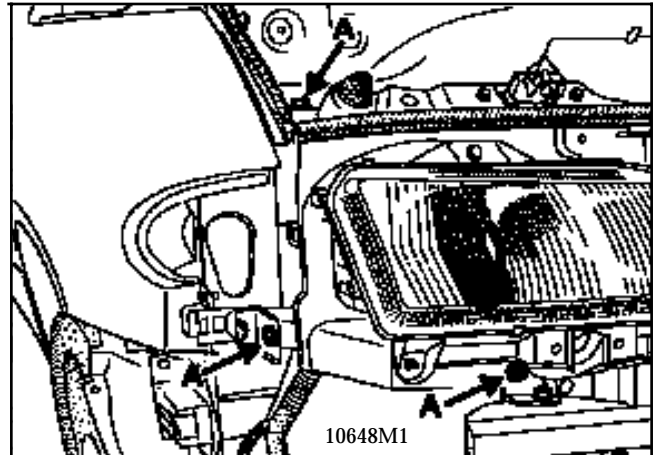
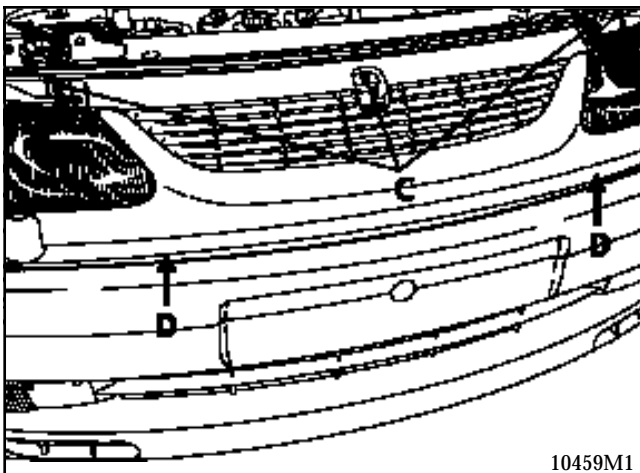

Remove the power assisted steering oil reservoir from its mounting and place it to one side.

Remove the power assisted steering pump pulley (4 bolts). To do this, follow the method described below.

Fit a clamp **Mot. 453-01** to the low pressure pipe coming from the reservoir.

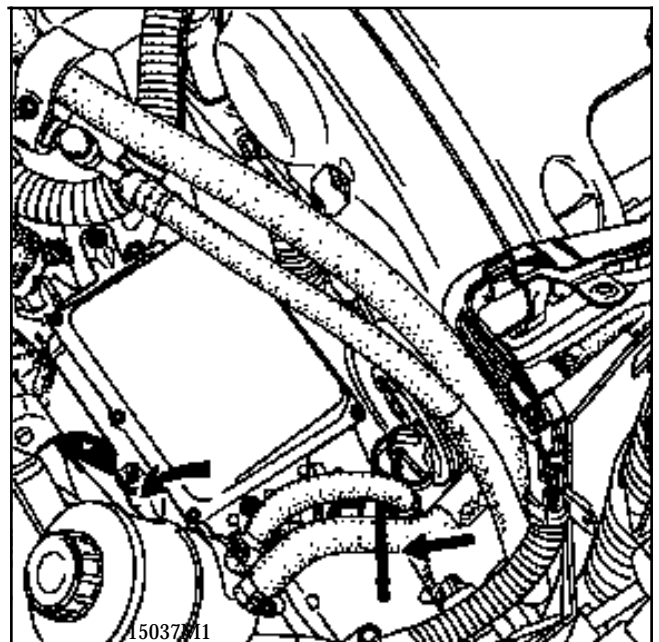

Slacken the power assisted steering pump unions.

If necessary, move the radiator slightly away from the engine.

Remove the power assisted steering pump by removing the three bolts securing it to its support.

NOTE: whilst carrying out this operation, protect the alternator from the power assisted steering fluid, which may leak out.

REFITTING

Refitting is the reverse of removal. Observe the correct tightening torques.

Refit the accessories belt as described in section 07.

NOTE: the accessories belt is automatically tensioned by a dynamic tensioner.

Fill and bleed the circuit.

PUMP

Mechanical power assisted steering pump

13

POWER ASSISTED STEERING PUMP PULLEY AND HUB

SPECIAL TOOLING REQUIRED		
Dir. 1083	Hub or pulley refitting tool	
Dir. 1308	Pulley extractor	
EQUIPMENT REQUIRED		
Extractor		

REMOVAL

Remove the pulley (4 bolts).

NOTE: In case of difficulty in removing the pulley, use tool **Dir. 1308** to extract it.

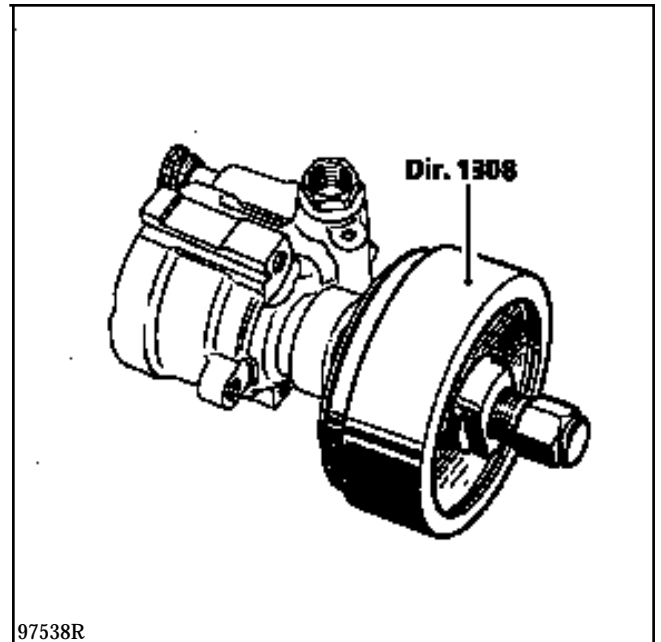
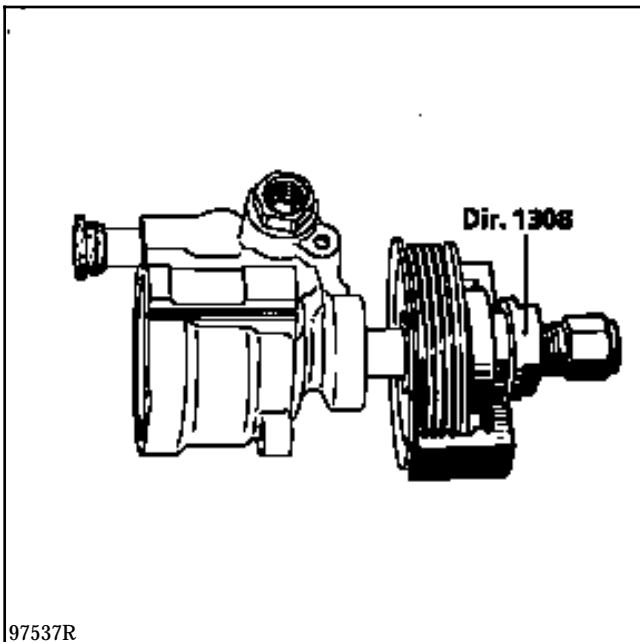

Use an extractor (releasing tool) to remove the hub and push on the pump shaft with a press.

REFITTING

Press on the hub using tool **Dir. 1083** until you obtain the measurement **X = 41 mm**.

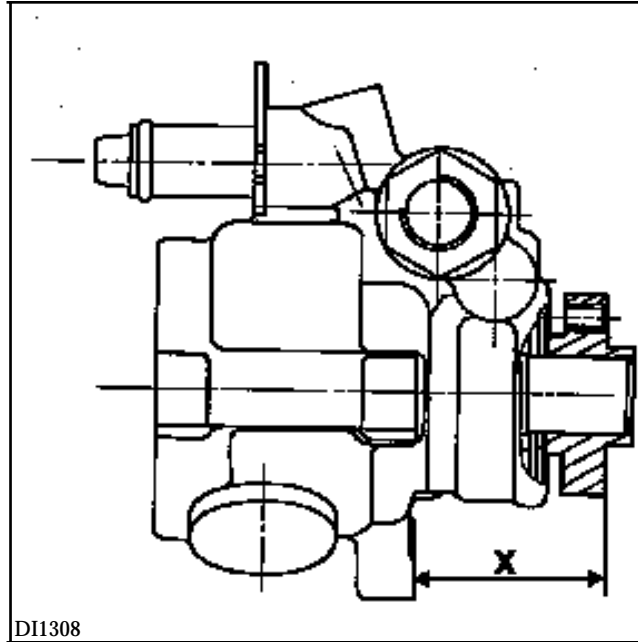

DI1308

PUMP

Mechanical power assisted steering pump

13

PRESENTATION OF THE ROUTING OF THE POWER ASSISTED STEERING PIPES

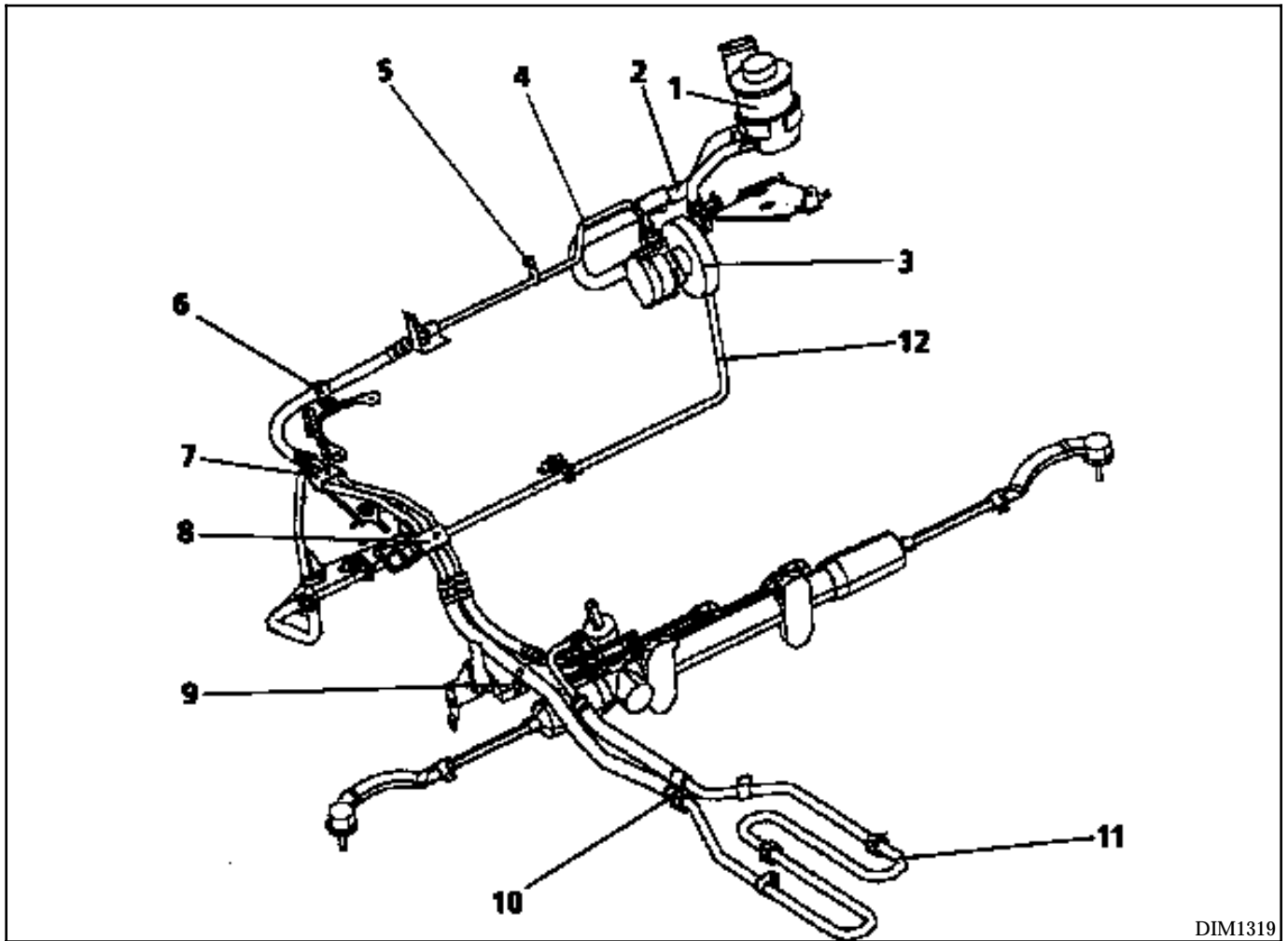

- 1 Power assisted steering fluid reservoir
- 2 PAS reservoir / pump pipe
- 3 Power assisted steering pump
- 4 PAS pump / steering rack valve pipe
- 5 Pressure gauge union
- 6 HP pipe mounting bracket on air filter
- 7 HP and LP pipe mounting bracket on front of driveshaft
- 8 HP and LP pipe mounting bracket on rear of driveshaft
- 9 Retaining clip on sub-frame
- 10 Exchanger unions
- 11 Exchanger
- 12 Exchanger / reservoir return pipe

POWER ASSISTED STEERING PIPE

SPECIAL TOOLING REQUIRED	
Mot. 453-01	Hose clamps

Disconnect the battery.

Use a syringe to remove as much oil as possible from the reservoir after removing the filter.

RESERVOIR / POWER ASSISTED STEERING PUMP PIPE (2)

REMOVAL

Unclip the pipe from the reservoir and the plastic clip.

Pull the pipe to the left to gain access to the clip on the pump.

Unclip the last clip on the pump and extract the hose.

REFITTING

Refitting is the reverse of removal.

LOW PRESSURE RETURN PIPE ON RESERVOIR (12)

REMOVAL

Disconnect the exchanger pipe under the floor (be careful of fluid running out).

Remove the air filter unit and its mounting. Disconnect the PAS reservoir pipe.

Unclip the cooling assembly pipe and the brackets on the driveshaft.

REFITTING

Refitting is the reverse of removal.

PUMP/VALVE HIGH PRESSURE PIPE (4)

REMOVAL

Disconnect the power assisted steering pipe (be careful of fluid running out). Use tool **Dir. 1282-01**.

Remove:

- the air filter unit and its mounting,
- the oil pressure switch (5).

Disconnect the PAS pump pipe. Use tool **Dir. 1282-01** vertically.

Unclip the cooling assembly pipe and the brackets on the gearbox.

REFITTING

Refitting is the reverse of removal.

COOLING

Fit clamps **Mot. 453-01** to the exchanger inlet and outlet.

REMOVAL

Unclip and remove the exchanger.

REFITTING

Refitting is the reverse of removal.

CIRCUIT OPERATING DIAGRAM

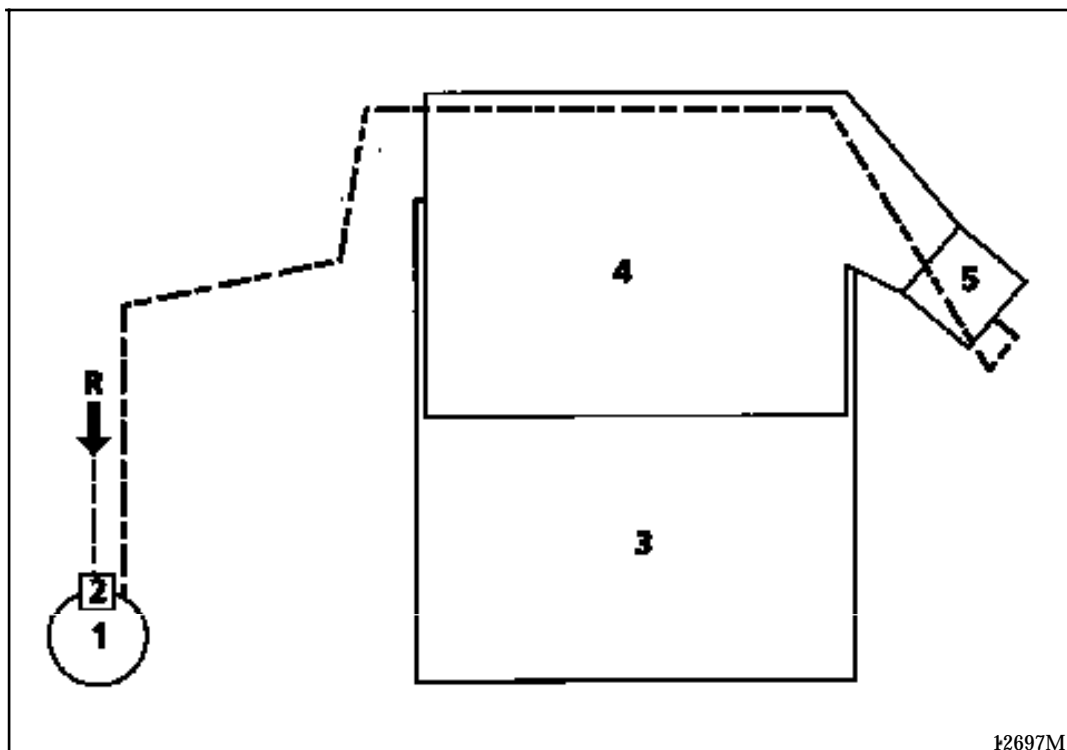

- 1 Canister
- 2 Solenoid valve (integrated in the canister)
- 3 Engine
- 4 Inlet manifold
- 5 Throttle body
- R Pipe coming from the fuel tank

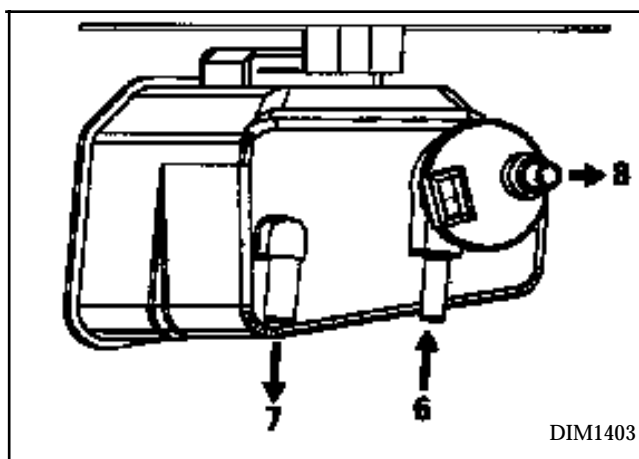

- 6 Inlet of vapours from the fuel tank
- 7 Breather
- 8 Outlet to bleed valve

OPERATING PRINCIPLE

The fuel tank breathes through the fuel vapour absorber (canister).

The fuel vapours are retained by the active carbon contained in the absorber (canister).

To ensure that the fuel vapours contained in the canister do not evaporate into the atmosphere when the fuel tank is opened, the fuel tank is isolated from the canister when the fuel filler cap is removed .

The fuel vapours contained in the canister are eliminated and burned by the engine.

In order to do this, the canister is connected to the inlet manifold by means of a pipe. This pipe is fitted with a solenoid valve which allows the bleeding of the canister.

The function of this solenoid valve is to provide a variable passage selection (function of the RCO signal produced by the injection computer).

CHECKING THE OPERATION OF THE CANISTER BLEED FUNCTION

A malfunction in the system could cause the idle speed to be unstable or the engine to stall.

Check that the circuit conforms (see diagrams).

Check the condition of the pipes up to the fuel tank.

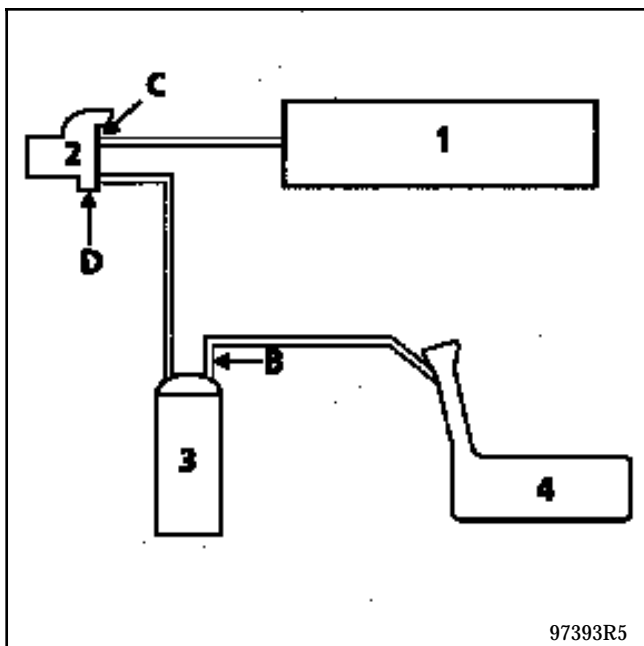

- 1 Inlet manifold
- 2 Canister bleed solenoid valve
- 3 Canister
- 4 Fuel tank

At idle speed, check by connecting a pressure gauge (- 3 ; +3 bars) (Mot. 1311-01) to the (D) outlet on the solenoid valve, that there is no vacuum (in the same manner, check that the command value read by the XR25 using #23 remains at a minimum $X = 0 \%$). **Is there a vacuum?**

YES Ignition off, use a vacuum pump to apply a vacuum of **500 mbars** to the solenoid valve at (C). The vacuum should not vary by more than **10 mbars** in **30 seconds**.
Does the pressure vary?

YES The solenoid valve is faulty, renew it. Air must also be blown into the pipe connecting the solenoid valve to the canister to eliminate any particles of active carbon.

NO There is an electrical fault - check the circuit.

NO Under bleeding conditions (engine not at idle speed, engine warm), there should be an increase in the vacuum (at the same time, the value for #23 on the XR25 should increase).

The fuel tank breather pipe can also be checked. After removing the filler cap, use a vacuum pump to apply a vacuum to the pipe at (B). If a vacuum can be applied to the pipe this shows that the overfilling valve is correctly sealed.

As soon as the filler cap is replaced, however, the vacuum should quickly disappear as the pipe is no longer blocked and the internal degassing chambers in the fuel tank are connected.

PRESENTATION OF THE CIRCUIT

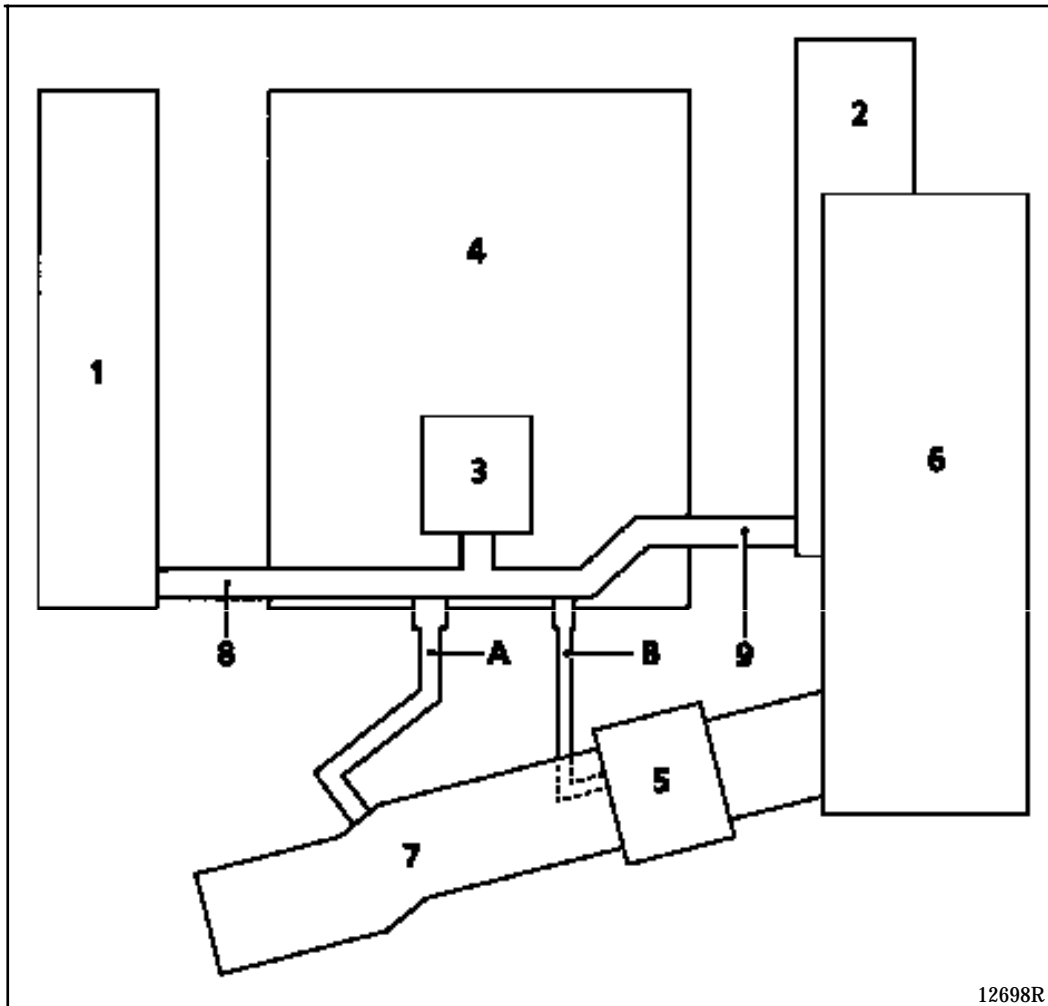

- 1 Front cylinder head
- 2 Rear cylinder head
- 3 Oil decanter
- 4 Engine
- 5 Throttle body
- 6 Inlet manifold
- 7 Air pipes
- 8 Front cylinder head cover pipe / oil decanter
- 9 Rear cylinder head cover pipe / oil decanter

A Circuit before the throttle body

This circuit is used for medium and high loads. The vapours are rebreathed by the vacuum in the air pipe (7).

B Circuit after the throttle body.

This circuit is used for low loads. The vapours are rebreathed by the vacuum between the throttle and the engine.

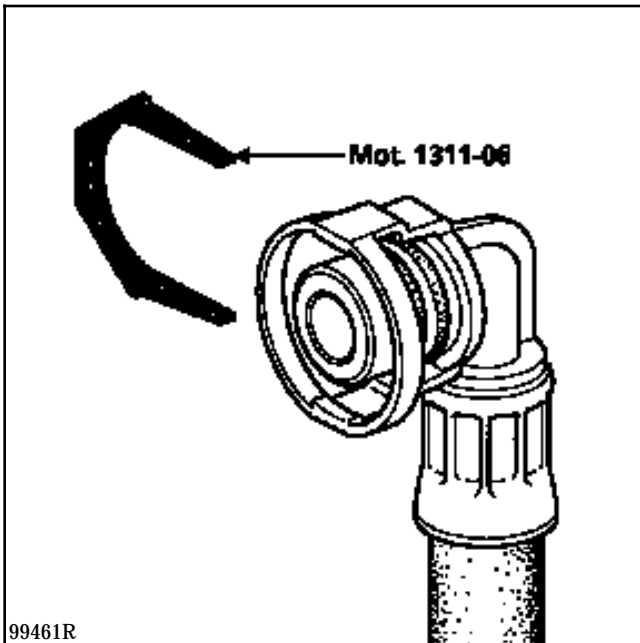
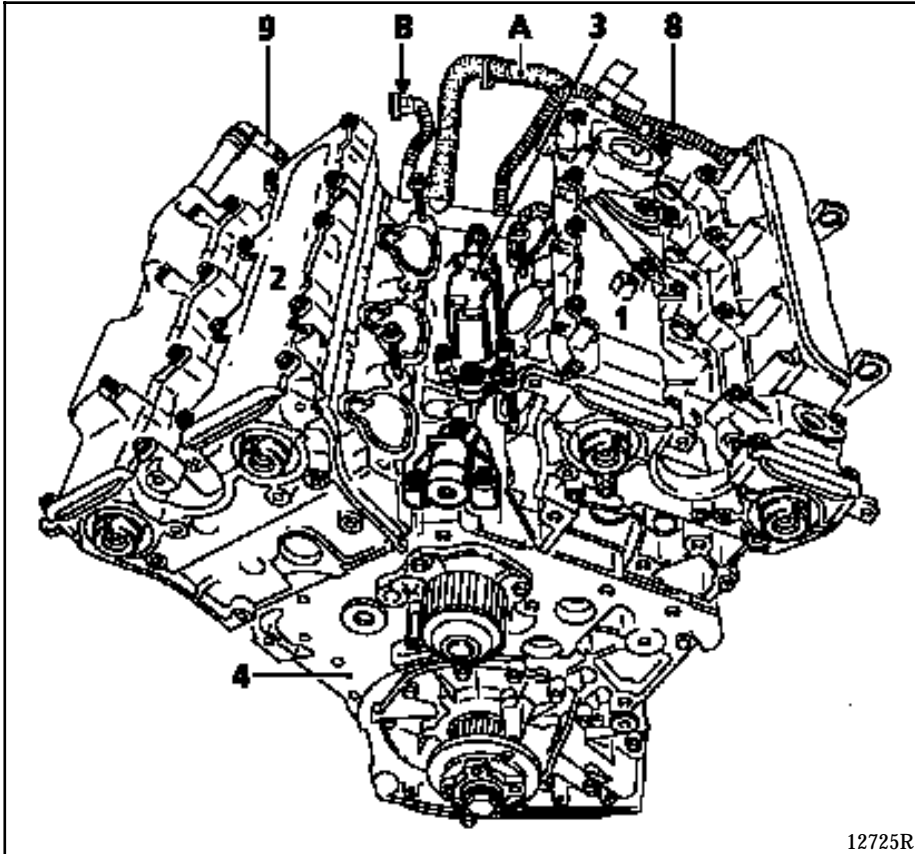

To remove the oil decanter, the inlet manifold and distributor have to be removed.

STARTING - CHARGING

Alternator

16

IDENTIFICATION

VEHICLE	ENGINE	ALTERNATOR	CURRENT
JE0 G	L7X	Valéo A 13 VI 201	120 A

CHECKING

After **15 minutes** of heating at a voltage of **13.5 volts**.

engine rpm	12 amps
1500	26
4000	94
6000	105

REMOVAL

Put the vehicle on a two post lift.

Disconnect the battery and the electrical connections of the alternator.

Remove:

- the right- hand engine undertray
- the accessories belt (see method in **Section 07 - Accessories belt**),
- the compressor (see **Section 62 - Air conditioning compressor**),
- the power assisted steering pump pulley,
- the alternator.

REFITTING

Refitting is the reverse of removal.

Top up the refrigerant fluid level (see **Section 62**).

STARTING - CHARGING

Starter motor

16

IDENTIFICATION

VEHICLE	ENGINE	STARTER MOTOR
JE0 G	L7X	VALÉO D7R17

The removal-refitting of the starter motor does not present any major difficulties and is carried out by removing the oil filter.

Remove the protective heat cover and the starter motor itself after disconnecting it electrically.

The exhaust downpipe does not need to be removed.

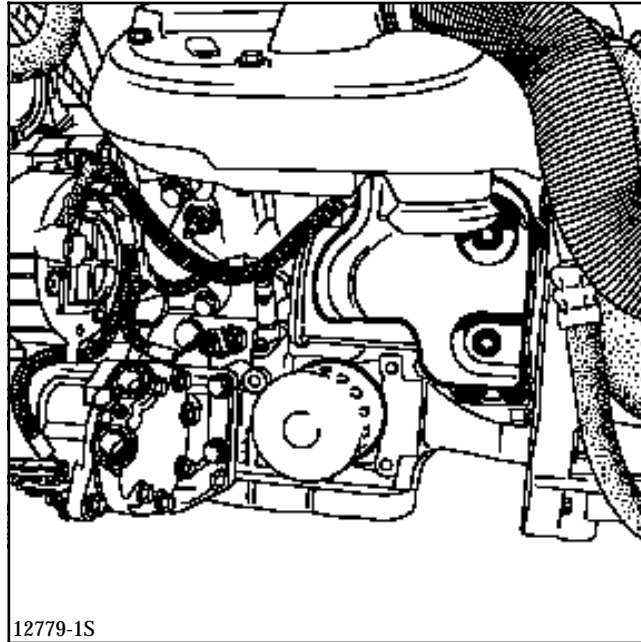

12779-1S

Top up the engine oil level.

The ignition is controlled by the injection/ignition computer.

The firing order is 1 - 6 - 3 - 5 - 2 - 4.

PRESENTATION

The system comprises:

- the injection computer (the ignition power stage is integrated into the computer),
- three dual output coils (1) ,
- six spark plugs,
- a pinking sensor .

COILS (1)

There are three, moulded into a single block and fitted onto the front cylinder head cover.

They cover the spark plugs of the front cylinders.

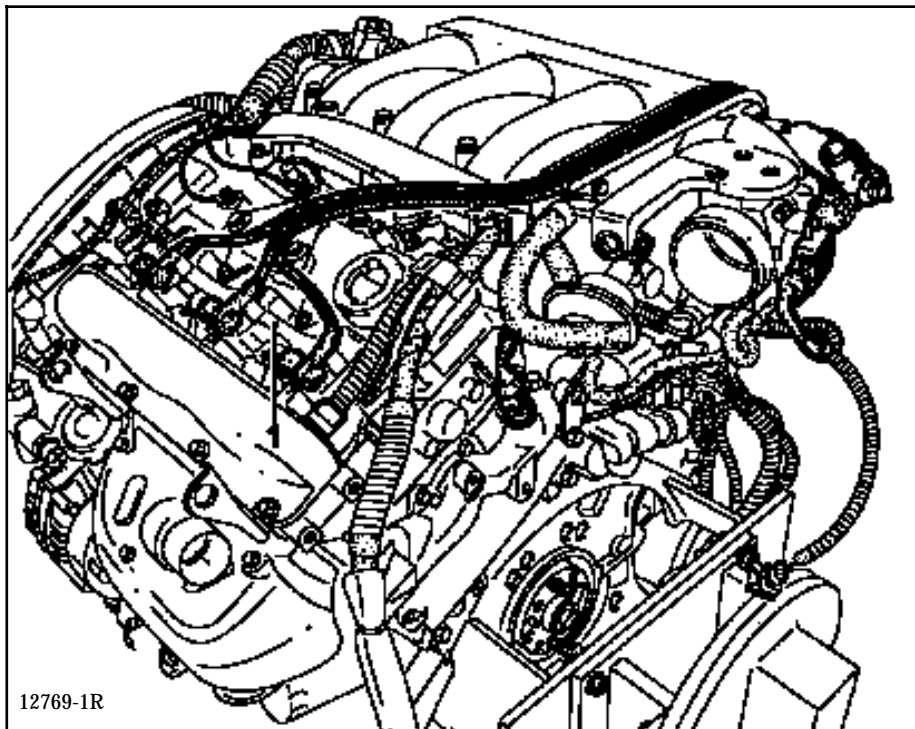

Track 1 of the computer controls the coil for cylinders 1 and 5.

Track 20 of the computer controls the coil for cylinders 2 and 6.

Track 21 of the computer controls the coil for cylinders 3 and 4.

It is possible to check this using the XR25 kit, fiche n° 47.

PLUGS

NGK PFR 6 E - 10

Gap: **1.0 mm** (adjustable)

Tightening torque: **3 daN.m.**

FRONT CYLINDERS

These are removable once the engine cover and the coils have been removed (1).

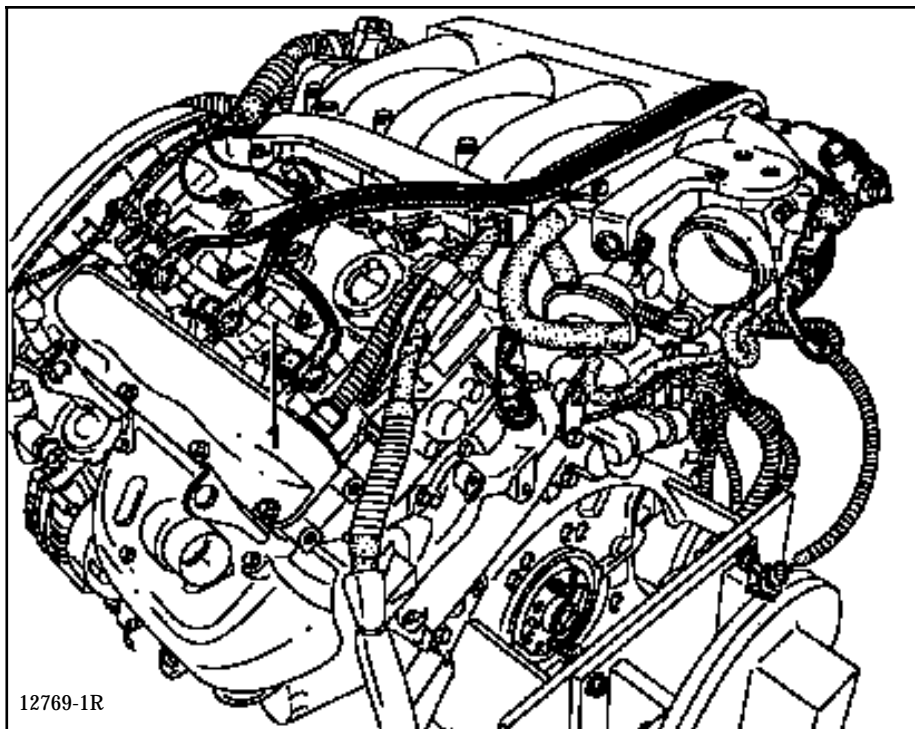

REAR CYLINDER

They can be removed once the inlet manifold (2) has been removed.
See the method for removal and refitting **Section 12 "inlet manifold"**

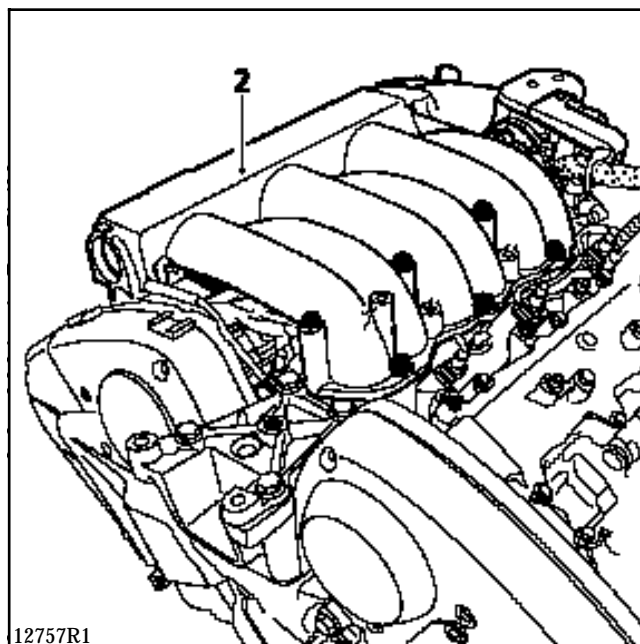

To remove the plugs, use the plug kit, **Ele 1382**.

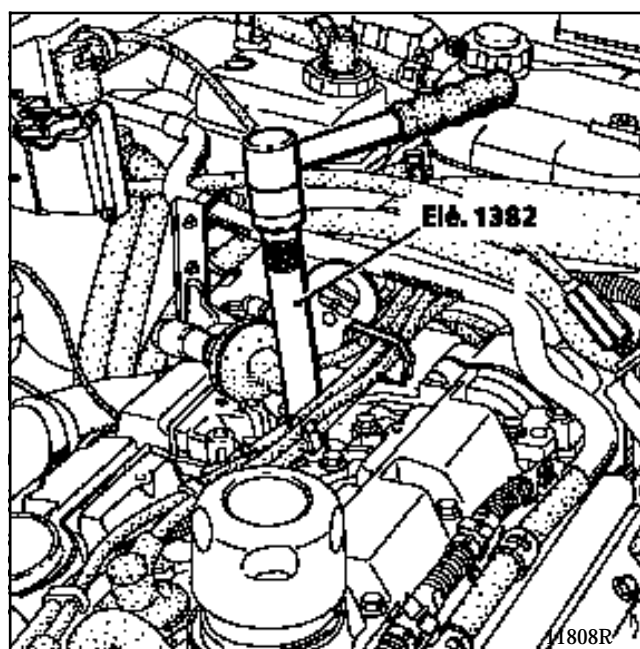

SPECIAL NOTES FOR MULTIPOINT INJECTION

- 55 track BOSCH MP7.0 computer.
- Semi-sequential multipoint injection, injectors controlled two by two (injectors for cylinders **1 and 5 / 3 and 4 / 2 and 6**).
- Static ignition with three dual output coils.
- Canister bleed solenoid valve controlled by RCO signal.
- Antipercolation function (controlling fans at low speed).
- Idle speed correction depending on :
 - air conditioning,
 - power assisted steering pressostat,
 - battery voltage.
- Injection warning light on instrument panel operational.
- The maximum engine speed is **6 560 rpm**.
- Use of the fault-finding fiche n° 47.
- In case of a fault in the coolant temperature sensor, the computer indicates defect mode for #02 (69°C engine running).
- In case of a fault in the air temperature sensor, the computer indicates defect mode for #03 (39°C engine running).
- 2nd generation series type engine immobiliser.

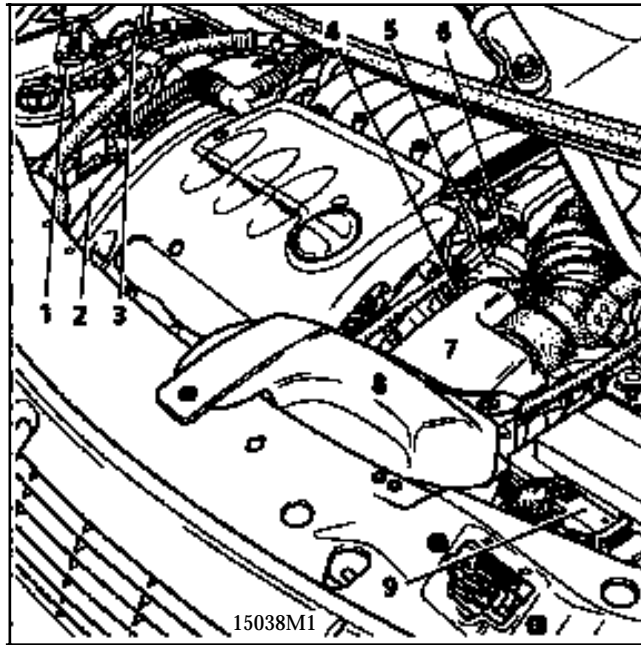

- 1 Fuel vapour recycling solenoid valve on the canister
- 2 Injection computer
- 3 Fuel vapour rebreathing circuit excess pressure valve
- 4 Fuel pressure socket
- 5 Cruise control regulator LDA
- 6 Accelerator cable
- 7 Air filter
- 8 Air deflector
- 9 Automatic transmission computer

INJECTION

Location of components

- 3 Canister bleed solenoid valve

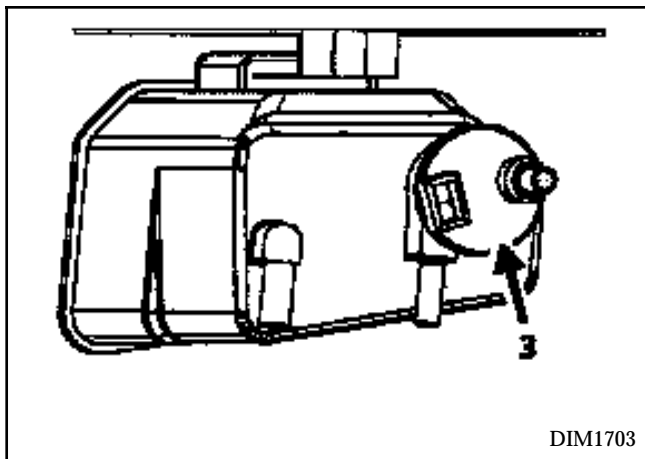

- 13 Air temperature sensor
- 21 Air filter

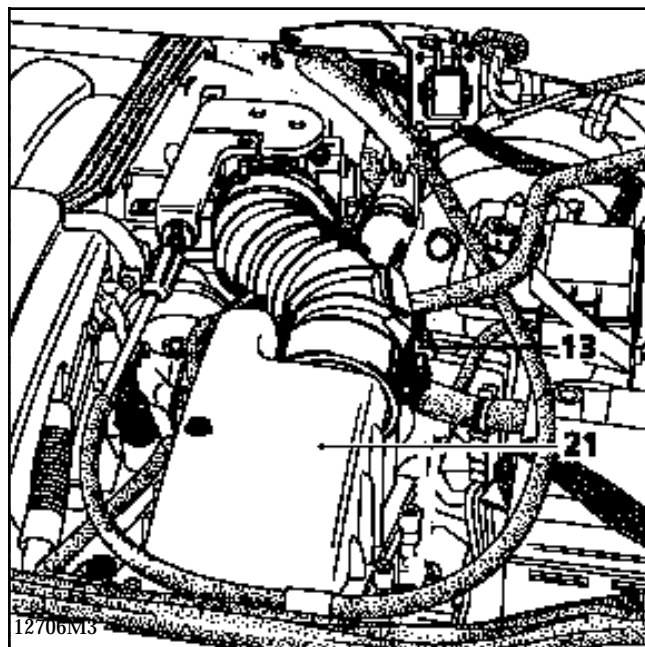

- 5 Pressure sensor
- 11 Throttle position potentiometer

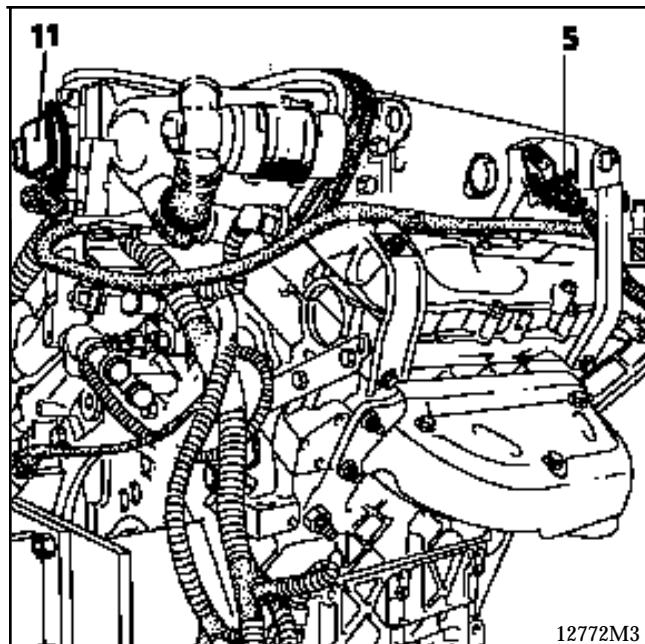

- 7 Oxygen sensor

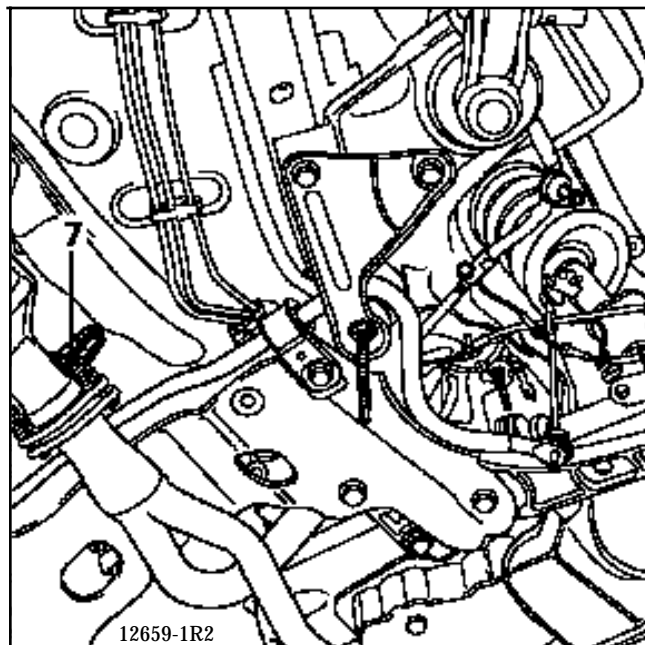

Injection computer

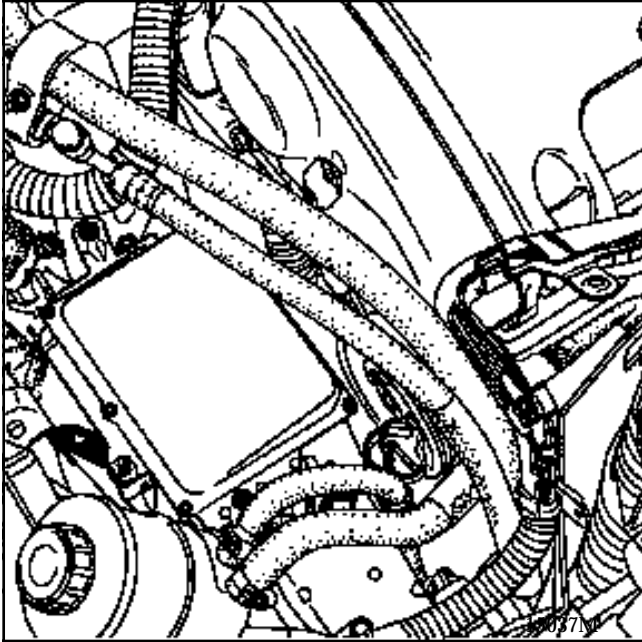

8 Pinking sensors

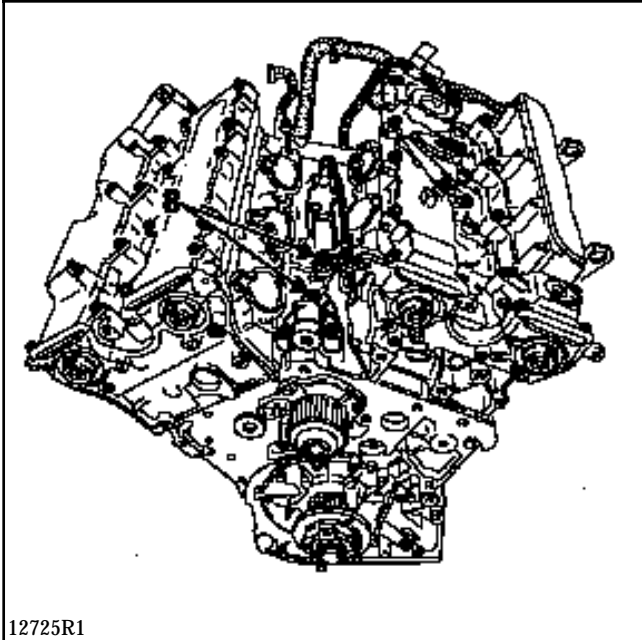

23 Coolant temperature sensor
25 Coils

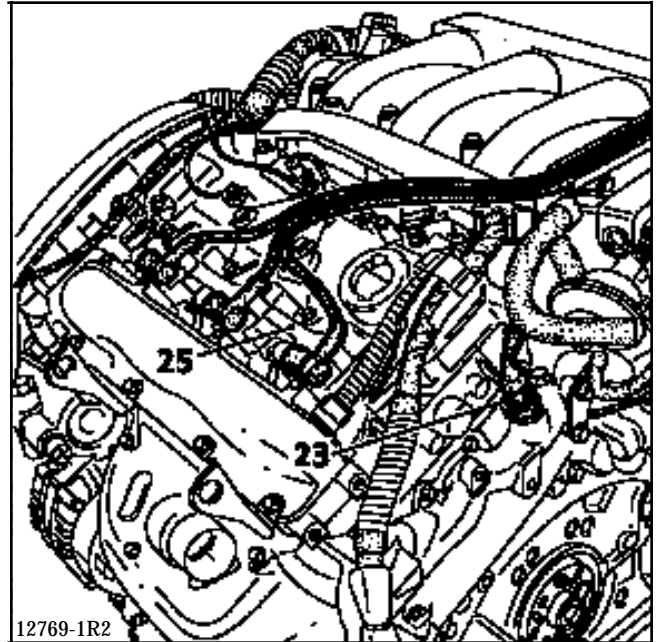

10 Idle speed regulation solenoid valve
22 TDC sensor

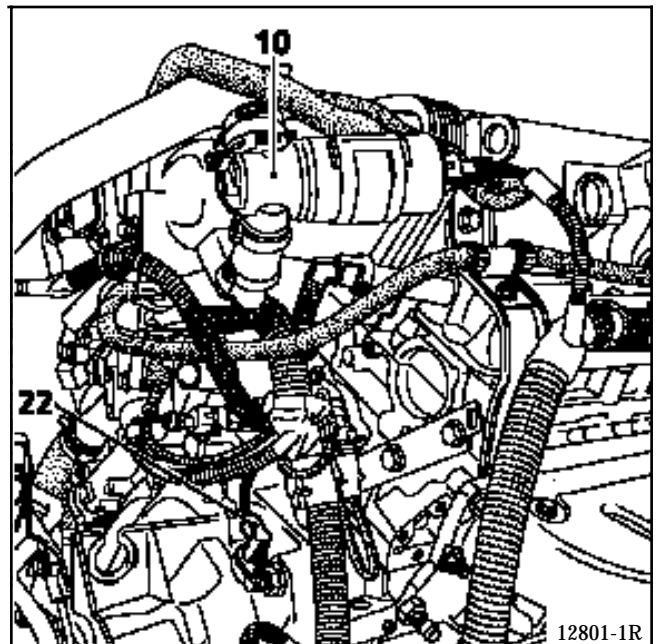

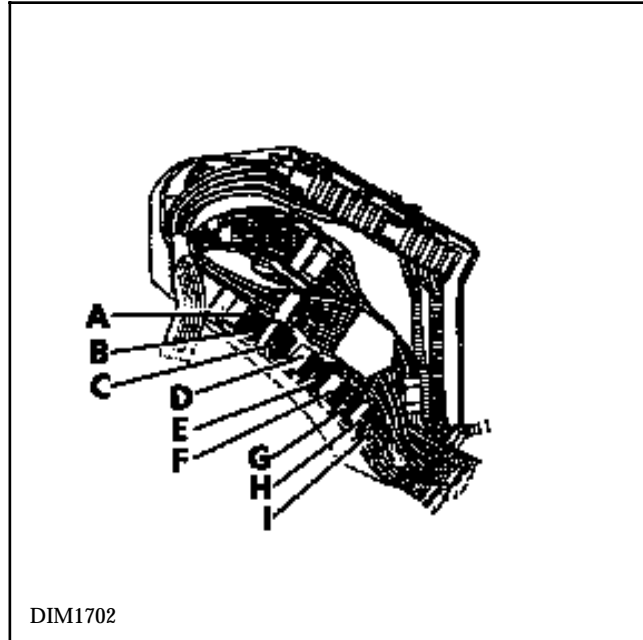

ENGINE CONNECTION UNIT RELAY:

- A Main beam headlights
- B Dipped headlights
- C Heating vent
- D Starter motor
- E Not used
- F Injection
- G Ignition
- H Oxygen sensor
- I Fuel pump

INJECTION

Engine immobiliser function

17

This vehicle is fitted with a 2nd generation immobiliser system. In order to function, the injection computer **MUST** have been programmed with the immobiliser code.

REPLACING THE INJECTION COMPUTER

The computer is supplied uncoded. After replacement, the vehicle code must be programmed into it, then the immobiliser function must be checked to determine whether it is operating correctly.

To do this, switch on the ignition for a few seconds and then switch it off again.

CHECKING THE IMMOBILISER FUNCTION

Remove the key from the ignition switch, after **10 seconds** the red immobiliser warning light should flash (to check that it is impossible to start the engine, refer to Technical Note 2725).

IT IS NOT POSSIBLE TO CARRY OUT A TEST ON A VEHICLE USING A COMPUTER FITTED TO ANOTHER VEHICLE OR BORROWED FROM THE STORE.

PRINCIPLE FOR ILLUMINATION OF THE INJECTION FAULT WARNING LIGHT ON THE INSTRUMENT PANEL

- **Vehicle with engine immobiliser system deactivated**

For certain equipment, when the ignition is switched on, the injection warning light illuminates for **3 seconds** then extinguishes.

When the doors are locked, the red immobiliser warning light, which was previously flashing, extinguishes. When the ignition is switched on, it illuminates for **3 seconds** then extinguishes.

- **Vehicle with engine immobiliser system activated**

When the ignition is switched on, the computer does not identify the code and prevents the vehicle being started. The injection warning light illuminates for **3 seconds** then extinguishes.

Before the ignition is switched on, the red immobiliser warning light flashes. When the ignition is switched on, this warning light flashes twice as fast.

If an immobiliser system fault is detected when the engine is running, the injection warning light illuminates or flashes (depending on equipment) in the engine speed range between idle and **1500 rpm** approximately.

- **Injection system component fault**

Faults on the following components will cause the warning light to illuminate:

- absolute pressure sensor,
- throttle position potentiometer,
- injectors,
- pinking sensor,
- idle speed regulation solenoid valve.

AT COMPUTER/INJECTION COMPUTER CONNECTION

"Park" / "neutral" position information and torque reduction.

These two items of information are transmitted via a single track on the injection computer.

Torque reduction is carried out when changing up and down gears.

AIR CONDITIONING/INJECTION COMPUTER CONNECTION

The electrical connection:

- from the air conditioning computer to the injection computer is carried out by one wire. This track only transmits the information that the air conditioning is operating. The injection computer deduces that the air conditioning has been selected: track 40,
- from the injection computer to the air conditioning computer is carried out by one wire. This track transmits the compressor operation authorisation and prevention information: track 23

PROGRAMMING FOR OPERATION OF THE COMPRESSOR

During certain operating phases, the injection computer prevents operation of the compressor.

Starting the engine

The compressor is prevented from operating for **2 seconds** after the engine has been started.

Thermal protection

The compressor clutch is prevented from engaging if the coolant temperature is greater than or equal to **+ 115°C** or if the temperature is lower than or equal to **0°C**.

Over-revving protection

The compressor is prevented from operating if the engine speed is greater than **6000 rpm**.

Performance restoration

The compressor is prevented from operating according to an injection map including the engine speed and the angle of the throttle (example: at **1000 rpm** the compressor is cut when the throttle is open by **70%**; at **4500 rpm**, it is cut when the throttle is open by **90 %**).

POWER ASSISTED STEERING PRESSOSTAT - INJECTION COMPUTER CONNECTION

The injection computer receives information from the power assisted steering pressostat. This information depends on the pressure in the hydraulic circuit. The higher the pressure, the more energy is absorbed by the power assisted steering pump.

In order to compensate for this energy absorption, the injection computer increases the opening percentage of the idle speed regulation solenoid valve.

The information is received on track 54 of the injection computer. When the pressostat is closed, the computer receives an earth. The idle speed is increased to **720 rpm**.

IDLE SPEED CORRECTION DEPENDING ON THE BATTERY VOLTAGE

The aim of this correction is to compensate for the decrease in voltage due to the operation of consumers when the battery voltage is low. In order to do this, the idle speed is increased, thus allowing the rotation of the alternator to be increased, and the charging voltage to be increased.

The lower the voltage, the greater is this correction. The engine speed correction is therefore variable. It begins when the voltage falls lower than **12.4 Volts**. The correction starts from nominal engine speed and may reach a maximum of **800 rpm**.

IDLE SPEED CORRECTION DEPENDING ON AIR CONDITIONING SELECTION

If the air conditioning is selected, the idle speed is fixed at **700 rpm**.

INJECTION

Adaptive idle speed correction

17

PRINCIPLE

Under normal warm engine operating conditions, the RCO idle speed value for #12 varies between an upper and a lower value to obtain the nominal idle speed.

If the engine operating conditions are different (running in, engine contaminated...) the RCO idle speed value may be situated close to the upper or lower value.

Adaptive correction (#21) for the RCO idle speed (#12) allows for compensations to be made for slow variations in the engine's air requirements, thus bringing the RCO (#12) back to an average nominal value.

This correction is only effective if the coolant temperature is greater than 80°C and if the engine is in the nominal idle speed regulation phase.

RCO IDLE SPEED VALUES AND ADAPTIVE CORRECTION

Nominal idle speed (#06)	$X = 650 \text{ rpm}$
R.C.O. idle speed (#12)	$20 \leq X \leq 40$
Adaptive idle speed (#21)	Threshold: - minimum: - 12.5 - maximum: +12.5

INTERPRETATION OF THESE GATE VALUES

If there is an excess of air (air leak, throttle stop incorrectly set...) the idle speed increases, the RCO idle speed value for #12 decreases to return to the nominal speed; the RCO idle speed adaptive correction value for #21 decreases to recentre the RCO idle speed for #12.

If there is a lack of air (pollution, etc.), the strategy is reversed:

The RCO idle speed for #12 increases and adaptive correction for #21 also increases, in order to reset #12 to an average nominal value.

IMPORTANT: after erasing the computer memory, (disconnecting the battery) the engine must be allowed to run at idle speed for 10 minutes, before returning the vehicle to the customer, so that the adaptive correction may correctly reset itself.

OXYGEN SENSOR VOLTAGE (#05)

Reading of #05 on the XR25: the value read is the voltage transmitted to the computer by the oxygen sensor; this is expressed in Volts (the value actually varies between 0 and 1000 millivolts).

When the engine is in the loop mode, the value of the voltage should fluctuate rapidly and should be between $50 \pm 50 \text{ mV}$ (lean mixture) and $850 \pm 50 \text{ mV}$ (rich mixture) and vice versa.

The smaller the gap between the maximum and minimum values, the less accurate the information from the sensor (the gap is usually at least 500 mV).

RICHNESS CORRECTION (#35)

The value given under #35 on the XR25 represents the average of the richness corrections made by the computer according to the richness of the burnt mixture as detected by the oxygen sensor (the oxygen sensor analyses the oxygen content of the exhaust gases directly from the richness of the burnt mixture).

The richness correction has a centre point of 1 (experience has shown that, under normal operating conditions, #35 is located close to 1 with only a small amount of variation).

- Value lower than 1: request for fuel mixture to be made leaner
- Value greater than 1: request for fuel mixture to be made richer

ENTRY INTO THE RICHNESS REGULATION MODE

Loop phase

The entry into the richness regulation mode becomes operational after the timed starting period if the coolant temperature has reached 9°C .

The timed starting period is dependent on the coolant temperature:

- at 20°C it is a maximum of 25 seconds
- at 80°C it is a maximum of 8 seconds

if richness regulation has not yet started, #35 = 1

Non-loop mode

When richness regulation is occurring, the operating phases when the computer ignores the voltage information from the oxygen sensor are:

- Full load : #35 = 1
- Sharp acceleration: #35 = 1
- Deceleration with no load information (injection cut): #35 = 1
- Oxygen sensor fault: #35 = 1

DEFECT MODE IN THE EVENT OF AN OXYGEN SENSOR FAULT

If an oxygen sensor fault is present and recognised and if the fault has already been stored, the system enters the open loop mode directly (#35 = 1).

PRINCIPLE

In the loop mode (see section 17 "Richness regulation"), richness regulation (# 35), corrects the injection timing to give fuel metering which is as close as possible to richness 1. The correction value is close to 1.

However, variations may affect the components of the injection system, causing the correction to alter in order to obtain richness 1.

Adaptive correction allows the injection mapping to be adjusted to recentre the richness regulation to 1 and ensure a constant authority of correction to make it richer or leaner.

Adaptive correction to richness regulation has two parts:

- adaptive correction for average and high engine loads (#30),
- adaptive correction for idle speed and low engine loads (#31).

$0.75 \leq \#30 \leq 1.25$
$-1 \leq \#31 \leq +1$

These values should only be examined if they are read at idle speed.

Adaptive correction only takes place when the engine is warm, in the loop phase (#35 variable).

It will therefore be necessary to carry out a road test after reinitialising the computer.

ROAD TEST

Conditions:

- richness regulation active for over 20 seconds,
- engine warm (coolant temperature > 80°C).

Carry out a road test going through all the operating phases of the engine, from idle speed to full load (a 15 minute road test is sufficient).

Following this test, the corrections will be operational.

31 varies more significantly for idle speed and low loads and # 30 for average and high loads, but both are operational over all of the manifold pressure ranges.

The test should be followed by a normal, varied drive, covering 3 to 6 miles (5 to 10 km).

After the test, read the values for # 30 and # 31. Initially 1 and 0, they should have changed. If they have not, repeat the test, taking care to observe the test conditions.

INTERPRETATION OF THE VALUES COLLECTED FOLLOWING A ROAD TEST

If there is a lack of fuel (injectors dirty, fuel pressure and flow too low...), richness regulation # 35 increases to obtain the richness as close as possible to richness 1 and adaptive correction # 30 and # 31 increase until the richness correction returns to oscillate around 1.

If there is an excess of fuel, the situation is reversed:

Richness regulation # 35 reduces and adaptive correction # 30 and # 31 also reduces to recentre the richness correction (# 35) around 1.

NOTE: the analysis which may be made using # 31 remains difficult since this correction mainly operates for idle speed and low loads and is also very sensitive.

Hasty conclusions should not therefore be drawn from this gate value, rather the position of # 30 should be examined.

The information from these two gates gives an idea about the engine operation richness and may be used as a guide for fault finding. For them to be of use during fault finding, conclusions may only be drawn if the values are at the minimum or maximum correction thresholds and if both values have drifted in the same direction.

IMPORTANT: # 30 and # 31 should only be examined and analysed after a customer complaint, an operating fault and if they are at the threshold with the value for # 35 also offset.

SETTING UP DIALOGUE BETWEEN THE XR25 AND THE COMPUTER

- Connect the XR25 to the diagnostic socket.
- Switch on the ignition.
- Selector on S8
- Enter **D13**

11.NJ

COMPUTER IDENTIFICATION

The computer is not identified by reading a fault code but by reading the Part Number directly from the computer. After entering into dialogue with the computer:

ENTER **G70***

7700

XXX

XXX

The Part Number will then appear on the central display in three sequences.

Each sequence is displayed for approximately two seconds. The display is repeated twice .

ERASING THE MEMORY (ignition on)

After an operation on the injection system the computer's memory can be erased by using code **G0**** .

DESCRIPTION OF FAULT FINDING PHASES

The process described below is to be carried out **in all cases of faults (even if the vehicle will not start)**, particularly the checking of the status and parameter information.

XR25 FAULT-CHECKING

This phase is the essential starting point for any intervention on the vehicle.

There are several constraints to the treatment of the bargraphs:

- A priority in the order of treatment when several bargraphs are illuminated.
- The interpretation of a bargraph depending on whether it is constantly illuminated or flashing .

1 - Order of priority

A series of illuminated bargraphs corresponding to the sensors with the same 12 V or having the same earth, indicates a fault in this source. These priorities are dealt with in the "NOTES" section of the fault-finding of the bargraph concerned.

2 - Input / output fault bargraphs

a) Illuminated:

The fault is present: deal with the fault following the method described in the "BARGRAPH TREATMENT" section.

b) Flashing:

Note the bargraphs displayed on the XR25.

Erase the memory of the computer and attempt to re-illuminate the bargraph: ignition on, idle speed (or at starter speed) or by means of a road test.

If the bargraph has re-illuminated (fixed or flashing):

The fault is present once again. In this case, deal with the fault bargraph (the "NOTES", section of the fault finding of the bargraph concerned, may tell you something about the conditions for illumination of the bargraph)

If the bargraph has not re-illuminated, check:

- the electrical lines which correspond to the flashing fault,
- the connectors of these lines (for rust, bent pins...).
- the resistance of the component found to be faulty.
- the cleanliness of the wires (insulation melted or cut, friction..).

3 - Erasing the memory

To erase the memory of this vehicle's computer, use command G0** on the XR25.

Fault finding - Introduction

4 - Absence of bargraphs

If no more fault bargraphs are illuminated on the XR25, a status and parameter check should be carried out. This may help to locate a problem.

XR25 STATUS AND PARAMETER CHECK

Status and parameter check :

The status and parameter check is aimed at checking the statuses and parameters which do not illuminate any fault bargraphs if they are outside of permitted tolerance values. This phase allows:

- Faults to be found without illumination of fault bargraphs which may correspond to a customer complaint (example: absence of no load information causing an unstable idle speed).
- Correct operation of the injection to be checked and the risk of faults appearing shortly after repair to be eliminated.

This section contains fault-finding for statuses and parameters, under their test conditions.

If a status does not operate normally or a parameter is outside permitted tolerance values, consult the fault-finding page indicated in the "Fault-finding" column.

XR25 CHECK CORRECT

If the XR25 check is correct, but the customer complaint persists, the problem must be dealt with through customer complaints.

Dealing with customer complaints

This section has fault charts, which suggest a series of possible causes of the problem.

These lines of enquiry must only be used in the following cases:

- No fault bargraph appears on the XR25.
- No faults are detected during the status and parameter check.
- The vehicle is not operating correctly

POST-REPAIR CHECK

This operation is a simple check of the repair (by a command, or by an XR25 command mode...).

This makes it possible to check that the system upon which the operation has been carried out is electrically correct.

It is an introduction to the road test.

Example: The fuel pump control circuit has been repaired. In this case it must be verified that the pump operates when its command mode is used. This checks that the system is operating correctly electrically.

ROAD TEST

A road test is essential in order to guarantee correct operation of the vehicle and to test the quality of the repair. Its role is to ensure that no faults occur (or will occur) when driving.

In order to be significant, the road test is subject to special driving conditions (see this section).

NOTE: The road test may be carried out during a conformity check. It must be noted that if the battery is disconnected after the road test, the programmed values will be erased.

INJECTION

Fault finding - XR25 fiche

PRESENTATION OF XR25 FICHE N° 47 SIDE 1/2

N°47 1/2 S8 code : D 1 3 read : 11nJ	
1	<div style="display: flex; justify-content: space-between;"> <div style="width: 45%;"> <input type="checkbox"/> ILLUMINATED → FAULT TEST <input type="checkbox"/> EXTINGUISHED → TURN CARD </div> <div style="width: 50%; text-align: right;"> CODE PRESENT <input type="checkbox"/> </div> </div>
2	<div style="display: flex; justify-content: space-between;"> <div style="width: 45%;"> <input type="checkbox"/> COMPUTER </div> <div style="width: 50%; text-align: right;"> ENG. IMMOB. * 22 <input type="checkbox"/> </div> </div>
3	<div style="display: flex; justify-content: space-between;"> <div style="width: 45%;"> <input type="checkbox"/> * 03. AIR TEMPERATURE </div> <div style="width: 50%; text-align: right;"> O2 SENSOR * 23 <input type="checkbox"/> </div> </div>

FI218471

INJECTION

Fault finding - XR25 fiche

17

PRESENTATION OF XR25 FICHE N° 47 SIDE 2/2

N°47 2/2		read : 12nJ
1	<input type="checkbox"/> EXTINGUISHED → STATUS TEST <input type="checkbox"/> ILLUMINATED → TURN CARD	CODE PRESENT <input checked="" type="checkbox"/>
2	<input type="checkbox"/> PG ← THROTTLE POSITION → <input type="checkbox"/> PL	CONTROL MODES : G.. (If engine stopped) 10* Fuel pump circ. relay 11* Locking relay 12* AC compressor 14* Idle speed reg. valve relay 16* Bleed canister valve relay 21*1* Warn. light def. 2* Coolant temp. warn. light 25* Heater resistance 02 sensor 27*1* Cool. fan low speed 2* Cool. fan high speed 31*1* Injector cylinder no 1 2* Injector cylinder no 2 3* Injector cylinder no 3 4* Injector cylinder no 4 5* Injector cylinder no 5 36*1* Coil control n°1 & 5 2* Coil control n°2 & 6 3* Coil control n°3 & 4 50*x* ⚠ Vehicle programming 56*1* Read supplier n° 2* Read computer options 61* Visualisation of camshaft status
3	<input type="checkbox"/> FLYWHEEL SIGNAL ENG. IMMOB. ACTIVE <input type="checkbox"/>	
4	<input checked="" type="checkbox"/> PARK/NEUTRAL POSITION + APC COMPUTER <input type="checkbox"/>	
5	<input checked="" type="checkbox"/> COOLANT TEMP. WARN. LIGHTS INJ OR DEFECT <input type="checkbox"/>	
6	<input type="checkbox"/> FUEL MIXTURE REGUL. IDLING REGULATION <input type="checkbox"/>	
7	<input type="checkbox"/> FUEL PUMP CONTROL BLEED CANISTER <input type="checkbox"/>	
8	<input checked="" type="checkbox"/> LOWSPEED CRANTI-PERC. AIR COND. FAN UNIT → GV <input checked="" type="checkbox"/>	
9	<input type="checkbox"/> AIR COND. ACCEL. IDLING <input type="checkbox"/>	
10	<input type="checkbox"/> REQUEST → COMPRESSION AUTHOR. OR PROHIBITED <input type="checkbox"/>	
<h3 style="margin: 0;">BOSCH INJECTION (Status)</h3> <p style="margin: 5px 0;">Erase fault memory : G 0 ** Request fault test : G 02 *</p>		
11	<input type="checkbox"/> PAS PRESSOSTAT ACTIVE HEATING 02 SENSOR <input type="checkbox"/>	
12	<input checked="" type="checkbox"/> ELEC. W/SCREEN REQUESTED	
13	<input checked="" type="checkbox"/> ZERO OR TORQUE ADJ. TORQUE ADJUSTMENT 2 <input type="checkbox"/>	
14	<input type="checkbox"/> 3 TORQUE ADJUSTMENT 4 <input type="checkbox"/>	
15	<input type="checkbox"/> ZEROING MEMORISED FAULTS 02 SENSOR <input type="checkbox"/>	
16	<input checked="" type="checkbox"/> INJ. CUT-OUT VEHICLE SPEED > 30 KM/H <input type="checkbox"/>	
17	<input checked="" type="checkbox"/> ARGENTINA BRAZIL <input type="checkbox"/>	
18	<input checked="" type="checkbox"/> WITH AC COMPUTER CONFIGURATION WITH/OUT AC <input type="checkbox"/>	
19	<input checked="" type="checkbox"/> WITHOUT AT WITH MAN. G/BOX <input type="checkbox"/>	
20	<input checked="" type="checkbox"/> FAULT PRESENT XR25 MEMORY <input type="checkbox"/> 0 <input type="checkbox"/>	
<div style="display: flex; justify-content: space-between; align-items: center;"> <div style="text-align: center;"> <p>See procedure on REMINDER CARD C</p> <p>End of test : G 13 *</p> <p>Part No : G 70 *</p> <p>Diagnosed faults : Press V and 9</p> <p>Return to diag. mode : D</p> </div> <div style="border: 1px solid black; padding: 5px; display: inline-block;"> <p style="margin: 0;">18 ANG</p> </div> </div>		

FI218472

JMO021.0

REPRESENTATION OF BARGRAPHS



Illuminates when dialogue has been established with the product computer. If it remains extinguished:

- the code does not exist,
- there is a tool, computer or line fault.

REPRESENTATION OF THE FAULTS (always on a coloured background)



If illuminated, indicates a fault on the tested product, the associated text defines the fault.

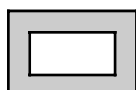

If extinguished, indicates that no fault has been detected on the product being tested.

REPRESENTATION OF STATUS (always on a white background)

Engine stopped, ignition on, no operator action

The status bargraphs on the fiche in the condition they would be in when the engine is stopped, ignition on, no operator action

- If on the fiche the bargraph is represented as

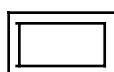

the test kit should give as information

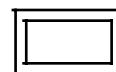

- If on the fiche the bargraph is represented as



the test kit should give as information



- If on the fiche the bargraph is represented as



the test kit should give as information

either

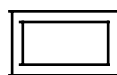

or



Engine running

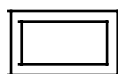

Extinguished when the function or condition specified on the fiche is no longer being met.



Illuminated when the function or condition specified on the fiche is being met.

Fiche n° 47 is a generic fiche used for several engines.

The various engines do not use all the bargraphs. To find out the bargraphs dealt with by the injection computer, after entering into dialogue with the computer, press the V and 9 buttons simultaneously.

The bargraphs dealt with will:

- illuminate permanently for fault bargraphs or status bargraphs which cannot be memorised,
- flash for fault bargraphs which can be memorised.

To return to fault finding mode, press button D.

Fault finding - Interpretation of XR25 bargraphs

<p style="margin: 0;">1</p> 	<p>Bargraph 1 RH side extinguished Fiche n° 47 side 1/2</p> <p><u>CODE PRESENT</u></p> <p>XR25 aid: No connection, CO, CC-, CC+</p>
---	--

NOTES	This bargraph should be illuminated for fault finding.
--------------	--

Test the XR25 on another vehicle.

Check:

- the injection and passenger compartment fuses,
- the connection between the XR25 and the diagnostic socket,
- the position of the selector (S8),
- the conformity of the cassette.

Repair if necessary.

Check:

- for + 12 V on track 16 and earth on track 4 of the diagnostic socket,
- the condition of the XR25 cable.

Repair if necessary.

Connect the bornier in place of the computer and check the insulation and continuity of the line:

Computer	2	→	Earth
Computer	14	→	Earth
Computer	19	→	Earth
Computer	24	→	Earth
Computer	55	→	7 Diagnostic socket
Computer	13	→	15 Diagnostic socket
Computer	18	→	F10 3A fuse
Computer	27	→	F38 30A fuse
Computer	37	→	3 Main relay
Computer	36	→	2 Main relay
Computer	16	→	2 Injectors 3 and 4
Computer	17	→	2 Injectors 1 and 5
Computer	35	→	2 Injectors 2 and 6

Repair if necessary.

Check for the presence of 12 V on tracks 1 and 5 of the main relay.

Repair if necessary.

Replace the main relay.

AFTER REPAIR	<p>Erase the computer memory using GO**.</p> <p>Try to start the vehicle. Switch on the ignition, then deal with the other faults.</p> <p>Remember to carry out a status and parameter check!</p>
---------------------	---

Fault finding - Interpretation of XR25 bargraphs

<p>2</p> 	<p>Bargraph 2 LH side illuminated</p> <p style="text-align: right;">Fiche n° 47 side 1/2</p> <p><u>COMPUTER</u></p> <p>XR25 aid: Computer faulty</p>
---	--

NOTES	None.
--------------	-------

<p>Connect the bornier in place of the computer and check the insulation and continuity of the line:</p> <table style="margin-left: 40px;"> <tr> <td>Computer</td> <td>37</td> <td>→</td> <td>5</td> <td>Main relay</td> </tr> <tr> <td>Computer</td> <td>36</td> <td>→</td> <td>2</td> <td>Main relay</td> </tr> </table> <p>Repair if necessary.</p>	Computer	37	→	5	Main relay	Computer	36	→	2	Main relay
Computer	37	→	5	Main relay						
Computer	36	→	2	Main relay						
<p>Check for the presence of 12 V on tracks 1 and 2 of the main relay. Repair if necessary.</p>										
<p>Replace the main relay.</p>										
<p>The computer is incorrect or faulty. Replace the computer.</p>										

AFTER REPAIR	<p>Erase the computer memory using GO**.</p> <p>Try to start the vehicle. Switch on the ignition, then deal with the other faults.</p> <p>Remember to carry out a status and parameter check!</p>
---------------------	---

Fault finding - Interpretation of XR25 bargraphs

<p style="margin: 0;">2</p> <div style="border: 1px solid black; width: 50px; height: 30px; margin: 5px auto; background-color: black;"></div>	<p>Bargraph 2 RH side illuminated Fiche n° 47 side 1/2</p> <p><u>ENGINE IMMOBILISER CIRCUIT</u></p> <p>XR25 aid: *22 = 1 dEF CO, CC-, CC+ line 50 of the computer *22 = 2 dEF Consult immobiliser fault finding</p>
---	---

NOTES	None
--------------	------

Connect the bornier in place of the computer and check the insulation, continuity and that there is no interference resistance of the wiring on track 50 of the computer and track B2 of the immobiliser unit. Repair if necessary.

If the fault persists, consult immobiliser fault finding.

AFTER REPAIR	<p>Erase the computer memory using GO**.</p> <p>Try to start the vehicle. Switch on the ignition, then deal with the other faults.</p> <p>Remember to carry out a status and parameter check!</p>
---------------------	---

Fault finding - Interpretation of XR25 bargraphs

<div style="text-align: center; font-weight: bold; margin-bottom: 5px;">3</div> 	<p>Bargraph 3 LH side illuminated Fiche n° 47 side 1/2</p> <p><u>AIR TEMPERATURE SENSOR CIRCUIT</u></p> <p>XR25 aid: *03 = CC0 => CC-line 44 of the computer *03 = CO1 => C0 or CC+line 44 of the computer</p>
--	--

NOTES	<p>If BG 4 LH side or BG 5 LH side or BG 6 RH side is also illuminated, check line 26 of the computer.</p>
--------------	--

<p>Connect the bornier in place of the computer and check the insulation, continuity and that there is no interference resistance on line:</p> <table style="margin-left: 40px; border: none;"> <tr> <td style="padding-right: 20px;">Computer</td> <td style="padding-right: 10px;">44</td> <td style="padding-right: 10px;">→</td> <td style="padding-right: 10px;">1</td> <td>Air temperature sensor</td> </tr> <tr> <td>Computer</td> <td>26</td> <td>→</td> <td>2</td> <td>Air temperature sensor</td> </tr> </table> <p>Repair if necessary.</p>	Computer	44	→	1	Air temperature sensor	Computer	26	→	2	Air temperature sensor
Computer	44	→	1	Air temperature sensor						
Computer	26	→	2	Air temperature sensor						
<p>Check the resistance of the sensor. Replace it if necessary.</p>										
<p>The problem is still not resolved! Replace the injection computer.</p> <p>IMPORTANT : The damage to the computer is probably due to an electrical shock. The cause of the damage must be found before a new computer is fitted.</p>										

AFTER REPAIR	<p>Erase the computer memory using GO**.</p> <p>Try to start the vehicle. Switch on the ignition, then deal with the other faults.</p> <p>Remember to carry out a status and parameter check!</p>
---------------------	---

Fault finding - Interpretation of XR25 bargraphs

<div style="border: 1px solid black; padding: 5px; width: 50px; margin: 0 auto;">3</div>	<p>Bargraph 3 RH side illuminated Fiche n° 47 side 1/2</p> <p><u>OXYGEN SENSOR CIRCUIT</u></p> <p>XR25 aid: *23 = CO => CO line 28 of the computer *23 = CC0 => CC- line 28 of the computer *23 = CC1 => CC+ line 28 of the computer *23 = 1 dEF => Richness loop phase *23 = 2dEF => sensor too old</p>
--	---

NOTES	<p>If BG 8 LH side is flashing, increase the engine speed to 2500 rpm for 5 minutes. If BG 8 LH side has become permanently illuminated, deal with the fault. If other bargraphs are illuminated, check the cleanliness of the vehicle earth.</p>
--------------	---

<p>*23 = CO *23 = CC0 *23 = CC1</p>	<p>Check the connection and condition of the oxygen sensor connector.</p> <hr/> <p>Connect the bornier in place of the computer and check the insulation, continuity and that there is no interference resistance on line:</p> <p style="margin-left: 40px;">Computer 10 —————> 3 Oxygen sensor Computer 28 —————> 4 Oxygen sensor</p> <p>Repair if necessary.</p> <hr/> <p>The fault persists! Replace the oxygen sensor.</p> <hr/> <p>The problem is still not resolved! The injection computer must therefore be replaced.</p> <p style="text-align: center;">IMPORTANT : The damage to the computer is probably due to an electrical shock. The cause of the damage must be found before a new computer is fitted.</p>
---	--

<p>*23 = 1 dEF</p>	<p>A problem is offsetting the richness regulation. Check if the fuel pressure is correct in the injector gallery. Check if there is a leak in the exhaust. Check if there is a leak in the canister bleed.</p>
--------------------	--

<p>*23 = 2 dEF</p>	<p>Erase the computer memory using GO**. Carry out a road test to clean the sensor. If the sensor fault reappears, replace the sensor.</p>
--------------------	--

AFTER REPAIR	<p>Erase the computer memory using GO**. Try to start the vehicle. Switch on the ignition, then deal with the other faults. Remember to carry out a status and parameter check!</p>
---------------------	---

Fault finding - Interpretation of XR25 bargraphs

<div style="border: 1px solid black; padding: 5px; width: 60px; margin: 0 auto;"> <p style="text-align: center; margin: 0;">4</p> </div>	<p>Bargraph 4 LH side illuminated Fiche n° 47 side 1/2</p> <p><u>COOLANT TEMPERATURE SENSOR CIRCUIT</u></p> <p>XR25 aid: *04 = CC0 => CC- line 45 of the computer *04 = CO1 => CO or CC+ line 45 of the computer *04 = 1dEF => The value is incoherent</p>
--	--

NOTES	<p>If BG 3 LH side or BG 5 LH side or BG 6 RH side is also illuminated, check line 26 of the computer.</p>
--------------	--

<p>*04 = CC0 *04 = CO1</p>	<p>Connect the bornier in place of the computer and check the insulation, continuity and that there is no interference resistance on line:</p> <table style="margin-left: 20px;"> <tr> <td>Computer</td> <td style="padding: 0 10px;">45</td> <td style="text-align: center;">→</td> <td style="padding: 0 10px;">1</td> <td>Coolant temperature sensor</td> </tr> <tr> <td>Computer</td> <td style="padding: 0 10px;">26</td> <td style="text-align: center;">→</td> <td style="padding: 0 10px;">2</td> <td>Coolant temperature sensor</td> </tr> </table> <p>Repair if necessary.</p> <p>Check the resistance of the sensor. Replace it if necessary.</p> <p>The problem is still not resolved! The injection computer must therefore be replaced.</p> <p>IMPORTANT : The damage to the computer is probably due to an electrical shock. The cause of the damage must be found before a new computer is fitted.</p>	Computer	45	→	1	Coolant temperature sensor	Computer	26	→	2	Coolant temperature sensor
Computer	45	→	1	Coolant temperature sensor							
Computer	26	→	2	Coolant temperature sensor							

<p>*04 = 1 dEF</p>	<p>Connect the bornier in place of the computer and check the insulation and that there is no interference resistance on line:</p> <table style="margin-left: 20px;"> <tr> <td>Computer</td> <td style="padding: 0 10px;">45</td> <td style="text-align: center;">→</td> <td style="padding: 0 10px;">1</td> <td>Coolant temperature sensor</td> </tr> <tr> <td>Computer</td> <td style="padding: 0 10px;">26</td> <td style="text-align: center;">→</td> <td style="padding: 0 10px;">2</td> <td>Coolant temperature sensor</td> </tr> </table> <p>Note: The signal reaches the computer, but the value given is not correct (interference).</p> <p>Repair if necessary.</p> <p>Replace the sensor as it is partly faulty.</p> <p>The problem is still not resolved! The injection computer must therefore be replaced.</p> <p>IMPORTANT : The damage to the computer is probably due to an electrical shock. The cause of the damage must be found before a new computer is fitted.</p>	Computer	45	→	1	Coolant temperature sensor	Computer	26	→	2	Coolant temperature sensor
Computer	45	→	1	Coolant temperature sensor							
Computer	26	→	2	Coolant temperature sensor							

AFTER REPAIR	<p>Erase the computer memory using GO**.</p> <p>Try to start the vehicle. Switch on the ignition, then deal with the other faults.</p> <p>Remember to carry out a status and parameter check!</p>
---------------------	---

Fault finding - Interpretation of XR25 bargraphs

<p style="margin: 0;">4</p> 	<p>Bargraph 4 RH side illuminated Fiche n° 47 side 1/2</p> <p><u>VEHICLE SPEED SENSOR CIRCUIT</u></p> <p>XR25 aid: CO, CC- or CC+ line 9</p>
--	---

NOTES	<p>If BG 4 RH side is flashing, carry out a road test. If BG 4 RH side has become fixed, deal with the fault.</p>
--------------	---

<p>Connect the bornier in place of the computer and check the insulation, continuity and that there is no interference resistance on line:</p> <p style="text-align: center;">Computer 9 \longrightarrow 3 Vehicle speed sensor</p> <p>Repair if necessary.</p>
<p>Check, on the vehicle speed sensor, for the presence of:</p> <ul style="list-style-type: none"> - earth on track 2, - + 12 after ignition feed on track 1. <p>Repair if necessary.</p>
<p>Check that the sensor is correctly positioned.</p>
<p>The fault persists. Replace the sensor.</p>
<p>The problem is still not resolved! The injection computer must therefore be replaced.</p> <p>IMPORTANT : The damage to the computer is probably due to an electrical shock. The cause of the damage must be found before a new computer is fitted.</p>

AFTER REPAIR	<p>Erase the computer memory using GO**.</p> <p>Try to start the vehicle. Switch on the ignition, then deal with the other faults.</p> <p>Remember to carry out a status and parameter check!</p>
---------------------	---

Fault finding - Interpretation of XR25 bargraphs

<div style="border: 1px solid black; padding: 5px; width: 60px; margin: 0 auto;"> <p style="text-align: center; margin: 0;">5</p>  </div>	<p>Bargraph 5 LH side illuminated Fiche n° 47 side 1/2</p> <p><u>MANIFOLD PRESSURE SENSOR CIRCUIT</u></p> <p>XR25 aid: *05 = 1dEF => The value is incoherent *05 = 2dEF => The sensor information is outside tolerance values</p>
---	---

NOTES	<p>If BG 3 LH side or BG 4 LH side or BG 6 RH side is also illuminated, check line 26 of the computer.</p> <p>If BG 6 RH side is also illuminated, check line 12 of the computer.</p>
--------------	---

<p>*05 = 1 dEF *05 = 2 dEF</p>	<p>Connect the bornier in place of the computer and check the insulation and that there is no interference resistance on line:</p> <table style="margin-left: 20px;"> <tr> <td>Computer</td> <td style="padding: 0 10px;">7</td> <td style="text-align: center;">→</td> <td style="padding: 0 10px;">1</td> <td>Pressure sensor</td> </tr> <tr> <td>Computer</td> <td style="padding: 0 10px;">12</td> <td style="text-align: center;">→</td> <td style="padding: 0 10px;">3</td> <td>Pressure sensor</td> </tr> <tr> <td>Computer</td> <td style="padding: 0 10px;">26</td> <td style="text-align: center;">→</td> <td style="padding: 0 10px;">2</td> <td>Pressure sensor</td> </tr> </table> <p>Note: If *05 = 1dEF, the signal reaches the computer, but the value given is not correct (interference). Repair if necessary.</p>	Computer	7	→	1	Pressure sensor	Computer	12	→	3	Pressure sensor	Computer	26	→	2	Pressure sensor
Computer	7	→	1	Pressure sensor												
Computer	12	→	3	Pressure sensor												
Computer	26	→	2	Pressure sensor												
	<p>Replace the sensor as it is partly faulty.</p>															
	<p>The problem is still not resolved! The injection computer must therefore be replaced.</p> <p>IMPORTANT : The damage to the computer is probably due to an electrical shock. The cause of the damage must be found before a new computer is fitted.</p>															

AFTER REPAIR	<p>Erase the computer memory using GO**.</p> <p>Try to start the vehicle. Switch on the ignition, then deal with the other faults.</p> <p>Remember to carry out a status and parameter check!</p>
---------------------	---

Fault finding - Interpretation of XR25 bargraphs

<div style="border: 1px solid black; padding: 5px; width: 40px; margin: 0 auto;">5</div>	<p>Bargraph 5 RH side illuminated Fiche n° 47 side 1/2</p> <p><u>FLYWHEEL SIGNAL CIRCUIT</u></p> <p>XR25 aid: *25 = 1 dEF => Starter motor activated, the computer does not detect the target teeth</p> <p> *25 = 2 dEF => Engine running, the computer does not count the number of teeth correctly</p>
--	---

NOTES	<p>If BG 5 RH side is flashing, carry out a test at starter motor speed. If the engine starts, carry out a test with the engine running (5 minutes). If BG 5 RH side has become fixed, deal with the fault. If other bargraphs are illuminated, check the cleanliness of the vehicle earth.</p>
--------------	---

*25 = 1 dEF	<p>Check the condition of the flywheel, especially if it has been removed. Repair if necessary.</p>															
	<p>Check for earth on track 3 of the sensor. Repair if necessary.</p>															
	<p>Connect the bornier in place of the computer and check the insulation, continuity and that there is no interference resistance on line:</p> <table style="margin-left: 40px; border: none;"> <tr> <td style="padding-right: 10px;">Computer</td> <td style="padding-right: 10px;">24</td> <td style="padding-right: 10px;">→</td> <td style="padding-right: 10px;">3</td> <td style="padding-right: 10px;">Target sensor</td> </tr> <tr> <td>Computer</td> <td>48</td> <td>→</td> <td>2</td> <td>Target sensor</td> </tr> <tr> <td>Computer</td> <td>49</td> <td>→</td> <td>1</td> <td>Target sensor</td> </tr> </table> <p>Repair if necessary.</p>	Computer	24	→	3	Target sensor	Computer	48	→	2	Target sensor	Computer	49	→	1	Target sensor
Computer	24	→	3	Target sensor												
Computer	48	→	2	Target sensor												
Computer	49	→	1	Target sensor												
	<p>The fault persists! Replace the sensor.</p>															
	<p>The problem is still not resolved! The injection computer must therefore be replaced.</p> <p>IMPORTANT : The damage to the computer is probably due to an electrical shock. The cause of the damage must be found before a new computer is fitted.</p>															

*25 = 2 dEF	<p>Check the condition of the flywheel. Check that the sensor is correctly positioned. Repair if necessary.</p>
	<p>Apply the fault finding for this fault for *25 = 1dEF</p>

AFTER REPAIR	<p>Erase the computer memory using GO**. Try to start the vehicle. Switch on the ignition, then deal with the other faults. Remember to carry out a status and parameter check!</p>
---------------------	---

Fault finding - Interpretation of XR25 bargraphs

<div style="border: 1px solid black; padding: 5px; margin: 0 auto; width: 80%;"> <p style="text-align: center; margin: 0;">6</p> </div>	<p>Bargraph 6 LH side illuminated Fiche n° 47 side 1/2</p> <p><u>PINKING SENSOR CIRCUIT</u></p> <p>XR25 aid: *06 = 1dEF => The sensor information is outside tolerance limits *06 = 2dEF => False pinking detection</p>
---	---

NOTES	<p>In the case of certain faults, BG 6 LH side can only be illuminated at 3000 rpm for 1 minute. If other bargraphs are illuminated, check the cleanliness of the vehicle earth.</p>
--------------	--

*06 = 1 dEF	<p>Check for earth on track 3 of the sensor. Repair if necessary.</p> <p>Connect the bornier in place of the computer and check the insulation, continuity and that there is no interference resistance on line:</p> <table style="margin-left: 40px;"> <tr> <td>Computer</td> <td>11</td> <td>→</td> <td>1</td> <td>Pinking sensor</td> </tr> <tr> <td>Computer</td> <td>14</td> <td>→</td> <td>3</td> <td>Pinking sensor</td> </tr> <tr> <td>Computer</td> <td>30</td> <td>→</td> <td>2</td> <td>Pinking sensor</td> </tr> </table> <p>Repair if necessary.</p> <p>The fault persists! Replace the pinking sensor.</p> <p>The problem is still not resolved! The injection computer must therefore be replaced.</p> <p>IMPORTANT : The damage to the computer is probably due to an electrical shock. The cause of the damage must be found before a new computer is fitted.</p>	Computer	11	→	1	Pinking sensor	Computer	14	→	3	Pinking sensor	Computer	30	→	2	Pinking sensor
Computer	11	→	1	Pinking sensor												
Computer	14	→	3	Pinking sensor												
Computer	30	→	2	Pinking sensor												

*06 = 2 dEF	<p>Check that the pinking sensor is correctly mounted. Repair if necessary.</p> <p>Check that the engine is not making an unusual noise. In the case of an unusual noise, the cause of this noise must be eliminated.</p> <p>Connect the bornier in place of the computer and check the insulation :</p> <table style="margin-left: 40px;"> <tr> <td>Computer</td> <td>11</td> <td>→</td> <td>1</td> <td>Pinking sensor</td> </tr> <tr> <td>Computer</td> <td>14</td> <td>→</td> <td>3</td> <td>Pinking sensor</td> </tr> <tr> <td>Computer</td> <td>30</td> <td>→</td> <td>2</td> <td>Pinking sensor</td> </tr> </table> <p>Repair if necessary.</p>	Computer	11	→	1	Pinking sensor	Computer	14	→	3	Pinking sensor	Computer	30	→	2	Pinking sensor
Computer	11	→	1	Pinking sensor												
Computer	14	→	3	Pinking sensor												
Computer	30	→	2	Pinking sensor												

AFTER REPAIR	<p>Erase the computer memory using GO**. Try to start the vehicle. Switch on the ignition, then deal with the other faults. Remember to carry out a status and parameter check!</p>
---------------------	---

Fault finding - Interpretation of XR25 bargraphs

<p style="margin: 0;">6</p> 	<p>Bargraph 6 RH side illuminated Fiche n° 47 side 1/2</p> <p><u>THROTTLE POTENTIOMETER CIRCUIT</u></p> <p>XR25 aid: CO, CC-, CC+ line 53, 12 or 26</p>
---	--

NOTES	<p>If BG 3 LH side or BG 4 LH side or BG 5 LH side is also illuminated, check line 26 of the computer.</p> <p>If BG 5 LH side is also illuminated, check line 12 of the computer.</p> <p>After the operation, enter the fault finding for automatic transmission to erase the AT computer fault.</p>
--------------	---

<p>Connect the bornier in place of the computer and check the insulation, continuity and that there is no interference resistance on line:</p>																
<table style="width: 100%; border: none;"> <tr> <td style="padding: 2px;">Computer</td> <td style="padding: 2px;">12</td> <td style="padding: 2px;">→</td> <td style="padding: 2px;">2</td> <td style="padding: 2px;">Throttle potentiometer</td> </tr> <tr> <td style="padding: 2px;">Computer</td> <td style="padding: 2px;">26</td> <td style="padding: 2px;">→</td> <td style="padding: 2px;">1</td> <td style="padding: 2px;">Throttle potentiometer</td> </tr> <tr> <td style="padding: 2px;">Computer</td> <td style="padding: 2px;">53</td> <td style="padding: 2px;">→</td> <td style="padding: 2px;">3</td> <td style="padding: 2px;">Throttle potentiometer</td> </tr> </table>	Computer	12	→	2	Throttle potentiometer	Computer	26	→	1	Throttle potentiometer	Computer	53	→	3	Throttle potentiometer	<p>Repair if necessary.</p>
Computer	12	→	2	Throttle potentiometer												
Computer	26	→	1	Throttle potentiometer												
Computer	53	→	3	Throttle potentiometer												
<p>Check the resistance of the sensor. Replace the throttle potentiometer if necessary.</p>																
<p>The problem is still not resolved! The injection computer must therefore be replaced.</p> <p>IMPORTANT : The damage to the computer is probably due to an electrical shock.</p> <p>The cause of the damage must be found before a new computer is fitted.</p>																

AFTER REPAIR	<p>Erase the computer memory using GO**.</p> <p>Try to start the vehicle. Switch on the ignition, then deal with the other faults.</p> <p>Remember to carry out a status and parameter check!</p>
---------------------	---

Fault finding - Interpretation of XR25 bargraphs

<p>7</p> 	<p>Bargraph 7 RH side illuminated Fiche n° 47 side 1/2</p> <p><u>PARK / NEUTRAL / TORQUE REDUCTION CIRCUIT</u></p> <p>XR25 aid: None</p>
---	---

NOTES	<p>This bargraph is not active.</p>
--------------	-------------------------------------

AFTER REPAIR	<p>Erase the computer memory using GO**.</p> <p>Try to start the vehicle. Switch on the ignition, then deal with the other faults.</p> <p>Remember to carry out a status and parameter check!</p>
---------------------	---

Fault finding - Interpretation of XR25 bargraphs

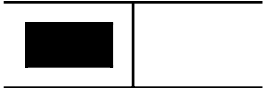
<div style="text-align: center; font-weight: bold; font-size: 18px;">8</div> 	<p>Bargraph 8 LH side illuminated Fiche n° 47 side 1/2</p> <p><u>FUEL PUMP CIRCUIT</u></p> <p>XR25 aid: *08 = CO => CO line 3 of the computer *08 = CC0 => CC- line 3 of the computer *08 = CC1 => CC+ line 3 of the computer</p>
---	---

NOTES	<p>If other bargraphs are illuminated, check for the presence of 12 volts on track 1 of the fuel pump relay. If other bargraphs are illuminated, check the cleanliness of the vehicle earth.</p>
-------	--

Fuel pump relay in place, check for + 12V between tracks 1 and 2, during the timed phase when the ignition is switched on.

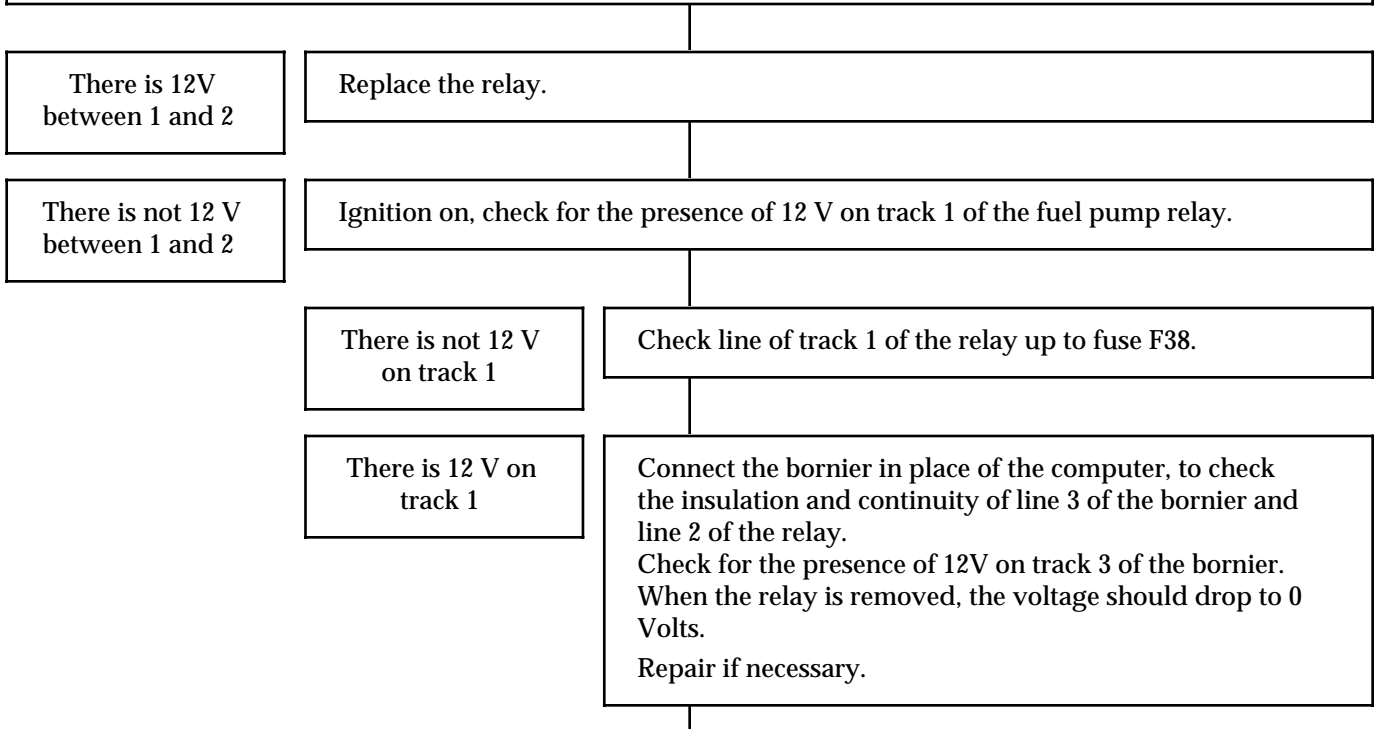

The problem is still not resolved! The injection computer must therefore be replaced.
IMPORTANT : The damage to the computer is probably due to an electrical shock.
 The cause of the damage must be found before a new computer is fitted.

AFTER REPAIR	<p>Erase the computer memory using GO**. Try to start the vehicle. Switch on the ignition, then deal with the other faults. Remember to carry out a status and parameter check!</p>
--------------	---

Fault finding - Interpretation of XR25 bargraphs

<p>10</p> 	<p>Bargraph 10 LH side illuminated Fiche n° 47 side 1/2</p> <p><u>FAULT WARNING LIGHT CIRCUIT</u></p> <p>XR25 aid: *10 = CO0 => CO, or CC- line 15 of the computer *10 = CC1 => CC+ line 15 of the computer</p>
---	---

NOTES	<p>For a CC+, the fault can only be detected during the warning light command phase.</p>
--------------	--

<p>If the fault warning light does not illuminate, ensure that the bulb has not blown.</p>
<p>Check the control line for the warning light in question. Connect the bornier in place of the computer and the bornier in place of the instrument panel and check the insulation and continuity of the line:</p> <p style="text-align: center;">Computer 15 \longrightarrow 9 Fault warning light (15 track connector)</p> <p>Repair if necessary.</p>
<p>Check the 12 V on the instrument panel bornier. Repair if necessary.</p>
<p>The problem is still not resolved! The injection computer must therefore be replaced. IMPORTANT : The damage to the computer is probably due to an electrical shock. The cause of the damage must be found before a new computer is fitted.</p>

AFTER REPAIR	<p>Erase the computer memory using GO**. Try to start the vehicle. Switch on the ignition, then deal with the other faults. Remember to carry out a status and parameter check!</p>
---------------------	---

Fault finding - Interpretation of XR25 bargraphs

<p>11</p> 	<p>Bargraph 11 LH side illuminated Fiche n° 47 side 1/2</p> <p><u>CANISTER BLEED VALVE CIRCUIT</u></p> <p>XR25 aid: *11 = CO => CO line 5 of the computer *11 = CC0 => CC- line 5 of the computer *11 = CC1 => CC+ line 5 of the computer</p>
---	---

NOTES	If other bargraphs are also illuminated, check line 36 of the computer.
--------------	---

<p>Connect the bornier in place of the computer and check the insulation and continuity of the line:</p> <table style="margin-left: 40px;"> <tr> <td>Computer</td> <td style="text-align: center;">5</td> <td style="text-align: center;">→</td> <td style="text-align: center;">2</td> <td>Canister bleed valve</td> </tr> <tr> <td>Computer</td> <td style="text-align: center;">36</td> <td style="text-align: center;">→</td> <td style="text-align: center;">2</td> <td>Main relay</td> </tr> </table> <p>Repair if necessary.</p>	Computer	5	→	2	Canister bleed valve	Computer	36	→	2	Main relay
Computer	5	→	2	Canister bleed valve						
Computer	36	→	2	Main relay						
<p>With the ignition switched on, check for the presence of 12 V on track 1 of the canister bleed valve. Repair the wiring from track 1 of the canister bleed valve to track 3 of the main relay.</p>										
<p>Check the resistance of the canister bleed valve. Replace the valve if necessary.</p>										
<p>The problem is still not resolved! The injection computer must be replaced. IMPORTANT: The damage to the computer is probably due to an electrical shock. The cause of the damage must be found before a new computer is fitted.</p>										

AFTER REPAIR	<p>Erase the computer memory using GO**. Try to start the vehicle. Switch on the ignition, then deal with the other faults. Remember to carry out a status and parameter check!</p>
---------------------	---

Fault finding - Interpretation of XR25 bargraphs

11 or 12 or 13 <div style="border: 1px solid black; width: 40px; height: 20px; background-color: black; margin: 0 auto;"></div>	<p>Bargraphs 11 or 12 or 13 RH side illuminated Fiche n° 47 side 1/2</p> <p><u>INJECTOR CIRCUIT GROUP A or B or C</u></p> <p>XR25 aid: *31 or 32 or 33 = CO => CO line 17 or 16 or 35 *31 or 32 or 33 = CC0 => CC- line 17 or 16 or 35 *31 or 32 or 33 = CC1 => CC +line 17 or 16 or 35</p>
---	---

NOTES	<p>Injection A = Injectors 1.5 BG 11 RH side *31 line 17 Injection B = Injectors 2.6 BG 12 RH side *32 line 35 Injection C = Injectors 3.4 BG 13 RH side *33 line 16 Fault finding must be carried out while the engine is running.</p>
--------------	--

<p>With the ignition switched on, check for the presence of 12 V on track 1 of the injectors concerned. Repair, if necessary, the wiring from track 1 of the injector to track 3 of the main relay.</p>															
<p>Connect the bornier in place of the computer and check the insulation and continuity of the line:</p> <table style="margin-left: 20px;"> <tr> <td>Injection A : Computer</td> <td>17</td> <td>→</td> <td>1</td> <td>Injectors</td> </tr> <tr> <td>Injection B : Computer</td> <td>35</td> <td>→</td> <td>1</td> <td>Injectors</td> </tr> <tr> <td>Injection C : Computer</td> <td>16</td> <td>→</td> <td>1</td> <td>Injectors</td> </tr> </table> <p>Repair if necessary.</p>	Injection A : Computer	17	→	1	Injectors	Injection B : Computer	35	→	1	Injectors	Injection C : Computer	16	→	1	Injectors
Injection A : Computer	17	→	1	Injectors											
Injection B : Computer	35	→	1	Injectors											
Injection C : Computer	16	→	1	Injectors											
<p>Check the resistance of the injectors. Replace the injector(s) if necessary.</p>															
<p>The problem is still not resolved! The injection computer must be replaced. IMPORTANT: The damage to the computer is probably due to an electrical shock. The cause of the damage must be found before a new computer is fitted.</p>															

AFTER REPAIR	<p>Erase the computer memory using GO**. Try to start the vehicle. Switch on the ignition, then deal with the other faults. Remember to carry out a status and parameter check!</p>
---------------------	---

Fault finding - Interpretation of XR25 bargraphs

<p>13</p> 	<p>Bargraph 13 LH side illuminated Fiche n° 47 side 1/2</p> <p><u>ADAPTIVE IDLE SPEED</u></p> <p>XR25 aid: The values (# 12 or # 21) are outside the tolerance limits</p>
---	--

NOTES	This fault is not due to an electrical problem.
--------------	---

# 12 too high or # 21 too high or # 06 too low	NOTES	The idle speed is too low
--	--------------	---------------------------

<p>The idle speed regulation is not sufficient to maintain the idle speed.</p> <ul style="list-style-type: none"> - Clean the air supply circuit (idle speed regulation valve) as it is probably contaminated. - Check the engine oil level (too high => splashing). - Check and ensure the correct fuel pressure. - Use the OPTIMA 5800 station to check engine compressions. - Check valve clearances and the setting of the timing. <p>If all these points are correct, replace the idle speed regulation valve.</p>

# 12 too low or # 21 too low or # 06 too high	NOTES	The idle speed is too high
---	--------------	----------------------------

<p>An air leak may disrupt the idle speed regulation programming.</p> <ul style="list-style-type: none"> - Check the manifold connections. - Check the cleanliness of the pipes connected to the manifold. - Check the pneumatically controlled solenoid valves. - Check the manifold gaskets. - Check the sealing of the brake servo. - Check for the restrictions in the oil vapour rebreathing circuit. - Check the fuel pressure. <p>If all these points are correct, replace the idle speed regulation valve.</p>

AFTER REPAIR	<p>Erase the computer memory using GO**.</p> <p>Try to start the vehicle. Switch on the ignition, then deal with the other faults.</p> <p>Remember to carry out a status and parameter check!</p>
---------------------	---

Fault finding - Interpretation of XR25 bargraphs

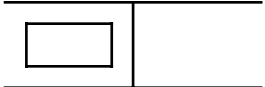
<p style="text-align: center;">14</p> 	<p>Bargraph 14 LH side Fiche n° 47 side 1/2</p> <p><u>INJECTION ---> ELECTRIC WINDSCREEN CONNECTION</u></p> <p>XR25 aid: None</p>
<p style="text-align: center;">NOTES</p>	<p>This bargraph is not active.</p>

<p style="text-align: center;">AFTER REPAIR</p>	<p>Erase the computer memory using GO**.</p> <p>Try to start the vehicle. Switch on the ignition, then deal with the other faults.</p> <p>Remember to carry out a status and parameter check!</p>
--	---

Fault finding - Interpretation of XR25 bargraphs

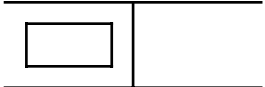
<p>15</p> 	<p>Bargraph 15 LH side Fiche n° 47 side 1/2</p> <p><u>INJECTION ---> AIR CONDITIONING CIRCUIT</u></p>
---	--

NOTES	<p>This bargraph is not active.</p> <p>To check the line, use bornier Elé.1391 for the AC control and bornier Elé 1444 for the computer.</p>
--------------	--

Connect the bornier in place of the computer and check the insulation and continuity of the line:

Computer 23 \longrightarrow AC panel

Repair if necessary.

The fault persists! Consult AC fault finding.

AFTER REPAIR	<p>Erase the computer memory using GO**.</p> <p>Try to start the vehicle. Switch on the ignition, then deal with the other faults.</p> <p>Remember to carry out a status and parameter check!</p>
---------------------	---

Fault finding - Interpretation of XR25 bargraphs

<p style="margin: 0;">16</p> 	<p>Bargraph 16 LH side illuminated Fiche n° 47 side 1/2</p> <p><u>IGNITION COIL CIRCUIT</u></p> <p>XR25 aid: *16 = X.CO0 => CO or CC-line 1, 20 or 21 *16 = X.CC1 => CC+ line 1, 20 or 21</p>
--	---

NOTES	<p>If X = 1 => Line 1 of the computer, control for plugs 1 and 5 If X = 2 => Line 20 of the computer, control for plugs 2 and 6 If X = 3 => Line 21 of the computer, control for plugs 3 and 4 If other bargraphs are illuminated, check the cleanliness of the vehicle earth</p>
--------------	---

<p>If the engine does not start, consult the fault finding for BG 16 LH side CONT 1.</p>															
<p>If the engine starts, carry out this fault finding. Connect the bornier in place of the computer and check the insulation and continuity of the line:</p> <table style="margin-left: 20px; border: none;"> <tr> <td style="padding-right: 10px;">If X = 1 => Line 1</td> <td style="padding-right: 10px;">of the computer</td> <td style="padding-right: 10px;">—————></td> <td style="padding-right: 10px;">1</td> <td>Coil</td> </tr> <tr> <td style="padding-right: 10px;">If X = 2 => Line 20</td> <td style="padding-right: 10px;">of the computer</td> <td style="padding-right: 10px;">—————></td> <td style="padding-right: 10px;">2</td> <td>Coil</td> </tr> <tr> <td style="padding-right: 10px;">If X = 3 => Line 21</td> <td style="padding-right: 10px;">of the computer</td> <td style="padding-right: 10px;">—————></td> <td style="padding-right: 10px;">3</td> <td>Coil</td> </tr> </table> <p>Repair if necessary.</p>	If X = 1 => Line 1	of the computer	—————>	1	Coil	If X = 2 => Line 20	of the computer	—————>	2	Coil	If X = 3 => Line 21	of the computer	—————>	3	Coil
If X = 1 => Line 1	of the computer	—————>	1	Coil											
If X = 2 => Line 20	of the computer	—————>	2	Coil											
If X = 3 => Line 21	of the computer	—————>	3	Coil											
<p>Check the resistance of the coil. Replace the coil if necessary.</p>															
<p>The problem is still not resolved! The injection computer must be replaced. IMPORTANT: The damage to the computer is probably due to an electrical shock. The cause of the damage must be found before a new computer is fitted.</p>															

AFTER REPAIR	<p>Erase the computer memory using GO**. Try to start the vehicle. Switch on the ignition, then deal with the other faults. Remember to carry out a status and parameter check!</p>
---------------------	---

Fault finding - Interpretation of XR25 bargraphs

<p>16</p> <div style="border: 1px solid black; width: 50px; height: 20px; background-color: black; margin: 0 auto;"></div> <p style="text-align: center;">CONT 1</p>	<p>Bargraph 16 LH side illuminated Fiche n° 47 side 1/2</p> <p><u>IGNITION CIRCUIT</u></p> <p>XR25 aid: None.</p>
---	--

NOTES	This fault finding operation must be carried out ONLY if the engine does not start.
--------------	--

Enter the fuel pump control mode (G10*).

If the fuel pump operates	<p>Check the insulation and continuity of the line:</p> <p style="text-align: center;">Coil 4 \longrightarrow 5 Ignition relay</p> <p>Repair if necessary.</p>
	Check for earth on track 2 of the ignition relay. Repair the electrical line, if necessary.
	With the ignition switched on, check for the presence of 12 V on track 5 of the ignition relay. Repair the electrical line, if necessary, remembering the 30A fuse F49.
	During the timed phase when the ignition is switched on, check for the presence of 12 V on track 1 of the ignition relay. Repair, if necessary, electrical line 1 from the ignition relay to fuel pump relay 5.
	If the fault persists, replace the ignition relay.

If the fuel pump does not operate	Consult fault finding BG 16 LH side CONT 2.
-----------------------------------	---

AFTER REPAIR	<p>Erase the computer memory using GO**.</p> <p>Try to start the vehicle. Switch on the ignition, then deal with the other faults.</p> <p>Remember to carry out a status and parameter check!</p>
---------------------	---

Fault finding - Interpretation of XR25 bargraphs

<p>16</p>  <p style="text-align: center;">CONT 2</p>	
---	--

<p>The fuel pump does not operate</p>	<p>With the ignition switched on, check for the presence of 12 V on track 3 of the fuel pump relay. Repair the electrical line, if necessary, remembering the F49 30A fuse.</p>															
	<p>During the timed phase when the ignition is switched on, check for the presence of 12 V on track 5 of the fuel pump relay.</p>															
	<p>If there is not 12 V on track 5 of the fuel pump relay, the relay is faulty or check the impact sensor. Replace the relay.</p>															
	<p>If there is 12 V on track 5 of the fuel pump relay, check the resistance of the fuel pump. Replace the fuel pump if necessary.</p>															
	<p>Check the insulation and continuity of the line:</p> <table style="margin-left: 40px; border: none;"> <tr> <td style="padding-right: 20px;">Fuel pump relay</td> <td style="padding-right: 10px;">5</td> <td style="text-align: center;">→</td> <td style="padding-right: 10px;">1</td> <td>Fuel pump</td> </tr> <tr> <td></td> <td></td> <td></td> <td></td> <td>(via the impact sensor)</td> </tr> <tr> <td style="padding-right: 20px;">Fuel pump relay</td> <td style="padding-right: 10px;">5</td> <td style="text-align: center;">→</td> <td style="padding-right: 10px;">1</td> <td>Ignition relay</td> </tr> </table> <p>Repair.</p>	Fuel pump relay	5	→	1	Fuel pump					(via the impact sensor)	Fuel pump relay	5	→	1	Ignition relay
Fuel pump relay	5	→	1	Fuel pump												
				(via the impact sensor)												
Fuel pump relay	5	→	1	Ignition relay												
	<p>If the pump still does not operate, check that earth is reaching the fuel pump. Repair.</p>															

<p>AFTER REPAIR</p>	<p>Erase the computer memory using GO**. Try to start the vehicle. Switch on the ignition, then deal with the other faults. Remember to carry out a status and parameter check!</p>
----------------------------	---

Fault finding - Interpretation of XR25 bargraphs

<p style="font-weight: bold; font-size: 1.2em;">18</p> 	<p>Bargraph 18 LH side illuminated Fiche n° 47 side 1/2</p> <p><u>OXYGEN SENSOR HEATING CIRCUIT</u></p> <p>XR25 aid: *18 = CO => CO line 51 of the computer *18 = CC0 => CC- line 51 of the computer *18 = CC1 => CC+ line 51 of the computer</p>
---	--

NOTES	<p>If other bargraphs are illuminated, check for the presence of 12 volts on track 1 of the oxygen sensor relay. This fault can be shown by a fixed bargraph while the engine is running.</p>
-------	---

Oxygen sensor relay in place, check, directly after the starting phase, for the presence of 12 V between tracks 1 and 2.

<p>There is 12 V between 1 and 2</p>	<p>Replace the relay.</p>
--------------------------------------	---------------------------

<p>There is not 12 V between 1 and 2</p>	<p>With the ignition switched on, check for the presence of 12 V on track 1 of the oxygen sensor relay.</p>
--	---

<p>There is not 12 V on track 1</p>	<p>Check the line of track 1 of the oxygen sensor relay up to track 87 of the fuel pump relay.</p>
-------------------------------------	--

<p>There is 12 V on track 1</p>	<p>Connect the bornier in place of the computer and check the insulation and continuity of the line: Bornier 51 → 2 Relay Repair.</p>
---------------------------------	---

The problem is still not resolved! The injection computer must be replaced.
**IMPORTANT: The damage to the computer is probably due to an electrical shock.
 The cause of the damage must be found before a new computer is fitted.**

AFTER REPAIR	<p>Erase the computer memory using GO**. Try to start the vehicle. Switch on the ignition, then deal with the other faults. Remember to carry out a status and parameter check!</p>
--------------	---

Fault finding - Interpretation of XR25 bargraphs

<p>18</p> <hr/> <div style="border: 1px solid black; width: 20px; height: 20px; background-color: black; margin: 0 auto;"></div>	<p>Bargraph 18 RH side illuminated Fiche n° 47 side 1/2</p> <p><u>REVERSE GEAR CIRCUIT</u></p> <p>XR25 aid: None.</p>
---	--

NOTES	<p>This bargraph is not active. Disregard this information.</p>
--------------	---

AFTER REPAIR	<p>Erase the computer memory using GO**.</p> <p>Try to start the vehicle. Switch on the ignition, then deal with the other faults.</p> <p>Remember to carry out a status and parameter check!</p>
---------------------	---

Fault finding - Interpretation of XR25 bargraphs

<p>19</p> 	<p style="text-align: right;">Fiche n° 47 side 1/2</p> <p>Bargraph 19 LH side illuminated</p> <p><u>IDLE SPEED REGULATION VALVE OPENING COMMAND CIRCUIT</u></p> <p>XR25 aid: *19 = CO => CO line 4 of the computer *19 = CC0 => CC- line 4 of the computer *19 = CC1 => CC+ line 4 of the computer</p>
---	---

NOTES	If other bargraphs are also illuminated, check line 36 of the computer.
--------------	---

<p>With the ignition switched on, check for the presence of 12 V on track 2 of the idle speed regulation valve. Repair, if necessary, the wiring from track 2 of the idle speed regulation valve to track 3 of the injection relay.</p>
<p>Check the resistance of the idle speed regulation solenoid valve. Replace the idle speed regulation valve if necessary.</p>
<p>Check the insulation and continuity of the line:</p> <p style="padding-left: 40px;">Idle speed regulation valve 3 \longrightarrow 4 Computer</p> <p>Repair if necessary.</p>
<p>The problem is still not resolved! The injection computer must be replaced.</p> <p>IMPORTANT: The damage to the computer is probably due to an electrical shock. The cause of the damage must be found before a new computer is fitted.</p>

AFTER REPAIR	<p>Erase the computer memory using GO**. Try to start the vehicle. Switch on the ignition, then deal with the other faults. Remember to carry out a status and parameter check!</p>
---------------------	---

Fault finding - Interpretation of XR25 bargraphs

<div style="border: 1px solid black; padding: 5px; width: 40px; margin: 0 auto;">19</div> <div style="border: 1px solid black; width: 60px; height: 30px; margin: 5px auto; background-color: black;"></div>	<p>Bargraph 19 RH side illuminated Fiche n° 47 side 1/2</p> <p><u>IDLE SPEED REGULATION VALVE CLOSING COMMAND CIRCUIT</u></p> <p>XR25 aid: *39 = CO => CO line 22 of the computer *39 = CC0 => CC- line 22 of the computer *39 = CC1 => CC+ line 22 of the computer</p>
--	---

NOTES	If other bargraphs are also illuminated, check line 36 of the computer.
--------------	---

<p>With the ignition switched on, check for the presence of 12 V on tracks 3 and 1 of the main relay. Repair if necessary.</p>
<p>Check the resistance of the idle speed regulation solenoid valve. Replace the the idle speed regulation valve if necessary.</p>
<p>Check the insulation and continuity of the line:</p> <p style="padding-left: 40px;">Idle speed regulation valve 1 \longrightarrow 22 Computer</p> <p>Repair if necessary.</p>
<p>The problem is still not resolved! The injection computer must be replaced.</p> <p>IMPORTANT: The damage to the computer is probably due to an electrical shock. The cause of the damage must be found before a new computer is fitted.</p>

AFTER REPAIR	<p>Erase the computer memory using GO**.</p> <p>Try to start the vehicle. Switch on the ignition, then deal with the other faults.</p> <p>Remember to carry out a status and parameter check!</p>
---------------------	---

Fault finding - Interpretation of XR25 bargraphs

<p>20</p> 	<p>Bargraph 20 LH side illuminated Fiche n° 47 side 1/2</p> <p><u>COMPUTER VOLTAGE</u></p> <p>XR25 aid: *20 = 1dEF => Supply voltage incoherent *20 = 2dEF => Supply voltage too high or too low</p>
---	--

NOTES	<p>If other bargraphs are also illuminated, check line 36 of the computer.</p>
--------------	--







*20 = 1 dEF	<p>The computer is no longer able to determine correct battery voltage. The computer must be replaced.</p>
-------------	--

*20 = 2 dEF	<p>Check the computer feed lines:</p> <ul style="list-style-type: none"> - computer track 18 - computer track 27 - computer track 37 <p>Check the battery and its charge. Check the charge circuit. Check the alternator regulator.</p>
-------------	--

AFTER REPAIR	<p>Erase the computer memory using GO**. Try to start the vehicle. Switch on the ignition, then deal with the other faults. Remember to carry out a status and parameter check!</p>
---------------------	---

Fault finding - Status and parameter check

NOTES	Engine stopped, ignition on
--------------	-----------------------------

Order of operations	Function to be checked	Action	Bargraph	Display and notes	Fault finding
1	XR25 Dialogue	D13 (selector S8)	<p style="text-align: center;">1</p>  <p style="text-align: center;">1</p> 	Fault test <div style="border: 1px solid black; padding: 2px; display: inline-block; margin: 5px;">11.NJ</div> Use fiche n° 47 fault side Code present	Deal with the fault bargraph
2	Change to status check	G01*	<p style="text-align: center;">1</p> 	<div style="border: 1px solid black; padding: 2px; display: inline-block; margin: 5px;">12.NJ</div> Status test	None.
3	Computer configuration		<p style="text-align: center;">19</p>  <p style="text-align: center;">19</p> 	With AT With manual gearbox	See XR25 fiche "Reminder C" to configure the vehicle
4	Engine immobiliser	Activate the immobiliser Deactivate the immobiliser	<p style="text-align: center;">3</p>  <p style="text-align: center;">3</p> 	Illuminated if immobiliser is locked Extinguished if immobiliser is unlocked	Consult immobiliser fault finding

Fault finding - Status and parameter check

NOTES	Engine stopped, ignition on
--------------	-----------------------------

Order of operations	Function to be checked	Action	Bargraph	Display and notes	Fault finding
5	Automatic transmission selector lever	Move the gear selector lever	<div style="display: flex; justify-content: center; align-items: center;"> <div style="border-bottom: 1px solid black; padding: 2px 10px;">4</div> <div style="border-left: 1px solid black; border-right: 1px solid black; border-bottom: 1px solid black; width: 20px; height: 15px; margin: 0 5px;"></div> <div style="border-bottom: 1px solid black; padding: 2px 10px;"></div> </div>	Illuminated in Park and Neutral positions	Consult AT fault finding
6	Fan assembly	G27 *3*		Fan assembly operates	Use the wiring diagram for the fan assembly fault finding
7	AC if present	Select AC, then G12*		The compressor clutch clicks	Consult the AC fault finding





Fault finding - Status and parameter check

NOTES	Carry out the actions below if the engine does not start . Otherwise, refer to the following pages.
--------------	---

Order of operations	Function to be checked	Action	Bargraph	Display and notes	Fault finding
1	Fuel pump	G10*		The fuel pump operates	DIAG 1
2	Canister bleed	G16*		The canister bleed solenoid valve clicks	DIAG 2
3	Ignition	Connect the Optima Station		Starting test. Complete guide on Optima Station	Use the Optima 5800Station
4	Fuel pressure	Connect a pressure gauge to the gallery and activate the starter motor		The pressure gauge should indicate 2 ± 0.5 bars	Fuel pressure, see Workshop Repair Manual or section

Fault finding - Status and parameter check

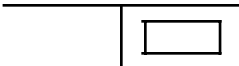
NOTES	Carry out the actions below if the engine starts . Otherwise, refer to the previous pages. Engine warm at idle speed, no consumers.
--------------	--

Order of operations	Function to be checked	Action	Bargraph	Display and notes	Fault finding
1	Power assisted steering pressostat	Turn the wheels to full lock	11 	Illuminated if the power assisted steering pressostat is operational	DIAG 3
2	AC	A.C.. selected	10  10  9 	Illuminated if the A.C. requests the operation of the compressor Extinguished if the injection authorises compressor operation Active fast idle speed	Consult the air conditioning fault finding
4	Ignition	Connect the Optima Station		Starting test. Complete guide on Optima Station.	Use the Optima 5800 Station
5	Compression	Connect the Optima Station		Complete guide on Optima Station.	Use the Optima 5800 Station

Fault finding - Status and parameter check

NOTES	Check with a road test
--------------	------------------------

Order of operations	Function to be checked	Action	Bargraph	Display and notes	Fault finding
1	Vehicle speed information	# 18		X = speed read on speedometer in km/h	DIAG 4
2	Torque reduction if A.T.		<p style="text-align: center;">13</p> 	Illuminated during changes in the A.T. gears	Consult AT fault finding
3	Emission of pollutants	<p style="text-align: center;">2500 rpm after driving</p> <p style="text-align: center;">At idle speed, wait for stabilisation</p>		<p>CO < 0.3 %</p> <p>CO₂ > 13.5 %</p> <p>O₂ < 0.8 %</p> <p>HC < 100 ppm</p> <p>0.97 < λ < 1.03</p> <p>CO < 0.5 %</p> <p>HC < 100 ppm</p> <p>0.97 < λ < 1.03</p>	<p>DIAG 5</p> <p>or use the Optima 5800 Station</p>

Fault finding - Status and Parameter Interpretation

DIAG 1	<div style="text-align: right; font-size: small;">Fiche n° 47 side 2/2</div> <p>FUEL PUMP</p> <p>XR25 aid: G10* = Fuel pump command, ignition on</p>
---------------	--

NOTES	No fault bargraph should be illuminated
--------------	---

Check that the impact sensor is correctly engaged.

Check the insulation and continuity of the wiring:

Fuel pump relay	5	→	Impact sensor
Impact sensor	1	→	2 Fuel pump

Repair if necessary.

Check the cleanliness and presence of earth on track 4 of the fuel pump.

Replace the fuel pump.

AFTER REPAIR	Repeat the status and parameter check from the beginning.
---------------------	---

Fault finding - Status and Parameter Interpretation

DIAG 2	<div style="text-align: right; font-size: small;">Fiche n° 47 side 2/2</div> <p>CANISTER BLEED</p> <p>XR25 aid: G16* = Canister bleed command</p>
---------------	---

NOTES	No fault bargraph should be illuminated
--------------	---

With the ignition switched on, check for the presence of 12 V on track 1 of the canister bleed solenoid valve.

Check the insulation and continuity of line 5 of the computer.

Repair.

Replace the canister bleed solenoid valve.

Note: When replacing the valve, shake it over a white sheet of paper, along with the adjacent piping.

If any particles of carbon fall, the canister will also have to be replaced.

AFTER REPAIR	Repeat the status and parameter check from the beginning.
---------------------	---

DIAG 3	<div style="text-align: right; font-size: small;">Fiche n° 47 side 2/2</div> <p>VEHICLE SPEED</p> <p>XR25 aid: # 18 = Speed read on speedometer in km/h</p>
---------------	---

NOTES	<p>No fault bargraph should be illuminated. Check with a road test.</p>
--------------	---

<p>If the value read is incoherent:</p> <ul style="list-style-type: none"> - Check that the sensor is correctly mounted. - Check that the sensor is correctly fed. - Check the insulation, continuity and that there is no resistance interference on the electrical line track 9 of the injection computer.
<p>The injection is no longer at fault. Check the various functions using this information.</p>

AFTER REPAIR	<p>Repeat the status and parameter check from the beginning.</p>
---------------------	--

Fault finding - Status and Parameter Interpretation

DIAG 4	<div style="text-align: right; font-size: small;">Fiche n° 47 side 2/2</div> <p>EMISSION OF POLLUTANTS</p> <p>XR25 aid: None.</p>
---------------	---

NOTES	No fault bargraph should be illuminated
--------------	---

$0.97 \leq \lambda \leq 1.03$ at 2500 rpm	NOTES	The oxygen sensor loops correctly at 2500 rpm
--	--------------	---

If $CO > 0.3\%$ to 2500 rpm

The catalytic converter is faulty. **Note:** The cause of the damage to the catalytic converter **MUST** be found to prevent damage to the new catalytic converter.

If $0.97 \leq \lambda \leq 1.03$ at idle speed. $CO > 0.3\%$ at 2500 rpm

The $CO > 0.5$ or $HC > 100$ ppm, indicates that the catalytic converter is too cold. It is de-primed, not faulty.

If $\lambda < 0.97$ or $\lambda > 1.03$ at idle speed

Check the earth and heating of the sensor.
Check that there are no air leaks in the manifold.

$0.97 \leq \lambda \leq 1.03$ at 2500 rpm	NOTES	The oxygen sensor does not loop correctly at 2500 rpm.
--	--------------	--

There is an injection or sensor fault.

AFTER REPAIR	Repeat the status and parameter check from the beginning.
---------------------	---

Fault finding - Status and Parameter Interpretation

DIAG 4 CONT	Fiche n° 47 side 2/2
---------------------------	----------------------

NOTES	No fault bargraph should be illuminated.
--------------	--

$\lambda > 1.03$ at 2500 rpm	NOTES	None.
---------------------------------	--------------	-------

The oxygen sensor loops correctly at 2500 rpm
Check that there are no leaks in the exhaust. Check that none of the injectors have seized. Check that the fuel flow is not too low.

The oxygen sensor does not loop correctly at 2500 rpm.
Check that there is not an injection fault. Check that there is not an ignition fault. Check that there is not a sensor fault. Check the fuel pressure.

$\lambda < 0.97$ at 2500 rpm	NOTES	The oxygen sensor does not loop correctly at 2500 rpm, CO > 0.3 % at 2500 rpm
---------------------------------	--------------	---

Check the pressure sensor. Check the sensor. Check that there are no faulty injectors.
--

AFTER REPAIR	Repeat the status and parameter check from the beginning.
---------------------	---

INJECTION

Fault finding - Customer complaints

17

NOTES

Only consult this customer complaint after a complete check using the XR25.

STARTING PROBLEMS — Chart 1

PROBLEMS AT IDLE SPEED — Chart 2

PROBLEMS WHILE DRIVING — Chart 3

Chart 1	STARTING PROBLEMS
----------------	--------------------------

NOTES	Only consult this customer complaint after a complete check using the XR25.
--------------	---

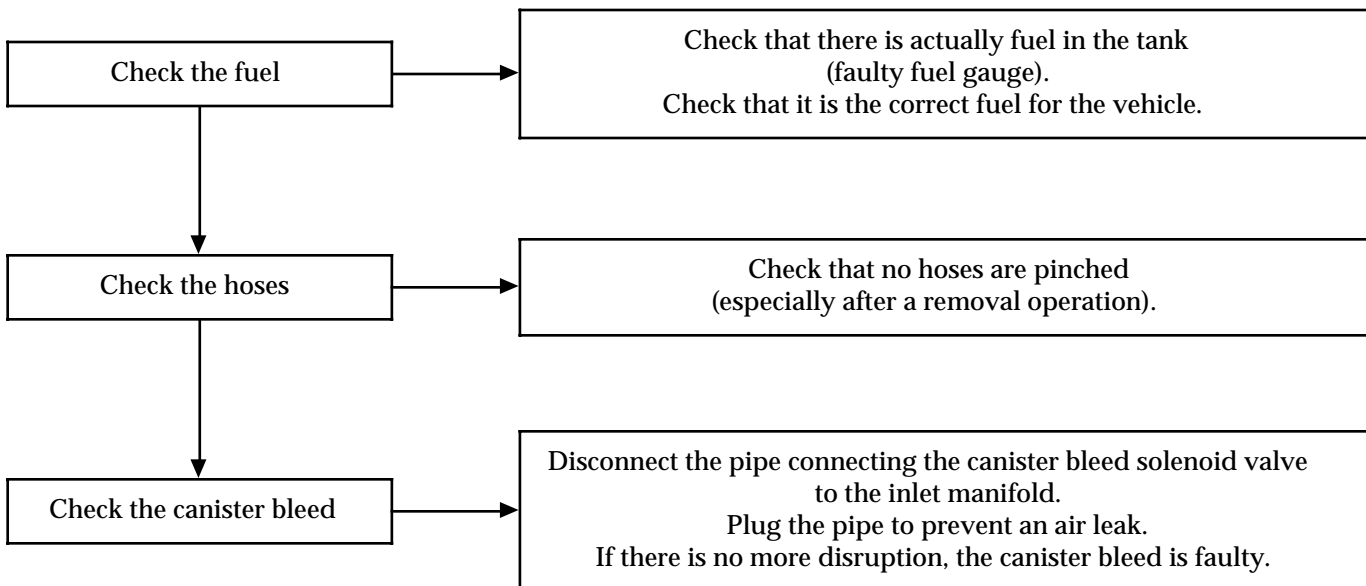

AFTER REPAIR	Repeat the status and parameter check from the beginning.
---------------------	---

Chart 2	IDLE SPEED FAULTS
----------------	--------------------------

NOTES	Only consult this customer complaint after a complete check using the XR25.
--------------	---

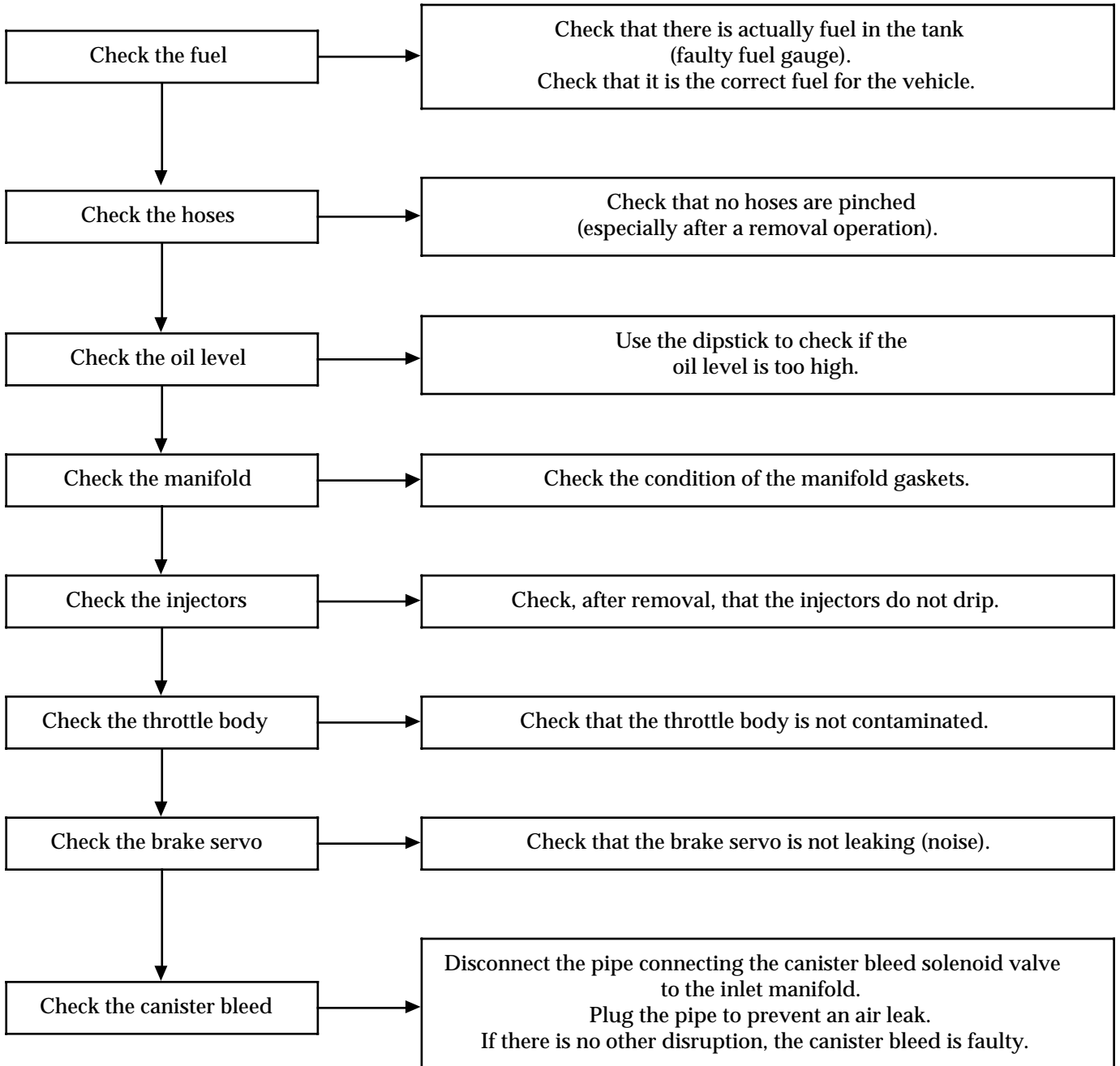

AFTER REPAIR	Repeat the status and parameter check from the beginning.
---------------------	---

Fault finding - Fault charts

Chart 3	PROBLEMS WHILE DRIVING
----------------	-------------------------------

NOTES	Only consult this customer complaint after a complete check using the XR25.
--------------	---

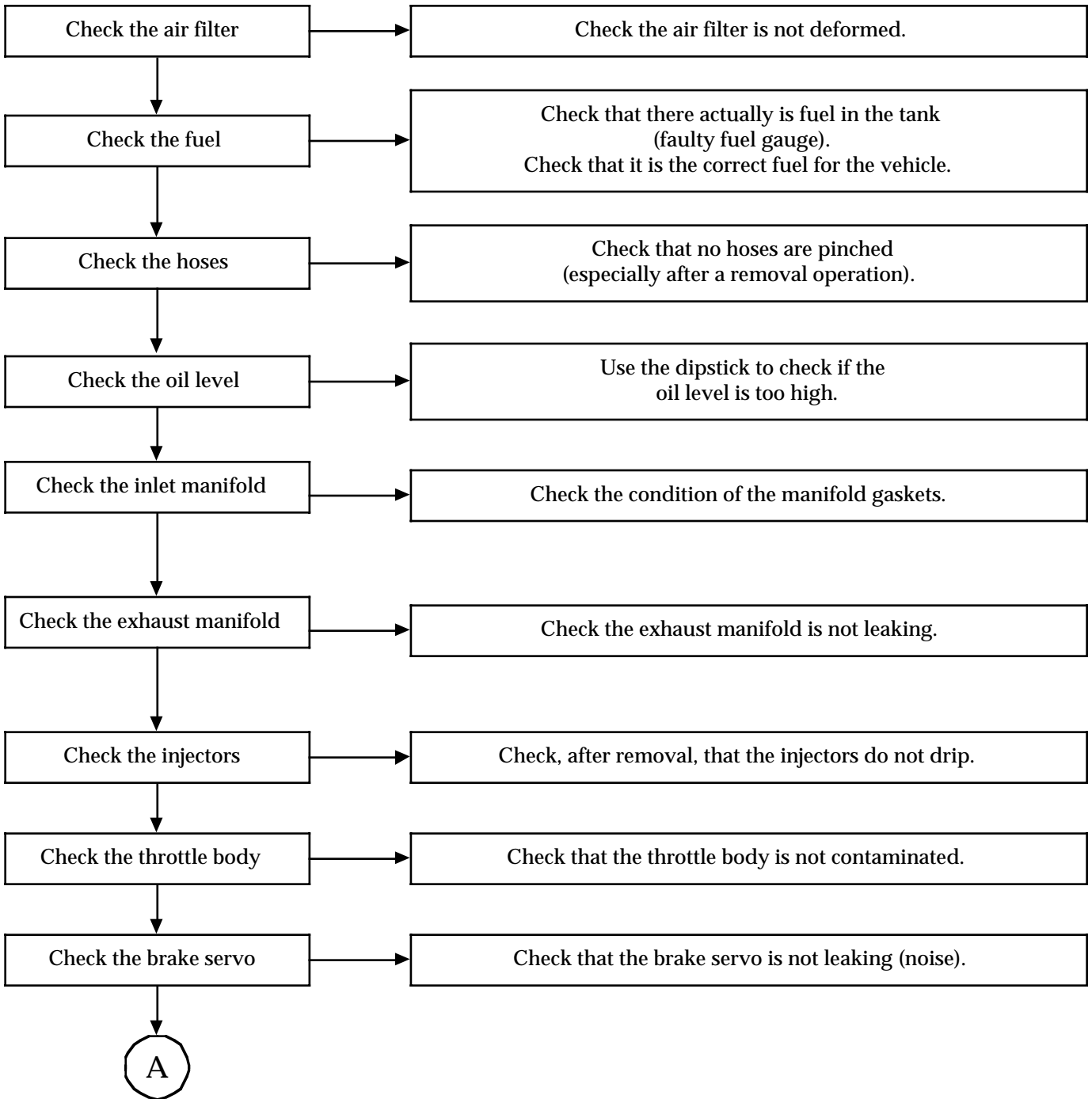

AFTER REPAIR	Repeat the status and parameter check from the beginning.
---------------------	---

Chart 3 CONT	
------------------------	--

NOTES	Only consult this customer complaint after a complete check using the XR25.
--------------	---

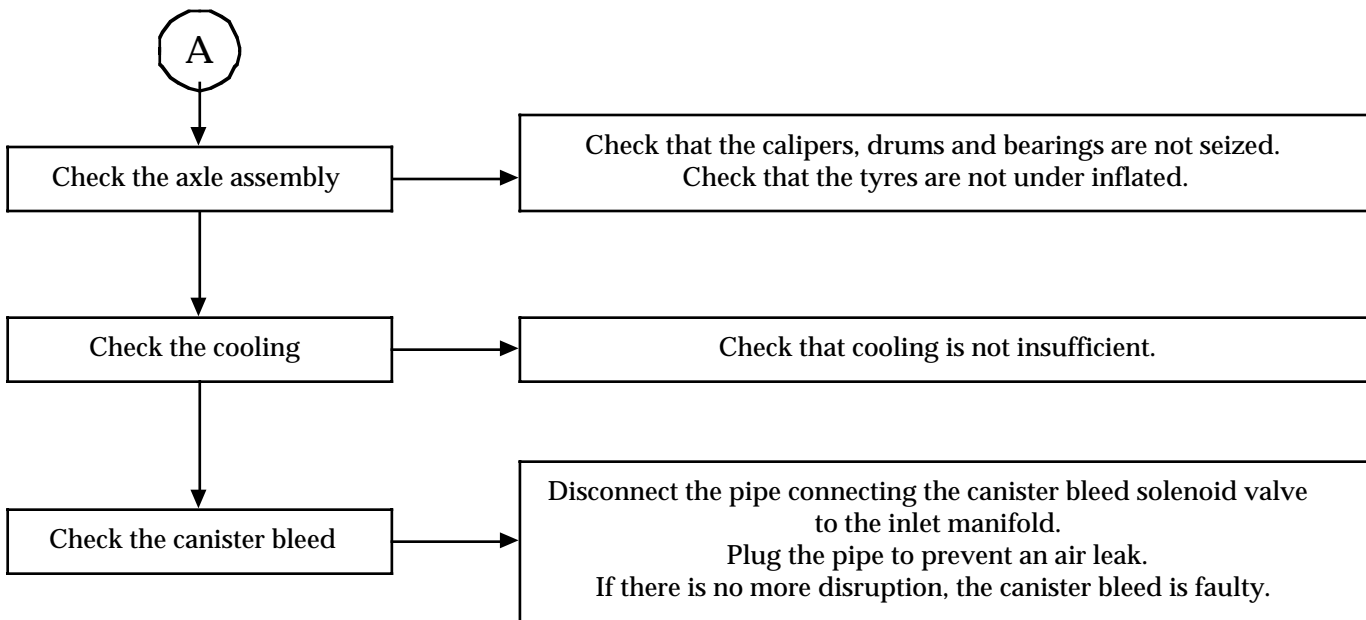

AFTER REPAIR	Repeat the status and parameter check from the beginning.
---------------------	---

INJECTION

Fault finding - Aid

17

Injector resistance	=	13 Ω
Idle speed regulation solenoid valve resistance	=	1 - 3 = 24 Ω 1 - 2 = 12 Ω 2 - 3 = 12 Ω
Canister bleed valve resistance	=	30 \pm 5 Ω
Ignition coil resistance	:	Primary = 1.1 Ω Secondary = 12.5 Ω
Oxygen sensor heating resistance	=	2 to 15 Ω
Throttle potentiometer resistance	:	No load 1 - 2 = 1930 Ω Full load 1 - 2 = 1930 Ω No load 1 - 3 = 1130 Ω Full load 1 - 3 = 2680 Ω No load 2 - 3 = 2515 Ω Full load 2 - 3 = 970 Ω
Flywheel signal sensor	=	375 Ω
Fuel pressure	=	3 bars under zero vacuum 2.5 bars under vacuum of 500 mbars
Value for : CO	=	0.3 % maximum
HC	=	100 ppm maximum
CO2	=	14.5 % minimum
Oxygen	=	0.97 < λ < 1.03

Temperature in $^{\circ}\text{C}$	0	20	40	80	90
Air temperature sensor Resistance in ohms	5000 to 7000	2000 to 3000	1000 to 1500	-	-
Coolant temperature sensor Resistance in ohms	-	2000 to 3000	1000 to 1500	250 to 350	200 to 240

COOLING Specifications

19

COOLANT QUANTITY AND GRADE

Engine	Quantity (In litres)	Grade	Special notes
L7X	7	GLACEOL RX (type D) only add coolant	Protection down to $-20\pm 2^{\circ}\text{C}$ for hot, temperate and cold countries Protection down to $-37\pm 2^{\circ}\text{C}$ for extreme cold countries

THERMOSTAT

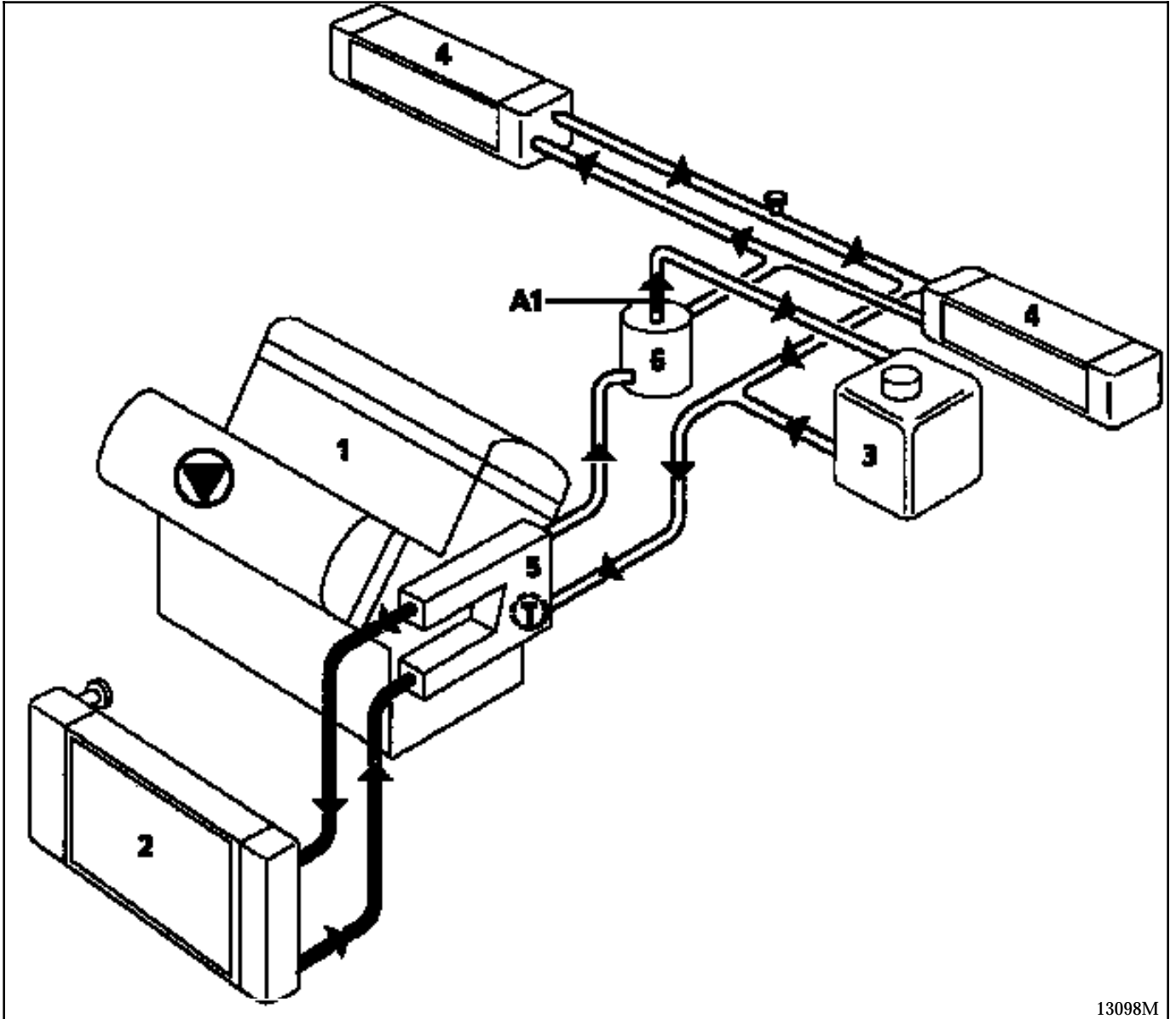

Engine type	Beginning of opening (in °C)	End of opening (in °C)	Travel (in mm)
L7X	83	95	7.5



13098M

- 1 Engine
- 2 Radiator
- 3 "Hot" bottle with permanent degassing
- 4 Heater matrix
- 5 Coolant outlet housing
- 6 Degasser housing

— Restriction: A1 3 mm diameter

-  Water pump
-  Dual effect thermostat
-  Bleed valves

The expansion bottle cap is rated at **1.2 bar**
(brown)

Circulation occurs continuously in the heater matrix, contributing to the cooling of the engine.

FILLING

The bleed valves on the heater hose and the engine outlet hose **MUST** be opened.

Fill the circuit via the expansion bottle opening.

Tighten the bleed screws as soon as the liquid starts running out in a continuous jet.

Start the engine (**2 500 rpm**).

Adjust the level by overflow for approximately **4 minutes**.

Close the reservoir.

BLEEDING

Allow the engine to run for **20 minutes** at **2500 rpm**, until the fan assembly begins to operate (time required for automatic degassing).

Check that the level of the liquid is close to the "**Maximum**" mark.

DO NOT OPEN THE BLEED SCREWS WHILE THE ENGINE IS RUNNING.

TIGHTEN THE EXPANSION BOTTLE CAP WHILE THE ENGINE IS WARM.

REMOVAL

Place the vehicle on a two post lift.

Disconnect the battery.

Drain the cooling circuit via the lower radiator hose.

Remove:

- the air filter assembly and its mounting,
- the support (1),
- the hoses (2),
- tubes (3) and (4),

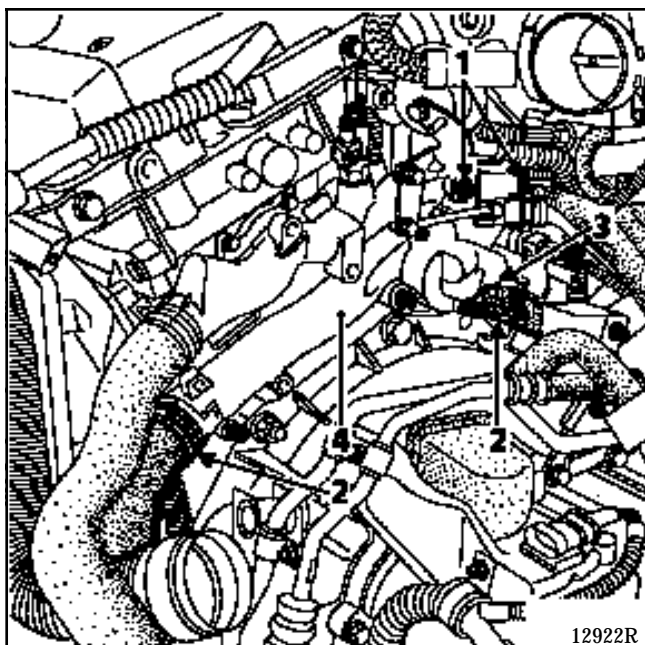

- the thermostat.

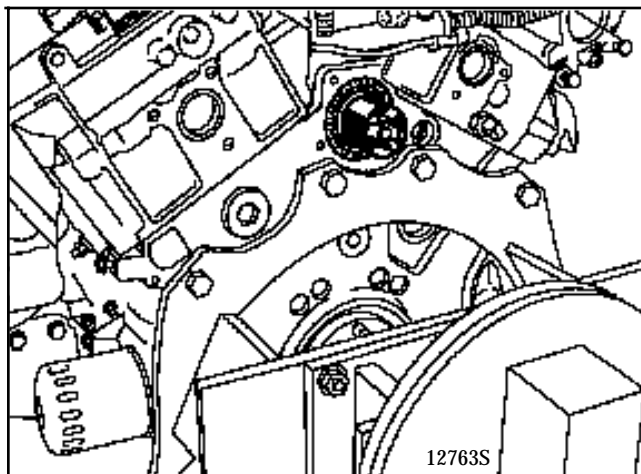

REFITTING

Refitting is the reverse of removal.

SPECIAL TOOLING REQUIRED		
Mot.	1273	Tool for checking belt tension
Mot.	1282 -01	Spanner for removing HP steering rack union
Mot.	1289 -02	Fork for centring the suspended engine mounting movement limiter
Mot.	1390	Engine support tool
Mot	1410	Tool for removal/refitting of refrigerant fluid unions
Mot.	1428	Tool for immobilising the camshaft hub
Mot	1429	Dynamic tensioner regulator
Mot.	1430	Camshaft and crankshaft sprocket timing pin
Mot.	1430 -01	Camshaft and crankshaft sprocket timing testing pin
Mot.	1436	Timing belt retaining pin
Tav.	476	Ball joint extractor
EQUIPMENT REQUIRED		
Ball joint separator		

TIGHTENING TORQUES (in daN.m)	
Dynamic tensioner bolt for the timing	2.5
Suspended engine mounting cover bolt	6.2
Timing pulley bolt	8
Wheel bolt	10

REMOVAL

The engine and transmission assembly have to be removed for the removal and refitting of the water pump.

See **Section 10 "Removal - refitting of the engine and transmission assembly"**.

Remove:

- the timing belt (see method described in **Section 11 - Timing belt**),
- the dynamic tensioner for the timing (1),
- the pulleys (2),
- the support (3) and remove it from above (if necessary, lift the engine using the engine support tool).

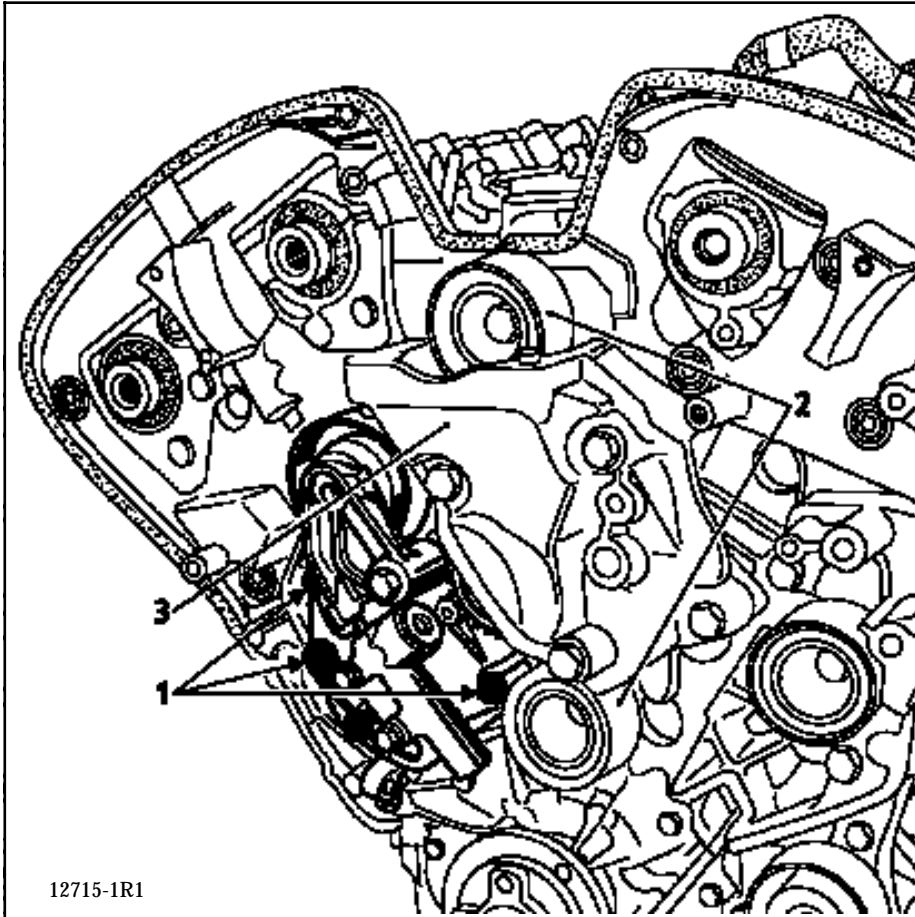

12715-1R1

Remove the water pump in the following order: bolts (4) and (5) then bolt (6).

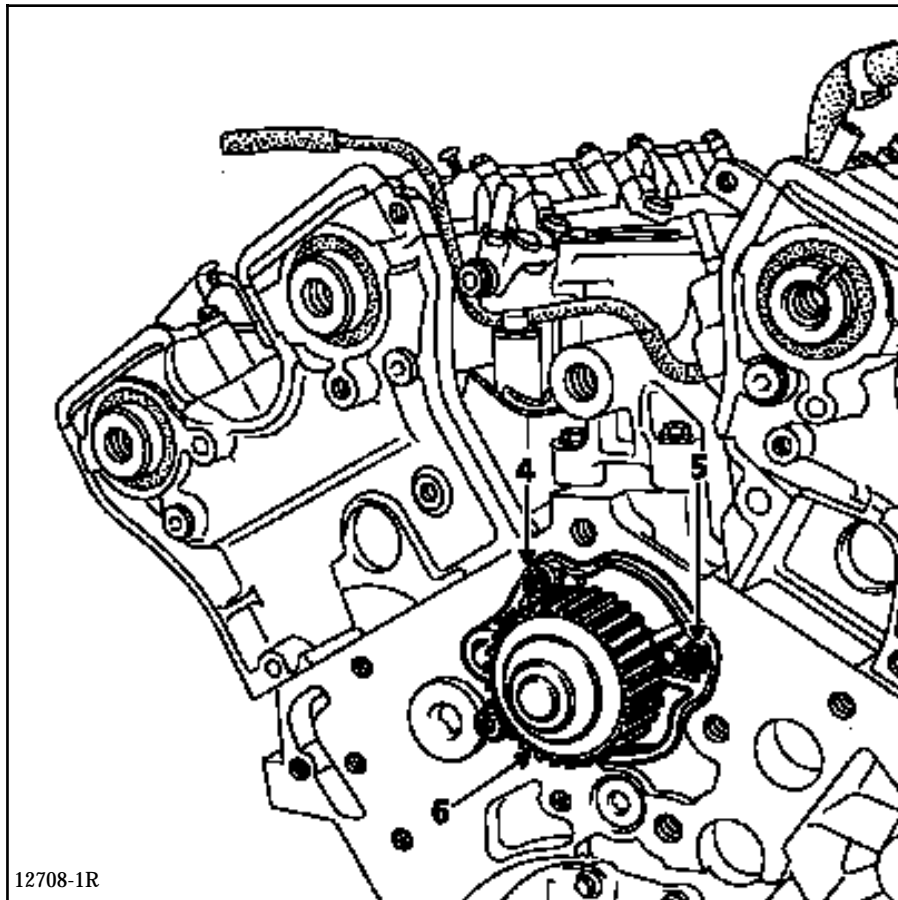

REFITTING

Refit the water pump fitted with a new gasket.

Observe the order of tightening (4), (5), (6) and tighten to a torque of **0.8 daN.m**.

Refit the timing belt (see method described in **Section 11 - Timing belt**).

Fill and bleed the cooling circuit (see **Section 19 - Filling and bleeding**).

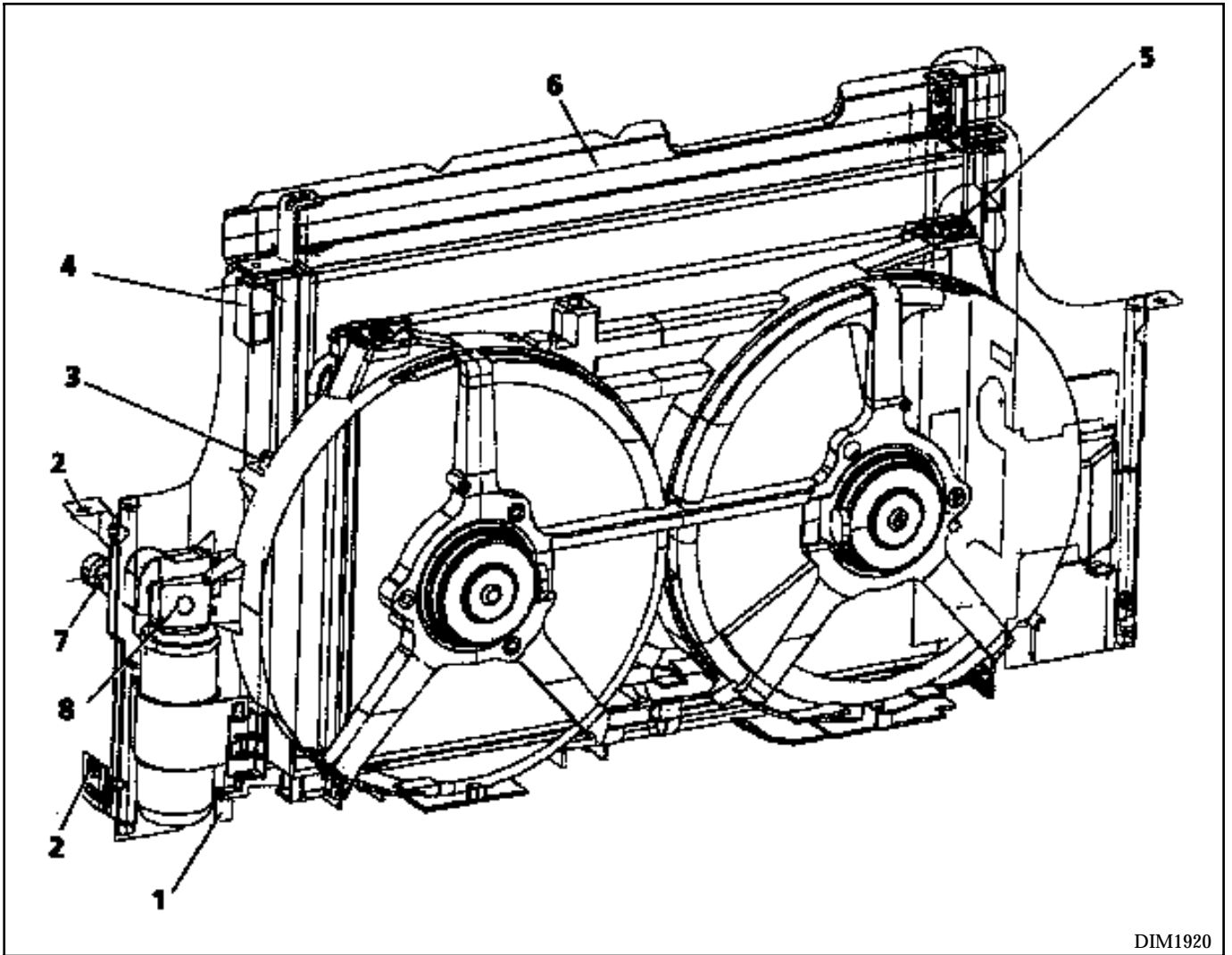

DIM1920

- 1 Engine cooling radiator centring pins in the front cross member
- 2 Side member fixing positions
- 3 Vent mountings on the radiator; the lower section fits against the radiator
- 4 Sliding radiator mountings on the headlight carrier cross member
- 5 Upper condenser mountings on the vents
- 6 Upper radiator sealing panel
- 7 Air conditioning condenser trifunction pressostat
- 8 Dehydration canister mounting on the vents

Place the vehicle on a 2 post lift.

Disconnect and remove the battery.

Drain the refrigerant circuit (if equipped) using the filling station.

Remove the radiator grille, the radiator grille bar and the front bumper (move the left hand wheel arch to one side to gain access to the two bolts).

If the vehicle is fitted with front fog lights, disconnect them.

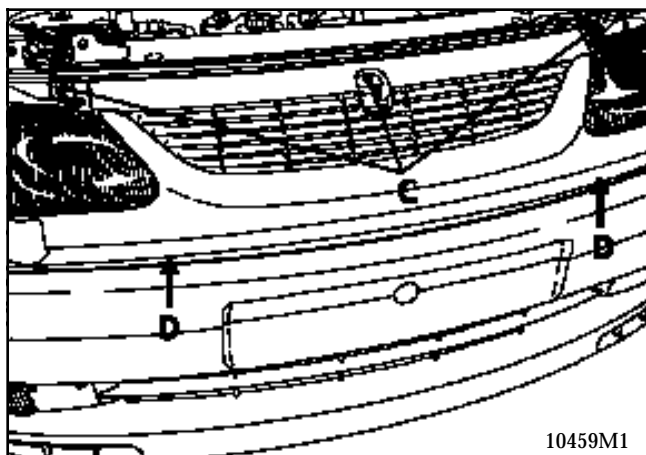

10459M1

Drain the engine cooling circuit by disconnecting the lower radiator hose.

Unclip the PAS oil pipe and attach it to the engine if necessary.

Remove the deflector mounting bolts on the side members.

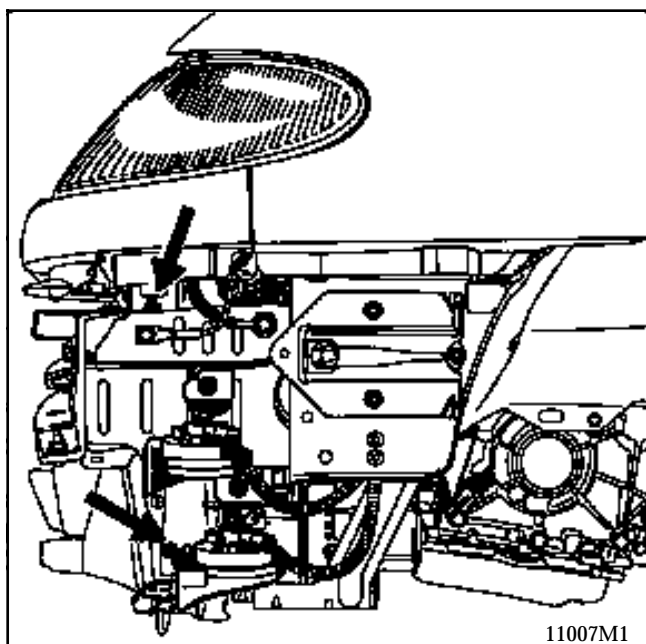

11007M1

Fold the deflectors towards the cooling assembly.

Remove the flange mounting bolt from the air conditioning circuit pipes on the dehydration canister.

Disconnect the trifunction pressostat.

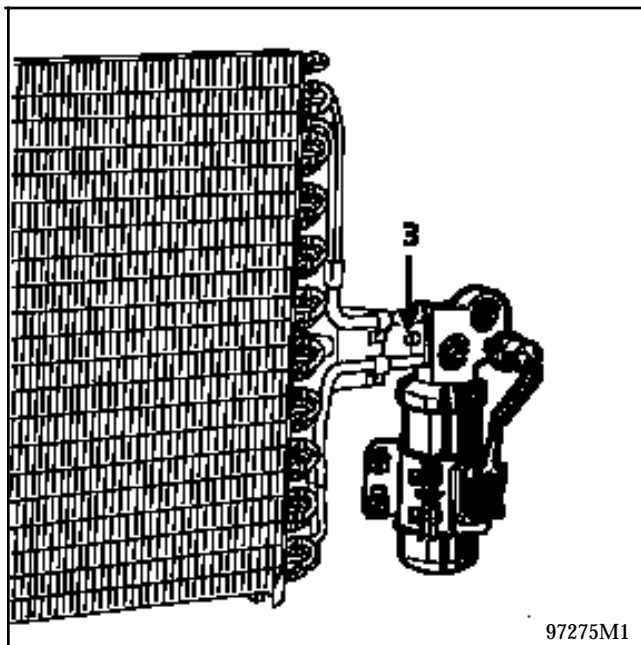

97275M1

Disconnect:

- the upper radiator hose,
- the radiator temperature switch.

Detach the cooling assembly wiring.

Set the lower radiator cross member on one or two shims to support it and access the mounting bolts on the ends of the side members.

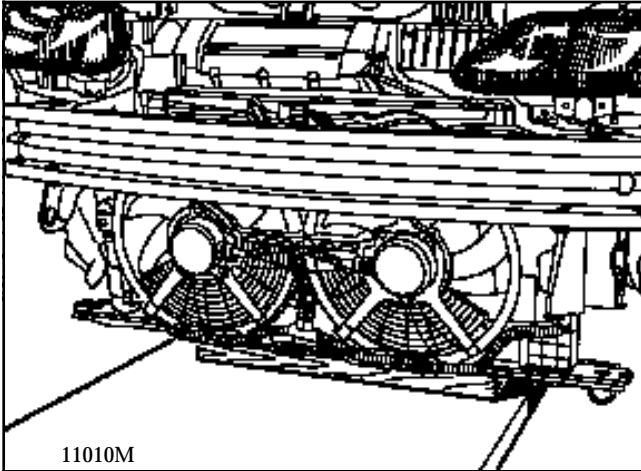

Remove the two cross member mounting bolts on the side members and raise the vehicle to remove the cooling assembly.

REFITTING

Use two people to refit the cooling assembly; if necessary, lubricate the upper rubber mounting pads on the headlight carrier panel cross member.

Refitting is the reverse of removal.

Fill the refrigerant circuit (if equipped) and the cooling circuit.

Bleed the engine and check the sealing of the cooling and air conditioning circuits.

ENGINE MOUNTING

Suspended engine mounting

TIGHTENING TORQUES (daN.m)

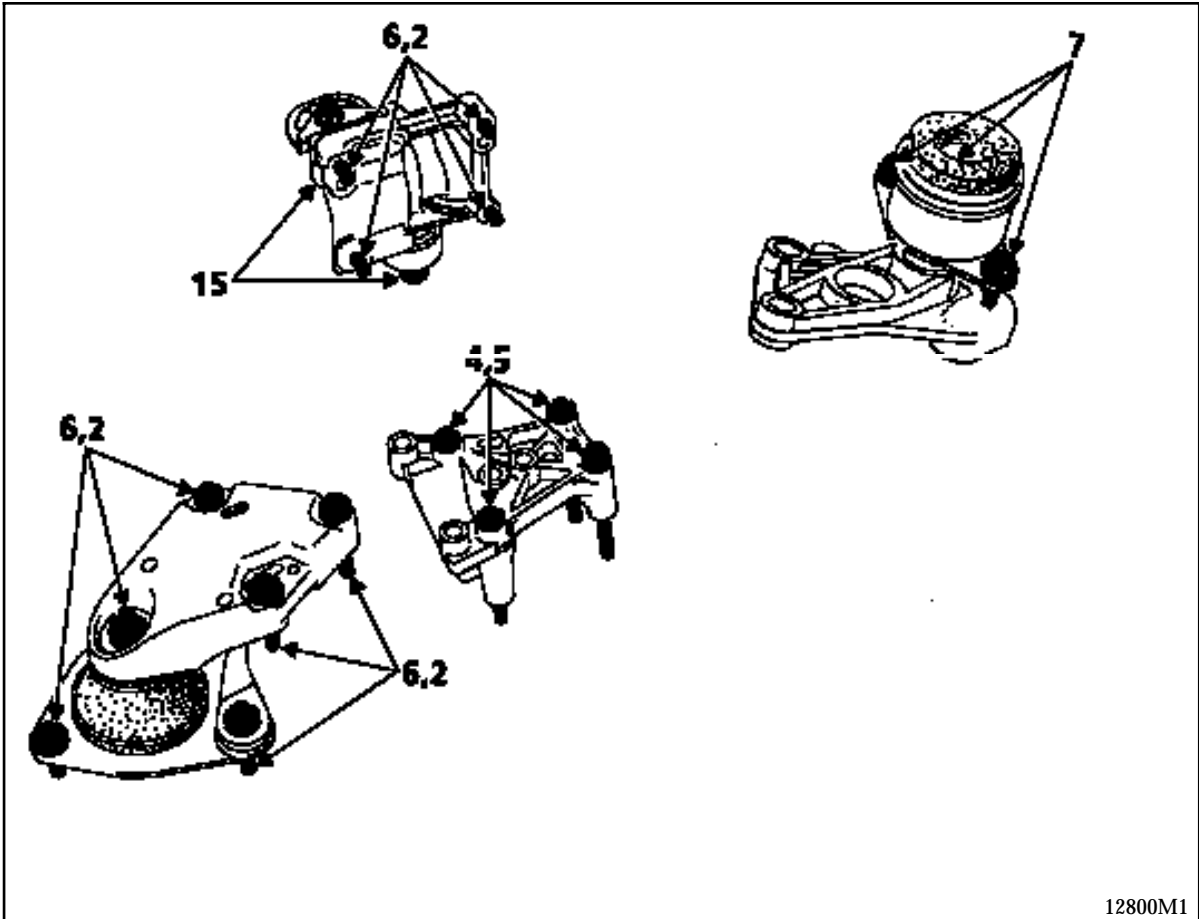

12800M1

AUTOMATIC TRANSMISSION

General

23

VEHICLE	AT TYPE	ENGINE	STEPDOWN	FINAL DRIVE RATIO	COMPUTER
JE0 G02/GL2	LM0 001	L7X 727	58/71	20/69	77 00 105 003

Automatic transmission identification plate.

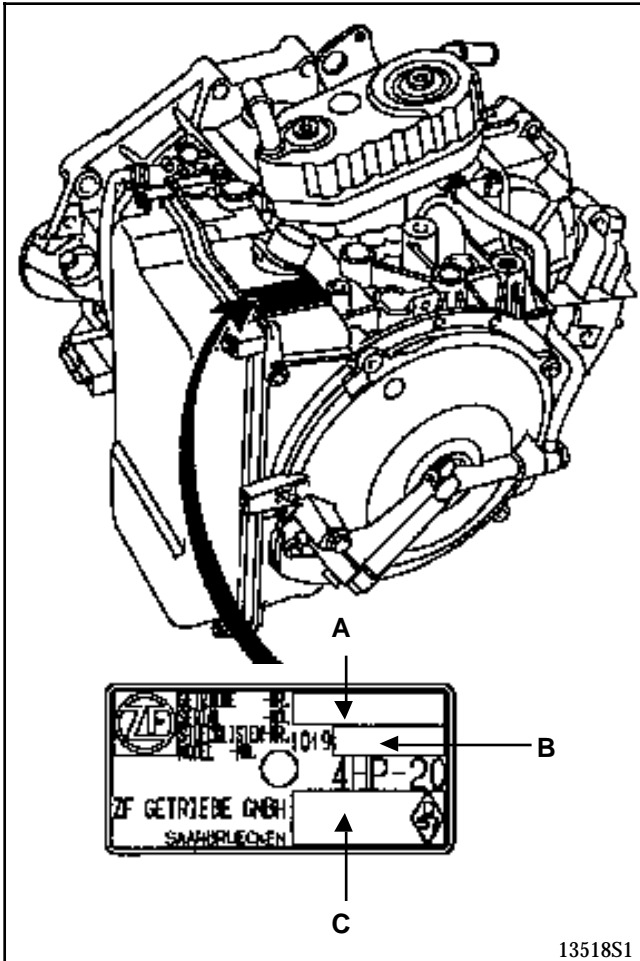

- A Serial number.
- B ZF part number.
- C Automatic transmission type and suffix.

SPECIFICATIONS

Weight: 88 kg filled

Gear ratios (output from epicycloidal axles):

1st	2nd	3rd	4th	Reverse
2.72	1.48	1	0.72	- 2.57

DESCRIPTION	COMPONENT CONCERNED
MOLYKOTE BR2 lubricant	- Driveshaft relay shaft splines - Converter centring device
Loctite FRENBLOC	Brake caliper mounting bolts
Loctite FRENETANCH	Distributor bolts
Loctite 518	Distributor housing

Components to be systematically replaced

Components to be replaced once they have been removed:

- self-locking nuts,
- seals,
- rubber seals.

Oil

Automatic transmission LM0 **is lubricated for life.**

Specified oil:

Oil with reference **SODICAM 77 11 172 226** or **ESSO LT71141** .

See **Section 5** for oil change intervals, oil draining intervals and checking the oil level.

TIGHTENING TORQUES (in daN.m)	
Cover mounting bolts	0.6
Distributor mounting bolts	0.8

REMOVAL

Place the vehicle on a two post lift.

Disconnect the battery.

Drain the automatic transmission (see **Section 05**).

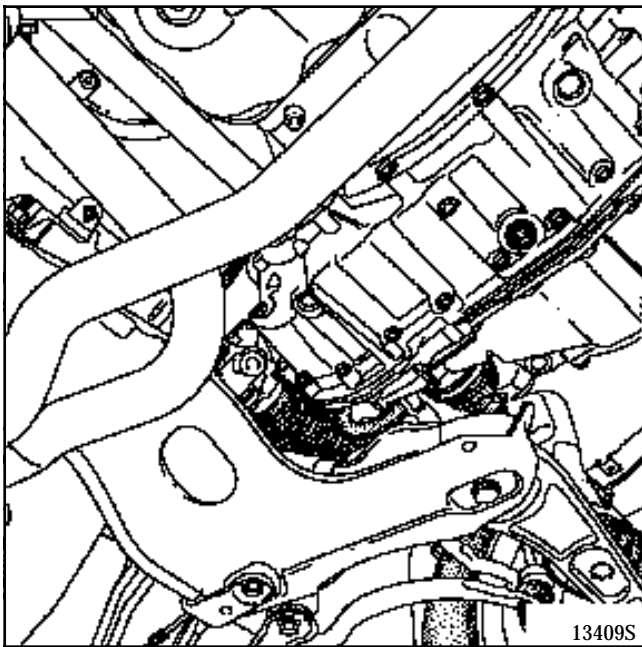

Remove:

- the battery,
- the automatic transmission computer,
- the battery tray,
- the air filter unit,
- the air filter mounting,

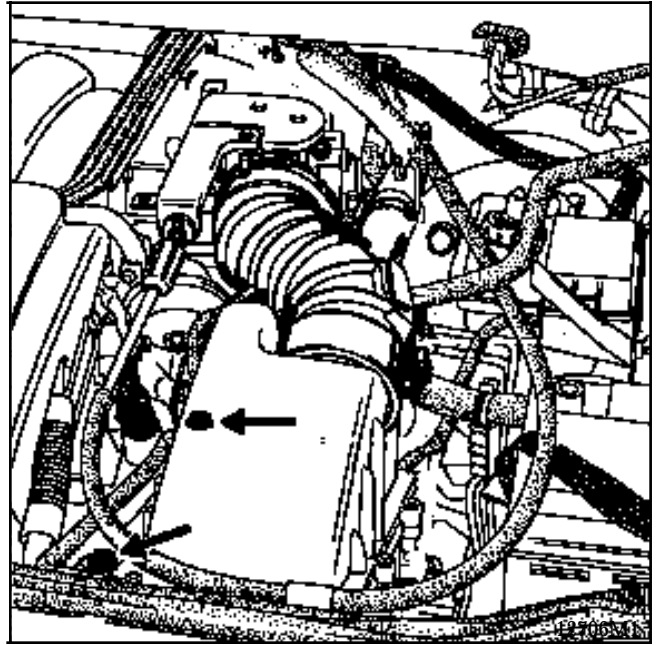

- the wiring carrier plate mounting bolts (A).

Disconnect connector (B) and remove the retaining clip.

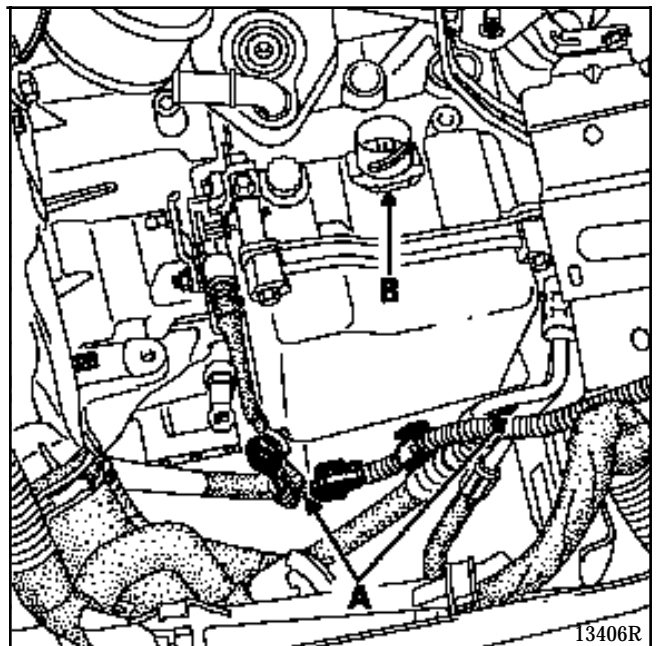

Remove:

- the four hydraulic distributor cover retaining bolts (be careful, oil may run out),
- the input speed sensor mounting bolt,
- the seven hydraulic distributor mounting bolts.

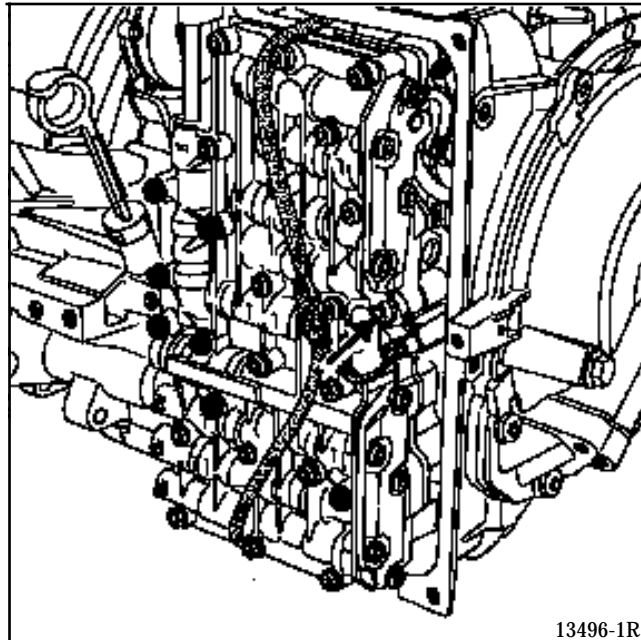

Move the distributor to one side and remove the output speed sensor mounting bolt.

Keep the sensor adjusting washer (if there is one).

REFITTING

Offer up the hydraulic distributor and refit the output speed sensor. **Do not forget the adjusting washer if there is one.**

Refit:

- the wiring and the clip,
- the hydraulic distributor mounting bolts, tightened to the correct torque,
- the cover (clean the magnets).

Check that the manual valve control operates correctly.

Refitting is the opposite of removal.

Carry out function G80** using the XR25.

AUTOMATIC TRANSMISSION

Automatic transmission (Removal - Refitting)

SPECIAL TOOLING REQUIRED	
T. Av. 476	Ball joint extractor
Mot. 1282-01	Tool for removing the PAS HP union on the steering rack
Mot. 1289-02	Fork for centring the suspended engine mounting limiter
Mot. 1390	Engine and transmission assembly mounting tool
Mot. 1410	Tool for removing refrigerant fluid unions
EQUIPMENT REQUIRED	
Ball joint separator	

TIGHTENING TORQUES (in daN.m)	
Brake caliper bolts	3.5
Lower ball joint nut	6.5
Shock absorber base bolt	20
Engine tie bar bolt	15
Bolts at edge of gearbox and starter motor	6
Front left hand suspended engine mounting nut on side member	8
Tapered suspended engine mounting bolt on the gearbox bolt	7
Suspended engine mounting bolt on gearbox	4
Wheel bolts	10
Track rod end nut	4
Starter plate mounting bolt on converter	6
Exchanger mounting bolt	3.5
Casing connection bolt	2.5

REMOVAL

The engine and transmission assembly has to be removed for removal and refitting of the automatic transmission.

See **Section 10 "Removal - Refitting of the engine and transmission assembly"**.

Remove the wiring carrier plate mounting bolts (A).

Disconnect connector (C).

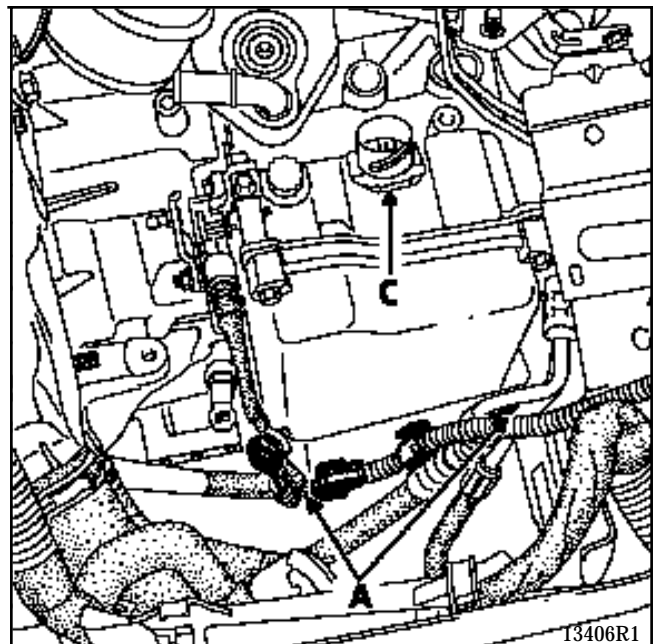

Remove:

- the hoses,
- the coolant/oil exchanger (fragile component),

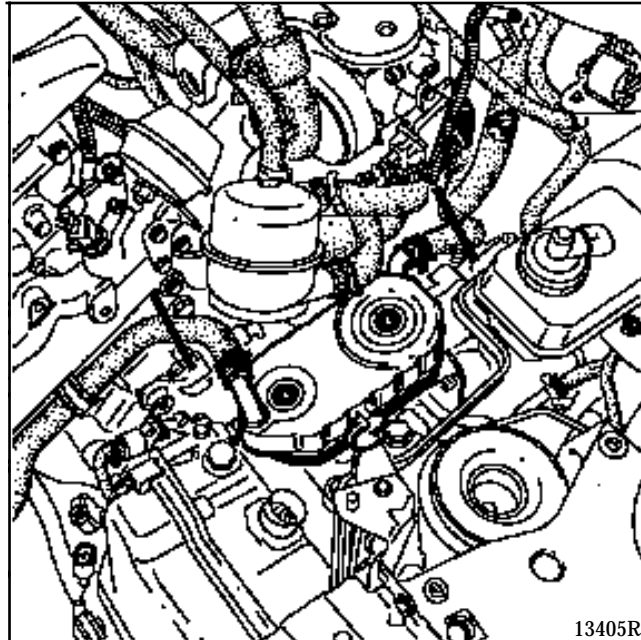

- the upper gearbox surround bolts,
- the automatic transmission lifting bracket (casing connection bolt),
- the TDC sensor (**using a ratchet (6.35 mm square) and a small extender**),
- the converter lower protective panel.

Turn the crankshaft clockwise to gain access to the three bolts which connect the starter plate to the converter and remove them.

Remove the last gearbox bolts and uncouple the automatic transmission from the engine, taking care not to unseat the converter.

Keep the plastic converter centring ring.

REFITTING

Refit the plastic centring ring.

Check that the converter is correctly positioned using a surface size scale and a ruler. Distance X should be approximately 11 mm.

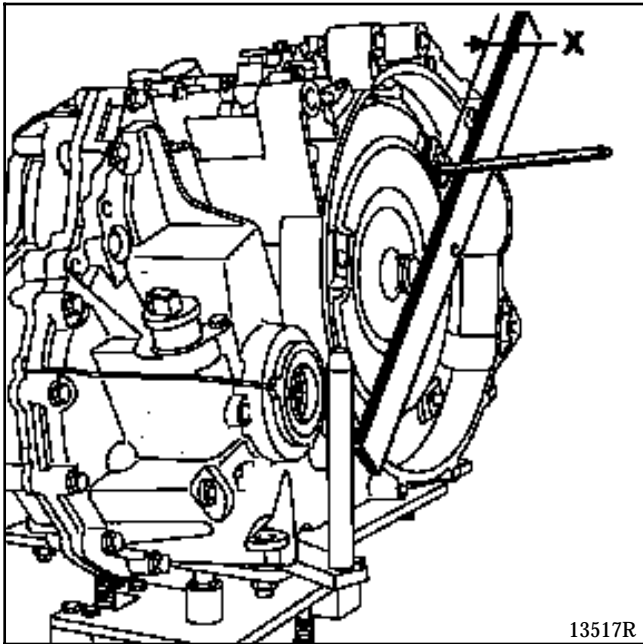

Use a trammel (P) to make it easier to position the converter.

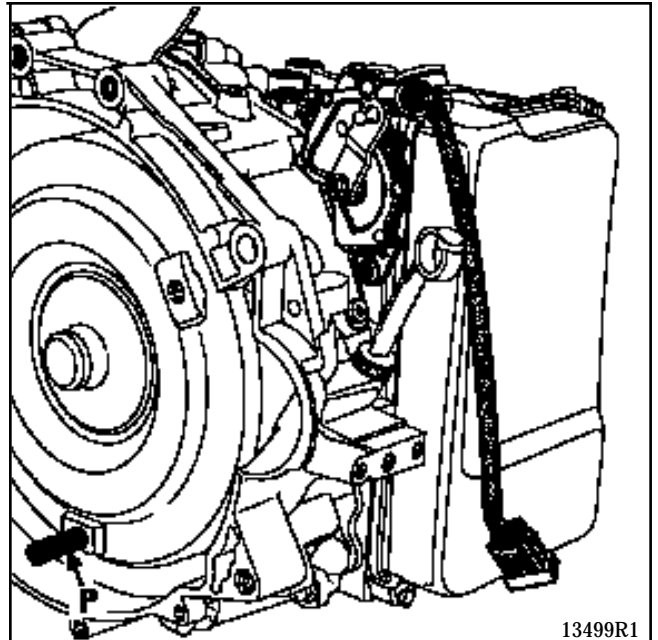

DO NOT USE ANY BOLTS OTHER THAN THE ORIGINAL BOLTS PROVIDED FOR FITTING THE CONVERTER TO THE STARTER PLATE

Refit the gear selector cable in position **D** at the gearbox and at the selector (see section "Multifunction switch").

Replace the exchanger seals.

Refitting is the reverse of removal.

Torque tighten the nuts and bolts.

Carry out function G80** using the XR25.

AUTOMATIC TRANSMISSION

Differential output seal

23

SPECIAL TOOLING REQUIRED

B. Vi. 1078 Seal refitting tool

TIGHTENING TORQUES (in daN.m)	
Brake caliper bolt	3.5
Lower ball joint nut	6.5
Shock absorber base bolt	20
Wheel bolts	10
Track rod end nut	4
Drain plug	3.5

To replace a differential output seal, the corresponding driveshaft must be removed.

REMOVAL

Place the vehicle on a two post lift.

Disconnect the battery.

Drain the automatic transmission via plug (A).

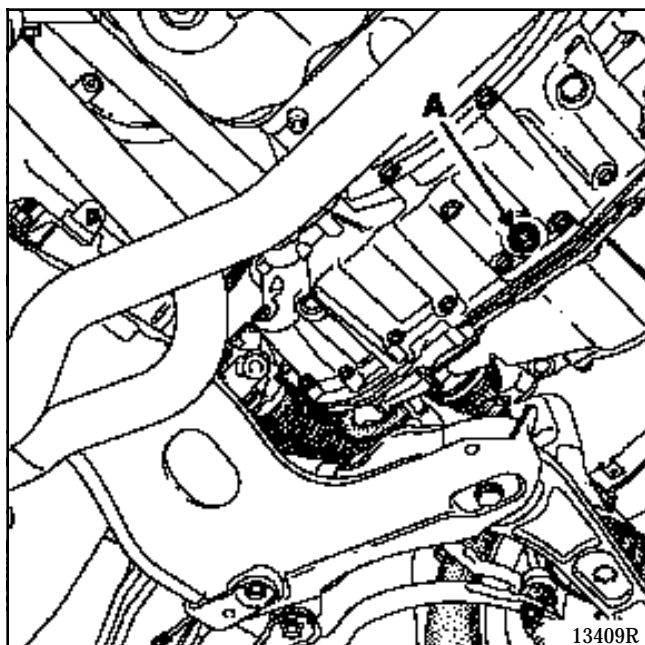

Remove the faulty differential output seal using a screwdriver or a hook, taking care not to scratch the contact surfaces.

Take care not to let the seal spring fall into the automatic transmission.

REFITTING

The seal is fitted using tool **B. Vi. 1078** or using a deburred tube with a minimum internal diameter of **45 mm**.

Guide the assembly until the tool is in contact with the automatic transmission casing.

Refitting is the reverse of removal.

TIGHTEN THE NUTS AND BOLTS TO THE RECOMMENDED TORQUE.

Fill the automatic transmission and check the level (refer to the relevant section).

SPECIAL TOOLING REQUIRED	
B. Vi. 1078	Seal refitting tool

The converter seal can only be removed after removal of the automatic transmission and the converter (refer to the relevant section).

REMOVAL

Remove the converter, taking it out as close as possible to the centreline.

Take care, the converter contains a significant quantity of oil which may run out during removal.

Using a screwdriver or a hook, remove the seal taking care not to scratch the contact surfaces.

REFITTING

The operation must be carried out with the utmost care. Lubricate all the contact surfaces.

Refit the new seal (lubricated) fully back in place using tool **B. Vi. 1078**.

Check that the converter is correctly positioned using a scale and a ruler. Distance X should be approximately **11 mm**.

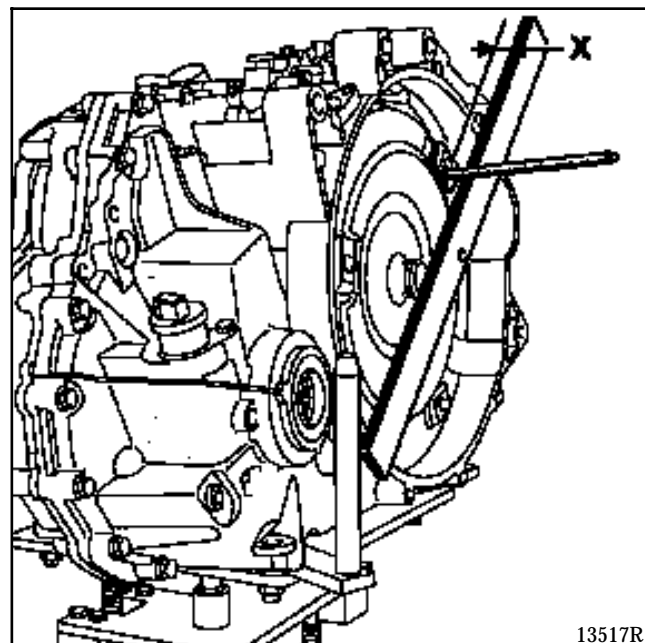

13517R

TIGHTENING TORQUES (in daN.m)	
Multifunction switch mounting bolt	1
Lever mounting nut	2

REMOVAL

Set the selector on position **D**.

Disconnect:

- the battery,
- the accelerator cable.

Remove:

- the air filter unit,
- the air filter mounting,

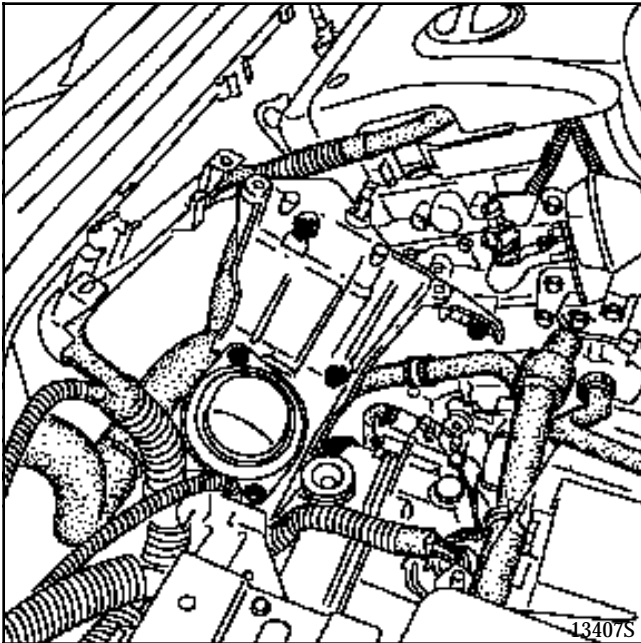

- the air intake pipe,
- the lever and the two multifunction switch mounting bolts.

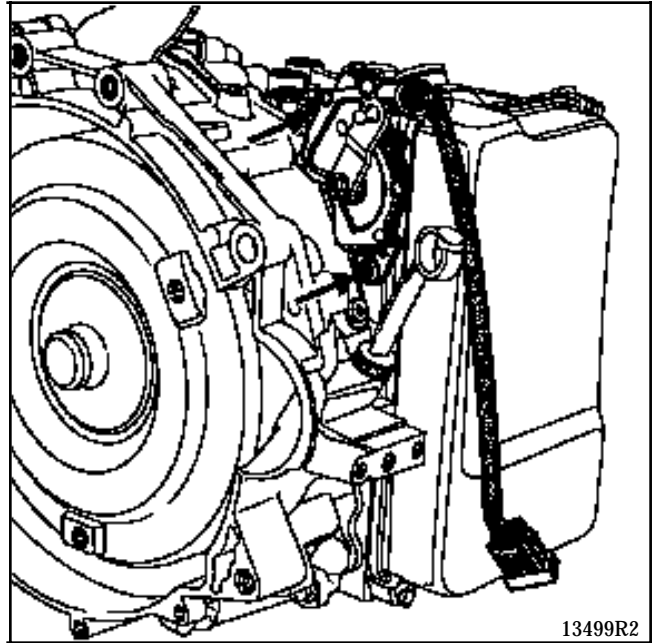

IMPORTANT: Never remove the multifunction switch lever without immobilising it.

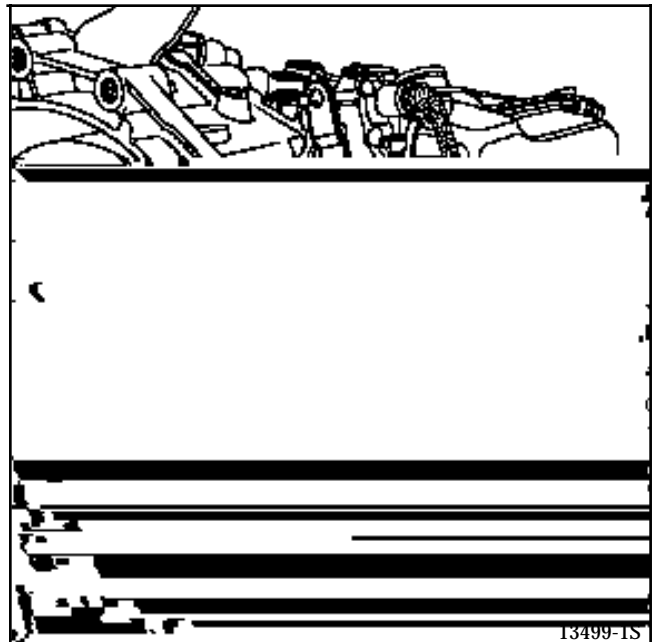

IMPORTANT: NEVER REMOVE THE POSITIONING PLATE LOCATED BEHIND THE MULTIFUNCTION SWITCH.

REFITTING

Set the multifunction switch to position **D** (the lever notch is then opposite the highest rivet).

Refit:

- the new multifunction switch,
- the lever as indicated above.

Reconnect:

- the multifunction switch connector,
- the control cable.

Refitting is the reverse of removal.

**TIGHTEN THE BOLTS AND NUTS TO THE
RECOMMENDED TORQUES.**

Check that "**D**" on the vehicle corresponds to "**D**" on the automatic transmission.

The automatic transmission speed sensors can only be removed after removal of the hydraulic distributor cover (refer to the "**Hydraulic distributor**" section).

TIGHTENING TORQUES (in daN.m)	
Cover mounting bolt	0.6
Distributor mounting bolt	0.8
Input speed sensor mounting bolt	0.8
Output speed sensor mounting bolt	1

INPUT SPEED SENSOR

REMOVAL

Remove speed sensor mounting bolt (V).

Disconnect the sensor connector.

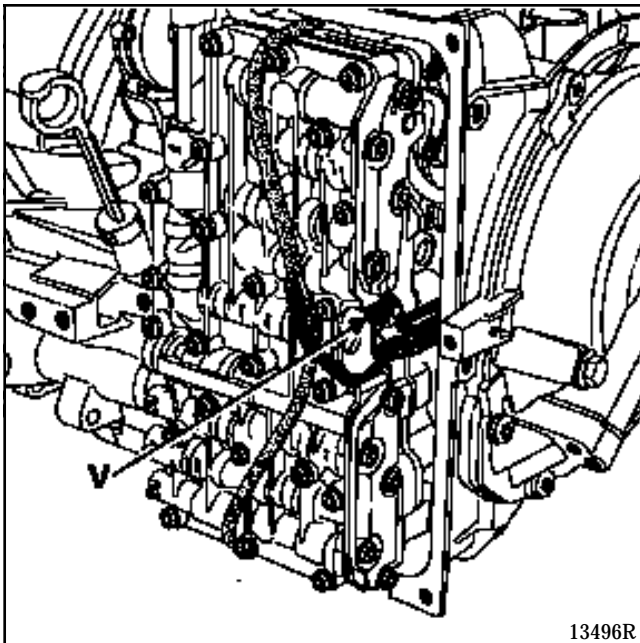

REFITTING

Refitting is the reverse of removal.

OUTPUT SPEED SENSOR

REMOVAL

Remove:

- the automatic transmission input speed sensor,
- the hydraulic distributor mounting bolts.

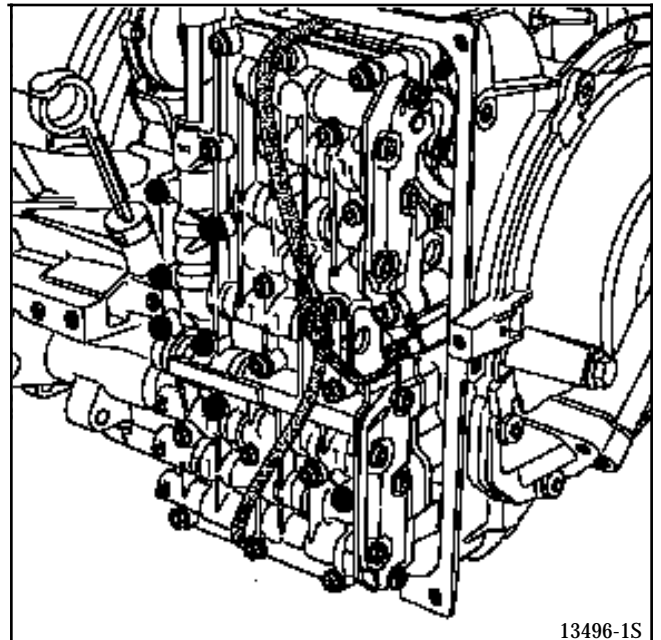

Place the distributor on, for example, a component jack.

Remove the output speed sensor mounting bolt. **Keep the sensor adjusting washer (if there is one).**

Disconnect the sensor connector.

REFITTING

Refitting is the reverse of removal.

Do not forget the adjusting washer if there is one.

REMOVAL

The oil temperature sensor is integrated in the hydraulic distributor wiring harness.

The entire electrical wiring harness must be replaced in order to replace the oil temperature sensor.

The hydraulic distributor must be removed (refer to the relevant section).

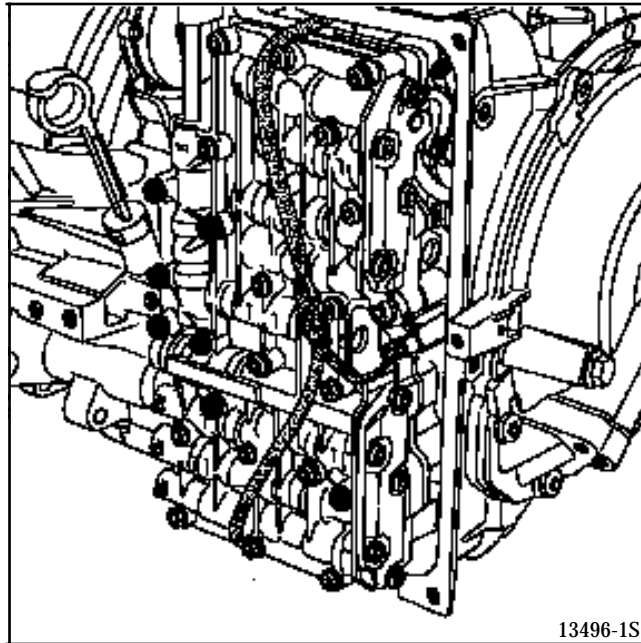

REFITTING

Position the wiring harness, retaining it using the hydraulic distributor clips.

Take care not to pinch the wiring harness when refitting the hydraulic distributor.

The hydraulic distributor must be removed in order to remove the solenoid valves (refer to the relevant section).

IDENTIFICATION

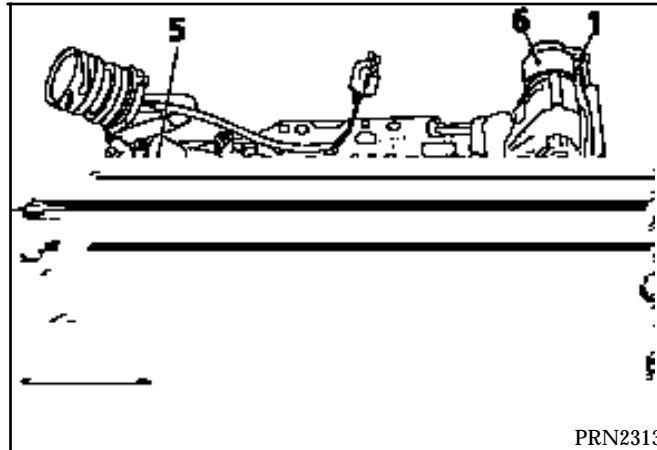

- 1 Solenoid valve **EVS1**
- 2 Solenoid valve **EVS2**
- 3 Pressure modulating solenoid valve **EVM3**
- 4 Pressure modulating solenoid valve **EVM4**
- 5 Pressure modulating solenoid valve **EVM5**
- 6 Pressure modulating solenoid valve **EVM6**
- 7 Temperature sensor

REMOVAL

Place the vehicle on a two post lift.

Disconnect the battery.

From underneath, remove the vehicle speed sensor mounting bolt.

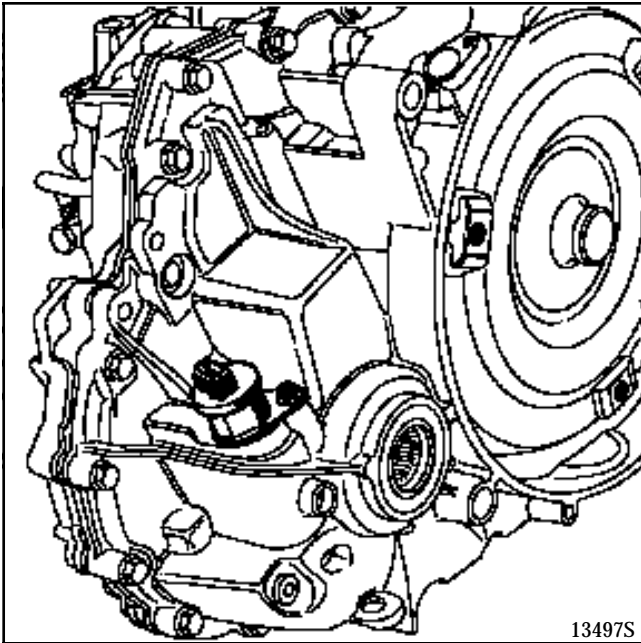

Replace the speed sensor pin if necessary.

REFITTING

Place the speed sensor pin in its housing and check that it is correctly positioned.

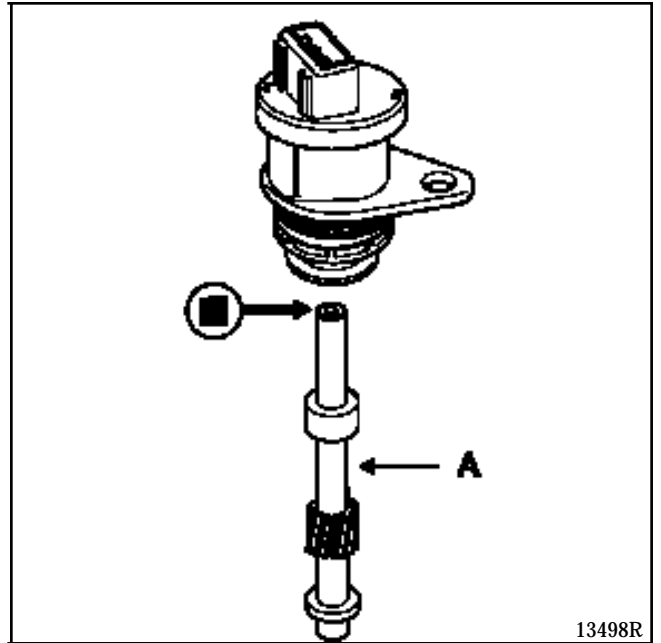

Refitting is the reverse of removal.



Important: the speedometer drive pin is not captive. Pull the sensor gently and catch pin (A) to prevent it from falling into the gearbox.

CONDITIONS FOR APPLYING THE CHECKS IN THIS FAULT FINDING

The checks defined in this fault finding are only to be applied to vehicles if the description of the fault being dealt with corresponds exactly to the display on the XR25.

If a fault is dealt with following flashing of a bargraph, the conditions for confirming the actual presence of the fault (and the need to apply fault finding) are given in the "Notes" or at the beginning of the bargraph interpretation.

If a bargraph is only interpreted if it is permanently illuminated, carrying out the checks recommended in the fault finding information when the bargraph is flashing will not enable the origin of the storing of the fault to be located. In this case, only a check of the wiring and the connectors of the faulty component must be carried out.

Note: - The ignition must have been switched off before the XR25 is operated.
- The lever must be in position P.

TOOLING REQUIRED FOR FAULT FINDING OPERATIONS ON LM0 AUTOMATIC TRANSMISSION

- XR25.
- XR25 cassette N° 17 minimum.
- Multimeter.
- 88 track testing bornier, ELE. 1422.

Important: The AT LM0 computer uses auto-adaptive parameters to manage gear changes and the "Lock-up" function. These auto-adaptive values optimise the pressure and the time taken to fill the brakes and clutches depending on the mechanical/hydraulic specifications specific to each automatic transmission. Therefore, if any component which has an effect on these parameters is replaced, the stored values must be updated. The auto-adaptive values are reset to zero using XR25 command G80**. When command G80** has been used, it is important to carry out a road test enabling all gear changes, up and down, to be made several times to store the new values.

The auto-adaptive values must be reset to zero when the following components are replaced:

- Hydraulic distributor.
- Torque converter.
- Solenoid valve.
- Complete automatic transmission.

AUTOMATIC TRANSMISSION

Fault finding - XR25 fiche

23

XR25 FICHE N° 62

N°62	S8	code : D 1 4	read : n62
-------------	-----------	---------------------	-------------------

1	<input type="checkbox"/> COMPUTER	CODE PRESENT <input type="checkbox"/>
2	<input type="checkbox"/> + BEFORE IGNITION	ACTIVATOR SUPPLY *22 <input type="checkbox"/>
3	<input type="checkbox"/> LOAD INFORMATION	GEARBOX OIL TEMP <input type="checkbox"/>
4	<input type="checkbox"/> LEVER POSITION INFO	KICKDOWN <input type="checkbox"/>
5	<input type="checkbox"/> *05 SELECTOR LEVER LOCK	
6	<input type="checkbox"/> *06 TORQUE REDUCTION	ENGINE TORQUE <input type="checkbox"/>
7	<input type="checkbox"/> G. BOX OUTPUT SPEED	
8	<input type="checkbox"/> TURBINE SPEED	ENGINE SPEED <input type="checkbox"/>
9	<input type="checkbox"/> CLUTCH OVERLAP (gear changes)	
10	<input type="checkbox"/> OVER-REVVING	CONSISTENT WITH GEAR CHANGE <input type="checkbox"/>

LM O

Erase fault memory : G 0 **
End of test : G13 *

<input type="checkbox"/> *11 EVS1	<input type="checkbox"/> EVS2 *31
<input type="checkbox"/> *12 EVM3	<input type="checkbox"/> EVM5 *32
<input type="checkbox"/> *13 EVM4	<input type="checkbox"/> EVM6 *33

LOW ADHERENCE SELECTION

KICKDOWN

BRAKE PRESSED → correct if brake pressed (remains exting.)

FAULT TELL-TALE

SOLS1 **SOL CONTROLS** SOLS2

SPORT with lever lock

without kickdown switch

ADDITIONAL CHECKS : #...

01 Gear engaged and lever position

04 Oil temperature °C

05 G. box output speed /rpm

06 Engine speed /rpm

07 Turbine speed /rpm

08 Computer feed V

12 Load pot. (converted load) %

COMMAND MODES : #...

23 Selector lever lock (Phase 2)

27 Output tests

Help : V9

Return to diag.mode : D

Part No : G70 *

18 ANG

FI21862

BARGRAPH SYMBOLS

FAULTS (always on a coloured background)



If illuminated, indicates a fault on the product tested. The associated text defines the fault.

This bargraph may be:

- Illuminated : fault present.
- Flashing : fault memorised.
- Extinguished : fault absent or not detected.

STATUS (always on white background)



Bargraph always located on the top right hand side.

If illuminated, indicates that dialogue has been established with the product computer.

If it remains extinguished:

- The code does not exist.
- There is a tool, computer or XR25/computer connection fault.

The representation of the following bargraphs indicates their initial status:

Initial status: (ignition on, engine stopped, no operator action).



or



Undefined

illuminated when the function or condition specified on the fiche is being met.

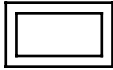

Extinguished



Illuminated

extinguished when the function or condition specified on the fiche is no longer being met.

ADDITIONAL INFORMATION

Some bargraphs have a *. The command *.., when the bargraph is illuminated, enables additional information regarding the type of fault or the status to be displayed.

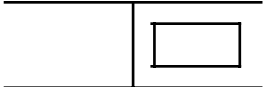
<p style="margin: 0;">1</p> 	<p>Bargraph 1 RH side extinguished</p> <p><u>Code present</u></p>	<p>Fiche n° 62</p>
---	--	--------------------

NOTES	None
--------------	------

Ensure that the XR25 is not the cause of the fault by trying to communicate with a computer on another vehicle. If the XR25 is not faulty and dialogue is not established with any other computer on the same vehicle, a faulty computer may be disrupting diagnostic lines **K** and **L**. Locate the faulty computer by disconnecting each computer in turn.

Check that the ISO selector is in position **S8**, that you are using XR25 cassette 18 and the correct access code.

Check the battery voltage and carry out the operations necessary to obtain a voltage which is correct to specification (**9 volts < U battery < 16 volts**).

Check whether the **5 A** AT fuse on the passenger compartment connection unit has blown (if a **5 A fuse** blows again after it has been replaced, first look for a short circuit to earth of one of the 4 multifunction switch lines or a short circuit to 12 volts of the P/N/E connection between the injection and AT computers). If the fuse blows when the kickdown switch, the "poor grip" or "3rd gear hold" selectors are operated, look for a short circuit to **12 volts** on the circuits concerned.

Check the connection and condition of the computer connector connections and the engine/dashboard connection (in the passenger compartment connection unit **R262 clear connector clear track A8**).

Check that the computer is correctly fed:

- **Earth** on tracks **28 and 34**.
- **+after ignition feed** on tracks **31 and 54**.

Check that the diagnostic socket is correctly fed:

- **Earth** on track **5** of the 16 track diagnostic socket.
- **+before ignition feed** on track **16** of the 16 track diagnostic socket.

Check and ensure the continuity and insulation of the diagnostic socket / computer connection lines:

- Between **track 47** of the computer connection and **track 15** of the 16 track diagnostic socket.
- Between **track 50** of the computer connection and **track 7** of the 16 track diagnostic socket.

If dialogue is still not established after these various checks, replace the computer and erase the fault memory at the end of the operation.

AFTER REPAIR	When communication has been established, deal with any illuminated fault bargraphs.
---------------------	---

<p>1</p> 	<p>Bargraph 1 LH side illuminated or flashing</p> <p><u>Computer</u></p>	<p>Fiche n° 62</p>
---	---	--------------------

NOTES	<p>None</p>
--------------	-------------

If the bargraph is flashing, erase the computer memory using command **G0****. Switch the ignition off then on again to reinitialise the computer. Replace the computer if the fault reappears.

If the bargraph is illuminated, replace the computer.

AFTER REPAIR	<p>Erase the computer memory (G0**).</p> <p>Switch off the ignition then carry out a road test.</p> <p>Complete the operation by carrying out a check using the XR25.</p>
---------------------	---

<p style="margin: 0;">2</p> 	<p>Bargraph 2 LH side illuminated <u>+ before ignition feed</u></p>	<p>Fiche n° 62</p>
--	---	--------------------

NOTES	None
--------------	------

Ensure the continuity of the connection between track **55** of the computer connection and the **3A injection fuse** on the passenger compartment connection unit. Intermediate engine / dashboard connection (in the passenger compartment connection unit **R262 white connector, clear track A2**).

Check the condition of all the connections.

AFTER REPAIR	<p>Erase the computer memory (G0**). Switch off the ignition then carry out a road test. Complete the operation by carrying out a check using the XR25.</p>
---------------------	---

<p style="margin: 0;">3</p> 	<p>Bargraph 3 RH side illuminated</p> <p><u>Oil temperature sensor circuit</u></p>	<p>Fiche n° 62</p>
---	---	--------------------

NOTES	None
--------------	------

Switch off the ignition, disconnect the 16 track connector on the automatic transmission and measure the resistance of the oil temperature sensor between **tracks 4 and 9** AT side.

If the resistance measured is not approximately **700 ohms < R < 1300 ohms at 20°C** (1400 to 1500 ohms at 80°C), replace the AT internal wiring (temperature sensor integrated in the wiring).

Check the computer and 16 track connector connections.

If the connections are correct, check and ensure the continuity and insulation of the connection between track **22** of the computer connection and **track 9** of the 16 track connector.

Check and ensure the continuity of the connection between track **21** of the computer connection and **track 4** of the 16 track connector.

Also ensure the insulation between these two connections.

If all the checks are correct, reconnect the computer connector and the 16 tracks on the AT, switch on the ignition then erase the computer fault memory.

Exit fault finding mode (**G13***) and switch off the ignition.

If the fault reappears when the ignition is switched on, replace the oil temperature sensor.

Erase the computer fault memory at the end of the operation.

AFTER REPAIR	<p>Erase the computer memory (G0**).</p> <p>Switch off the ignition then carry out a road test.</p> <p>Complete the operation by carrying out a check using the XR25.</p>
---------------------	--

<p style="margin: 0;">3</p> 	<p>Bargraph 3 LH side illuminated or flashing</p> <p><u>Throttle position information</u></p>	<p>Fiche n° 62</p>
---	--	--------------------

NOTES	<p>The throttle position information circuit fault is present if the bargraph is illuminated with the engine running at more than 2000 rpm.</p>
--------------	---

<p>Enter injection computer fault finding mode to see whether there is a load potentiometer fault. If there is a load potentiometer fault, follow the associated fault finding procedure in the relevant documentation.</p> <p>After the injection operation, return to automatic transmission fault finding mode to erase the computer fault memory.</p>
<p>If the load potentiometer is not faulty, check the connections at the injection computer and the automatic transmission computer.</p> <p>Ensure the continuity and insulation of the connection between track 38 of the automatic transmission computer connector and track 31 of the injection computer connector.</p> <p>Check that the engine compartment wiring routing is correct to specification (risk of interference of the connection).</p>

<p>Disconnect the AT computer, then remove the plastic closing cover from its connector to gain access to the rear of the connector clips.</p> <p>Reconnect the AT computer.</p> <p>Set the XR25 to pulse detection mode (function G, terminal Vin).</p> <p>Place the measuring fiche on the clip of track 38.</p> <p>Replace the injection computer if the XR25 is indicating a value of zero at no load (value correct if > 15 ms in no load).</p> <p>Replace the automatic transmission computer if the value is correct.</p>

AFTER REPAIR	<p>Erase the computer memory (G0**).</p> <p>Switch off the ignition then carry out a road test.</p> <p>Complete the operation by carrying out a check using the XR25.</p>
---------------------	---

<p style="margin: 0;">4</p> 	<p>Bargraph 4 RH side illuminated or flashing</p> <p><u>Kickdown switch circuit</u></p>	<p>Fiche n° 62</p>
--	--	--------------------

NOTES	<p>The kickdown switch circuit fault is present if the bargraph, after flashing, becomes permanently illuminated when the accelerator pedal is pressed (full-load).</p>
--------------	---

<p>This fault is related to the permanent earthing of track 18 of the computer connector or to an inconsistency between the status of the switch and the load value.</p>
<p>Look at the status of bargraph 15 LH side ("kickdown active").</p> <p>Is the kickdown permanently active when the accelerator pedal is not pressed?</p>

YES	<p>Disconnect the kickdown switch.</p> <ul style="list-style-type: none"> - If bargraph 15 LH side extinguishes, check the operation and mounting of the kickdown switch (contact normally open). Replace it if necessary. - If bargraph 15 LH side remains illuminated, ensure the insulation in relation to earth of the connection between track 18 of the computer connection and track 1 of the kickdown switch connector.
------------	---

NO	<p>Accelerate slowly and check the load value at #12 when bargraph 15 LH side illuminates.</p> <p>If the value is not greater than 61 % when the kickdown switch becomes active a consistency check will illuminate bargraph 4 RH side.</p> <ul style="list-style-type: none"> - Check the accelerator control and the adjustment of the cable. - Check the conformity of the injection potentiometer.
-----------	---

AFTER REPAIR	<p>Erase the computer memory (G0**).</p> <p>Switch off the ignition then carry out a road test.</p> <p>Complete the operation by carrying out a check using the XR25.</p>
---------------------	---

<p style="margin: 0;">4</p> 	<p>Bargraph 4 LH side illuminated or flashing</p> <p><u>Selector lever position information</u></p>	<p>Fiche n° 62</p>
--	--	--------------------

NOTES	<p>The fault is present if the bargraph, when flashing, becomes permanently illuminated when the selector lever is moved from position P to position 1 (keeping the lever in each position for a few seconds).</p>
--------------	--

Check the mounting of the multi-function switch on the automatic transmission and the adjustment of the control.

With the ignition switched off, disconnect the 10 track multifunction switch then check/ensure the presence of **+after ignition feed** on track 1 of the 10 track connector, wiring side.
 For every locked position of the selector lever, check each continuity and insulation which should be ensured (see table below)

Lever locked position	Continuity ensured	Insulation ensured
P	Track 1 / Track 3 Track 6 / Track 7	Tracks 2, 4 and 5 / Track 1 Track 8 / Track 9
R	Track 1 / Track 4 Track 8 / Track 9	Tracks 2, 3 and 5 / Track 1 Track 6 / Track 7
N	Track 1 / Track 5 Track 6 / Track 7	Tracks 2, 3 and 4 / Track 1 Track 8 / Track 9
D	Tracks 2, 3 and 5 / Track 1	Track 4 / Track 1 Track 8 / Track 9 Track 6 / Track 7
2	Tracks 2, 4 and 5 / Track 1	Track 3 / Track 1 Track 8 / Track 9 Track 6 / Track 7
1	Tracks 2, 3 and 4 / Track 1	Track 5 / Track 1 Track 8 / Track 9 Track 6 / Track 7

If an insulation or continuity is not ensured, replace the multifunction switch (refer to the replacement method).

If the multifunction switch is not faulty, ensure the continuity and insulation in relation to **12 volts** of the following connections:

- Between track **9** of the computer connection and **track 4** of the 10 track connector, wiring side.
- Between track **8** of the computer connection and **track 5** of the 10 track connector, wiring side.
- Between track **36** of the computer connection and **track 2** of the 10 track connector, wiring side.
- Between track **37** of the computer connection and **track 3** of the 10 track connector, wiring side.

Also ensure the insulation between all these connections.

AFTER REPAIR	<p>Erase the computer memory (G0**). Switch off the ignition then carry out a road test. Complete the operation by carrying out a check using the XR25.</p>
---------------------	---

<p style="margin: 0;">6</p> 	<p>Bargraph 6 RH side illuminated or flashing</p> <p><u>Engine torque information</u></p>	<p>Fiche n° 62</p>
---	--	--------------------

NOTES	<p>The torque information circuit fault is present if the bargraph, when flashing, becomes permanently illuminated with the engine running at more than 2000 rpm.</p>
--------------	---

<p>Ensure the continuity and insulation of the connection between track 39 of the AT computer connection and track 6 of the injection computer connection.</p> <p>Check the injection and AT computer connections.</p>
<p>Check the condition of the wiring and the conformity of its routing (risk of signal interference).</p> <p>Also check the conformity and condition of the high voltage circuits.</p>
<p>Disconnect the AT computer, then remove the plastic closing cover from its connector to gain access to the rear of the connector clips.</p> <p>Reconnect the AT computer.</p> <p>Set the XR25 to pulse detection mode (function G, terminal Vin).</p> <p>Start the engine.</p> <p>Place the measuring probe on the clip of track 39 of the AT computer connection.</p> <p>Replace the injection computer if the XR25 indicates a zero value (value correct at idle speed: approximately 7 ms).</p> <p>Replace the automatic transmission if the value is correct.</p>

AFTER REPAIR	<p>Erase the computer memory (G0**).</p> <p>Switch off the ignition then carry out a road test.</p> <p>Complete the operation by carrying out a check using the XR25.</p>
---------------------	---

<p style="margin: 0;">7</p> 	<p>Bargraph 7 LH side flashing <u>AT output speed sensor circuit</u></p>	<p>Fiche n° 62</p>
--	--	--------------------

NOTES	<p>The AT output speed sensor circuit fault is present if the bargraph illuminates during a road test (with gear change at an engine speed > 3000 rpm).</p>
--------------	--

Switch off the ignition, disconnect the 16 track connector on the automatic transmission and measure the AT output speed sensor resistance between **tracks 1 and 2**, AT side.

If the resistance measured is not approximately **700 ohms < R < 1300 ohms**, carry out the same measurement directly on the 2 track sensor connector.

- If the resistance is not correct to specification, replace the sensor.
- If the sensor resistance is correct, repair or replace the wiring concerned.

Check the computer and 16 track connector connections.

If the connections are correct, check and ensure the continuity and insulation of the following connections:

- Between track **42** of the computer connection and **track 1** of the 16 track connector.
- Between track **14** of the computer connection and **track 2** of the 16 track connector.

Also ensure the insulation between these two connections.

If all the checks are correct, reconnect the computer connector and 16 tracks on the AT, switch on the ignition, then erase the computer fault memory.

Exit fault finding mode (**G13***) and switch off the ignition.

If the fault reappears during a road test, replace the AT output speed sensor.

Erase the computer fault memory at the end of the operation.

AFTER REPAIR	<p>Erase the computer memory (G0**).</p> <p>Switch off the ignition then carry out a road test.</p> <p>Complete the operation by carrying out a check using the XR25.</p>
---------------------	---



<p style="margin: 0;">8</p> 	<p>Bargraph 8 LH side flashing <u>Turbine speed sensor circuit</u></p>	<p>Fiche n° 62</p>
---	--	--------------------

NOTES	<p>The turbine speed sensor circuit fault is present if the bargraph illuminates during a road test (with gear change at an engine speed > 3000 rpm).</p>
--------------	--

Switch off the ignition, disconnect the 16 track connector on the automatic transmission and measure the turbine speed sensor resistance between **tracks 15 and 16** sensor side.

If the resistance measured is not approximately **700 ohms < R < 1300 ohms**, carry out the same measurement directly on the 2 track sensor connector.

- If the resistance is not correct to specification, replace the sensor.
- If the sensor resistance is correct, repair or replace the wiring concerned.

Check the computer and 16 track connector connections.

If the connections are correct, check and ensure the continuity and insulation of the following connections:

- Between track **16** of the computer connection and **track 15** of the 16 track connector.
- Between track **44** of the computer connection and **track 16** of the 16 track connector.

Also ensure the insulation between these two connections.

If all the checks are correct, reconnect the computer connector and the 16 tracks on the AT, switch on the ignition, then erase the computer fault memory.

Exit fault finding mode (**G13***) and switch off the ignition.

If the fault reappears during a road test, replace the turbine speed sensor.

Erase the computer fault memory at the end of the operation.

AFTER REPAIR	<p>Erase the computer memory (G0**).</p> <p>Switch off the ignition then carry out a road test.</p> <p>Complete the operation by carrying out a check using the XR25.</p>
---------------------	---

<p style="margin: 0;">9</p> 	<p>Bargraph 9 LH side flashing</p> <p><u>Clutch overlap</u></p>	<p>Fiche n° 62</p>
---	--	--------------------

NOTES	<p>Deal with any other illuminated bargraphs first.</p>
--------------	---

Erase the computer memory using command **G0****. Switch the ignition off then on again to reinitialise the computer. Carry out a road test changing up and down through all the gears.

If the "clutch overlap" fault reappears, replace the hydraulic distributor and the 6 solenoid valves.

If the fault reappears, replace the automatic transmission.

AFTER REPAIR	<p>Erase the computer memory (G0**).</p> <p>Switch off the ignition then carry out a road test.</p> <p>Complete the operation by carrying out a check using the XR25.</p>
---------------------	---

<p>10</p> <hr style="border: 0.5px solid black;"/> <div style="border: 1px solid black; width: 30px; height: 20px; background-color: black; margin: 0 auto;"></div> <hr style="border: 0.5px solid black;"/>	<p>Bargraph 10 RH side flashing Fiche n° 62</p> <p><u>Gear change consistency</u> (comparison of AT output and input speeds at gear changes)</p>
---	--

NOTES	<p>Deal with any other illuminated bargraphs first. The speed measurement fault is present if the bargraph illuminates during a road test (changing up and down through all the gears at high load).</p>
--------------	--

<ul style="list-style-type: none"> - Check the conformity of the automatic transmission using command G70*. Computers which are correct to specification: 77 00 109 385.
<ul style="list-style-type: none"> - Check the AT output speed sensor : <ul style="list-style-type: none"> * Measure the resistance of the sensor between tracks 1 and 2 of the 16 track connector on the automatic transmission. Replace the sensor if its resistance is not approximately 700 ohms < R < 1300 ohms.
<ul style="list-style-type: none"> - Check the turbine speed sensor: <ul style="list-style-type: none"> * Measure the resistance of the sensor between tracks 15 and 16 of the 16 track connector on the automatic transmission. Replace the sensor if its resistance is not approximately 700 ohms < R < 1300 ohms.
<p>Check the connections on the automatic transmission and the 16 track connector. Carry out the necessary operations.</p>
<p>Erase the computer memory (G0**), switch off the ignition then carry out a road test to determine at which gear change the fault is stored (be sure to go through all gear changes, up and down).</p> <p>If the fault reappears, check the consistency and the stability of the AT output speed information at #05 and turbine speed at #07 in the conditions under which the fault was detected.</p> <ul style="list-style-type: none"> - If the speeds are not stable (abnormal fluctuation of the value), carry out investigations to eliminate the interference. - If the fault reappears, and the speeds are stable when the fault is detected, replace the hydraulic distributor and the solenoid valves. - If the fault reappears, replace the automatic transmission (internal AT problem).

AFTER REPAIR	<p>Erase the computer memory (G0**). Switch off the ignition then carry out a road test. Complete the operation by carrying out a check using the XR25.</p>
---------------------	---

<p style="margin: 0;">10</p> <hr style="border: 0; border-top: 1px solid black; margin: 5px 0;"/> <div style="background-color: black; width: 20px; height: 15px; margin: 0 auto;"></div> <hr style="border: 0; border-top: 1px solid black; margin: 5px 0;"/>	<p>Bargraph 10 LH side flashing</p> <p><u>Over-revving</u></p>	<p>Fiche n° 62</p>
---	---	--------------------

NOTES	<p>Deal with any other illuminated bargraphs first.</p>
--------------	---

<p>This fault is detected when the engine speed or the turbine speed exceeds 7200 rpm</p> <p>Enter injection computer fault finding mode to check whether an engine speed sensor fault has been detected.</p> <p>If a fault is declared, apply the associated fault finding in the relevant documentation. After the operation on the injection, return to automatic transmission fault finding to erase the computer fault memory.</p> <p>Also check the engine cut-off speed (limiting of the engine speed at full-load).</p>
<ul style="list-style-type: none"> - Check the turbine speed sensor: Measure the resistance of the sensor between tracks 15 and 16 of the 16 track connector on the automatic transmission. Replace the sensor if its resistance is not approximately 700 ohms < R < 1300 ohms. <p>Check the connections for the automatic transmission and the 16 track connector. Carry out the necessary operations.</p>
<p>Erase the computer memory (G0**), switch off the ignition then carry out a road test to check the consistency and the stability of the engine speed information at #06 and turbine speed on #07.</p> <ul style="list-style-type: none"> - If the speeds are not stable (abnormal fluctuation of the value), carry out investigations to eliminate the interference.

AFTER REPAIR	<p>Erase the computer memory (G0**). Switch off the ignition then carry out a road test. Complete the operation by carrying out a check using the XR25.</p>
---------------------	---

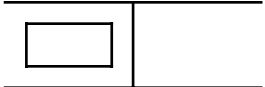
<p style="margin: 0;">14</p> 	<p>Bargraph 14 LH side</p> <p><u>Poor grip selector</u></p>	<p>Fiche n° 62</p>
--	--	--------------------

NOTES	<p>The poor grip selector is a push-button (non locking). The illumination of bargraph 14 LH side indicates that this operating mode has been activated.</p>
--------------	--

Bargraph 14 LH side always extinguished

- Check the operation of the selector switch (contact between **tracks B1 and B2** of the connector).
- Ensure the presence of earth on track **B1** of the selector connector.
- Check the condition of the connections on the selector, the computer and the intermediate connection (engine / dashboard) **R262** in the passenger compartment connection unit.
- Ensure the continuity between track **B2** of the mode selector connector and **track 12** of the computer connection.

Bargraph 14 LH side always illuminated

Disconnect the poor grip mode selector button.

- If **bargraph 14 LH side extinguishes**, check the operation of the selector button (contact normally open between **tracks B1** and **B2** of the connector). Replace it if necessary.
- If **bargraph 14 LH side remains illuminated**, ensure the insulation in relation to earth of the connection between track **12** of the computer connection and **track B2** of the poor grip mode selector button connector.

AFTER REPAIR

Ensure that the bargraph operation is consistent.

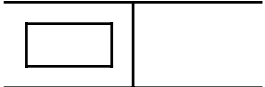
<p style="margin: 0;">15</p> 	<p>Bargraph 15 LH side Fiche n° 62</p> <p><u>Kickdown</u> (bargraph illuminated in "full load" position)</p>
--	--

NOTES	Deal with bargraph 4 RH side first ("kickdown switch fault") if it is illuminated.
--------------	--

Bargraph 15 illuminated on LH side at no load

Disconnect the switch connector.

- If **bargraph 15 LH side remains illuminated**: Ensure the insulation in relation to earth of the connection between track **18** of the computer connection and the switch connector (**track 1**).
- If **bargraph 15 LH side extinguishes**: Check mounting, adjustment and operation of the kickdown switch and replace it if it is faulty (if the contact is permanently closed).

Bargraph 15 extinguished on LH side at full load

- Check the adjustment of the accelerator cable (cable too taut).
- Check the operation and mounting of the kickdown switch (contact closed).
- Ensure the presence of earth on the switch connector wiring side (**track 2**).
- Check the condition of the connections on the switch, the computer and the intermediate connection (engine/ dashboard) **R262** in the passenger compartment connection unit.
- Ensure the continuity between the switch connector and **track 18** of the computer connection.

AFTER REPAIR

Ensure that the bargraph operation is consistent.

<p style="margin: 0;">16</p> 	<p>Bargraphs 16 RH side and LH side</p> <p><u>Brake switch</u></p>	<p>Fiche n° 62</p>
--	---	--------------------

NOTES	<p>The computer only takes the information from the brake switch into account when its correct operation is confirmed.</p> <p>When the ignition is switched on, bargraph 16 RH side is illuminated and should extinguish when the brake pedal is pressed for the first time (programming function").</p>
--------------	--

Bargraph 16 illuminated permanently on LH side

- Check the adjustment of the brake switch and that it is operating correctly (continuity between **tracks 1 and 2**, pedal not pressed).
- Check and ensure the presence of **+after ignition feed on track 1** of the switch connector.
- Check the condition of the connections on all of the "brake information" line connections.
- Ensure the continuity of the connection between track **2** of the switch connector and **track 10** of the computer connection. Intermediate connection: **R262** (engine/dashboard) in the passenger compartment connection unit.

Bargraph 16 extinguished on LH side when braking

Disconnect the brake switch connector.

- If **bargraph 16 LH side does not illuminate** (and 16 RH side remains illuminated): Ensure the insulation in relation to **12 volts** of the connection between track **10** of the computer connection and **track 2** of the brake switch connector.
- If **bargraph 16 LH side illuminates** (and 16 RH side extinguishes):
 Check the mounting, adjustment and operation of the brake switch (contact open between **terminals 1 and 2**). Replace it if it is faulty.

AFTER REPAIR

Ensure that the bargraph operation is consistent.

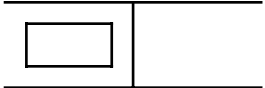
<p>17</p> 	<p>Bargraph 17 LH side Fiche n° 62</p> <p><u>Fault warning light</u></p> <p>XR25 aid: BG 17 LH side illuminated if fault warning light on the instrument panel is illuminated</p>
---	--

NOTES	None
--------------	------

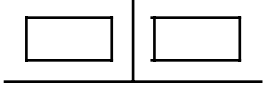
<p>18</p> 	<p>Bargraphs 18 RH side and LH side Fiche n° 62</p> <p><u>Sequence solenoid valves control</u></p> <p>XR25 aid: BG 18 LH side and/or RH side illuminated depending on gear engaged</p>
---	---

NOTES	None
--------------	------

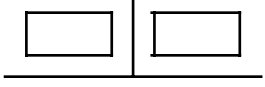
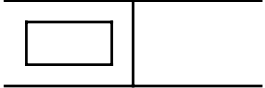
<p>19</p> 	<p>Bargraphs 19 and 20 RH side and LH side Fiche n° 62</p> <p><u>Computer configuration</u></p> <p>XR25 aid: BG 19 and 20 LH side and RH side illuminated depending on computer configuration</p>
<p>20</p> 	

NOTES	<p>BG 19 LH side : "Sport" configuration not operational for this application (there is no gear change mode selector). This operating mode is controlled by an auto-adaptive mode.</p> <p>BG 19 RH side : "With lever locking" configuration not operational for this application (this selector lever locking function will appear as the product develops).</p> <p>BG 20 LH side : "Without kickdown switch" configuration not operational for this application (current applications still have a kickdown switch).</p>
--------------	--



AFTER REPAIR	Ensure that the bargraph operation is consistent.
---------------------	---

AUTOMATIC TRANSMISSION

Fault finding - Checking conformity

23

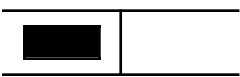
NOTES	Only carry out this conformity check after a complete check using the XR25 (no fault detected).
--------------	---

Order of operations	Function to be checked	Action	Bargraph	Display and Notes
1	Computer conformity	G70* #91		
2	Selector lever positions recognition	#01		<p>Check on the XR25 or on the instrument panel that all the selector lever positions are recognised.</p> <ul style="list-style-type: none"> - Check starting authorisation in P and N. - Check the operation of the reversing lights in R.
3	Brake switch	Press the brake pedal	<p>16</p> 	<p>Bargraph 16 RH side, illuminated when the ignition is switched on, should extinguish and 16 LH side should illuminate.</p>
4	Kickdown	Press the accelerator pedal fully	<p>15</p> 	
5	Poor grip operating mode	Press the selector	<p>14</p> 	<p>Bargraph 14 LH side illuminates and extinguishes when the selector button is pressed.</p> <p>The display on the instrument panel indicates this mode using an icon.</p>
6	3rd gear hold operating mode	Press the selector		<p>"D₃" on the instrument panel display.</p>

AUTOMATIC TRANSMISSION

Fault finding - Aid

REMINDER ABOUT FORWARD GEARS POSSIBLE DEPENDING ON THE POSITION OF THE SELECTOR LEVER AND THE OPERATING MODE SELECTED

	DRIVE	DRIVE+ under-drive (= 3 rd gear hold)	2	1
NORMAL	1 - 2 - 3 - 4	1 - 2 - 3	1 - 2	1
POOR GRIP	2 - 3 - 4 Starting in 2 nd 1 possible on kickdown	3 Starting in 3 rd 1 - 2 possible on kickdown	2 Starting in 2 nd 1 possible on kickdown	1

Special notes relating to the replacement of components

The AT LM0 computer uses auto-adaptive parameters to manage gear changes and the "Lock-up" function. These auto-adaptive values optimise the pressure and the time taken to fill the brakes and clutches depending on the mechanical/hydraulic specifications specific to each automatic transmission. Therefore, if any part which has an effect on these parameters is replaced, the stored values must be updated. The auto-adaptive values are reset to zero using XR25 command G80**. When command G80** has been used, it is important to carry out a road test enabling all gear changes, up and down, to be made several times to store the new values.

The auto-adaptive values must be reset to zero when the following parts are replaced:

- Hydraulic distributor.
- Torque converter.
- Solenoid valve.
- Complete automatic transmission.

AUTOMATIC TRANSMISSION

Fault finding - Aid (cont)

23

INFORMATION SHOWN ON THE XR25 DISPLAY IN #01:

The letter or digit to the right shows the position of the selector lever.
The characters to the left of the point represent the gear engaged.

Selector lever position	Ignition on, engine not running	Ignition on, engine running	Vehicle moving	Observations
P	n1.P	n1.P		
R	r.r	r.r	r.r	
N	n1.n	n1.n	n1.n to n4.n depending on vehicle speed	
D	d1.d	d1.d or d2.d in poor grip mode	d1.d d2.d d3.d d4.d	
D + under-drive	d1.3	d1.3 or d3.3 in poor grip mode	d1.3 d2.3 d3.3	
2	d1.2	d1.2 or d2.2 in poor grip mode	d1.2 d2.2	
1	d1.1	d1.1	d1.1	

AUTOMATIC TRANSMISSION

Fault finding - Customer complaints

23

NOTES

Only consult this customer complaint after a complete check using the XR25 and a conformity check.

INSTRUMENT PANEL FAULTS

- | | | |
|---|--|----------------|
| — | Illumination of the automatic transmission fault warning light with no fault detected by the XR25 | Chart 1 |
| — | No automatic transmission display on the instrument panel (selector lever position - operating mode) | Chart 2 |
| — | Loss of indication of P, N and D positions on the automatic transmission display on the instrument panel (position R, 2 and 1 indicated correctly) | Chart 3 |
| — | Engine speed not shown on the instrument panel (for vehicles equipped with rev-counter) | Chart 4 |

ENGINE STARTING FAULTS

- | | | |
|---|---|----------------|
| — | The starter motor does not cut in with the selector lever in position P and/or N | Chart 5 |
| — | The starter motor cuts in with the selector lever in a position other than P or N | Chart 6 |

GEAR CHANGE FAULTS

- | | | |
|---|--------------------------|----------------|
| — | Untimely gear changes | Chart 7 |
| — | No kickdown at full-load | Chart 8 |

AUTOMATIC TRANSMISSION OPERATING FAULTS

Chart 9

- No drive in forward and/or reverse
- Late engagement with engine racing followed by a knock on starting
- The vehicle advances sluggishly on starting
- Knocks, slipping or engine racing at gear changes
- No gear changes, vehicle locked in one gear
- Absence of one or more gears
-

OTHER FAULTS

- No communication between the computer and the XR25 **Chart 10**
- Reversing lights do not work (reverse gear works and the bulbs are good) **Chart 11**
- Oil underneath the vehicle **Chart 12**

Chart 1	ILLUMINATION OF THE AUTOMATIC TRANSMISSION FAULT WARNING LIGHT WITH NO FAULT DETECTED BY THE XR25
----------------	--

NOTES	Only consult this customer complaint after a complete check using the XR25 and a conformity check.
--------------	--

<p>Look for a short circuit to earth of the connection between track 25 of the AT computer connector and track 3 of the selector connector (AT display connection to the computer).</p> <p>This fault also results in the absence of the lever position and operating mode display.</p>

AFTER REPAIR	Carry out a road test then check using the XR25.
---------------------	--

Chart 2	NO AUTOMATIC TRANSMISSION DISPLAY ON THE INSTRUMENT PANEL (selector lever and operating mode position)
----------------	---

NOTES	Only consult this customer complaint after a complete check using the XR25 and a conformity check.
--------------	--

Ensure the continuity and insulation of the connection between **track 25** of the AT computer connector and **track 3** of the selector connector (AT display connection to the computer).

A short circuit to earth of this connection also results in the illumination of the automatic transmission fault warning light.

AFTER REPAIR	Carry out a road test then check using the XR25.
---------------------	--

Chart 3	LOSS OF INDICATION OF P, N AND D POSITION ON THE AUTOMATIC TRANSMISSION DISPLAY ON THE INSTRUMENT PANEL (positions R, 2 and 1 indicated correctly)
----------------	---

NOTES	Only consult this customer complaint after a complete check using the XR25 and a conformity check.
--------------	--

Ensure the insulation in relation to **12 volts** of the connection between **track 9** of the AT computer connector and **track 4** of the 10 track multifunction switch connector.

If the insulation is ensured, replace the multifunction switch.

AFTER REPAIR	Carry out a road test then check using the XR25.
---------------------	--

Chart 4	NO INDICATION OF ENGINE SPEED ON INSTRUMENT PANEL (FOR VEHICLES EQUIPPED WITH REV COUNTER)
----------------	---

NOTES	Only consult this customer complaint after a complete check using the XR25 and a conformity check.
--------------	--

Ensure the insulation of the connection between **track 40** of the AT computer connector, **track 43** of the injection computer and the instrument panel connector (instrument panel engine speed information connection).

AFTER REPAIR	Carry out a road test then check using the XR25.
---------------------	--

Chart 5	THE STARTER MOTOR DOES NOT CUT IN WITH THE SELECTOR LEVER IN POSITION P AND/OR N
----------------	---

NOTES	Only consult this customer complaint after a complete check using the XR25 and a conformity check.
--------------	--

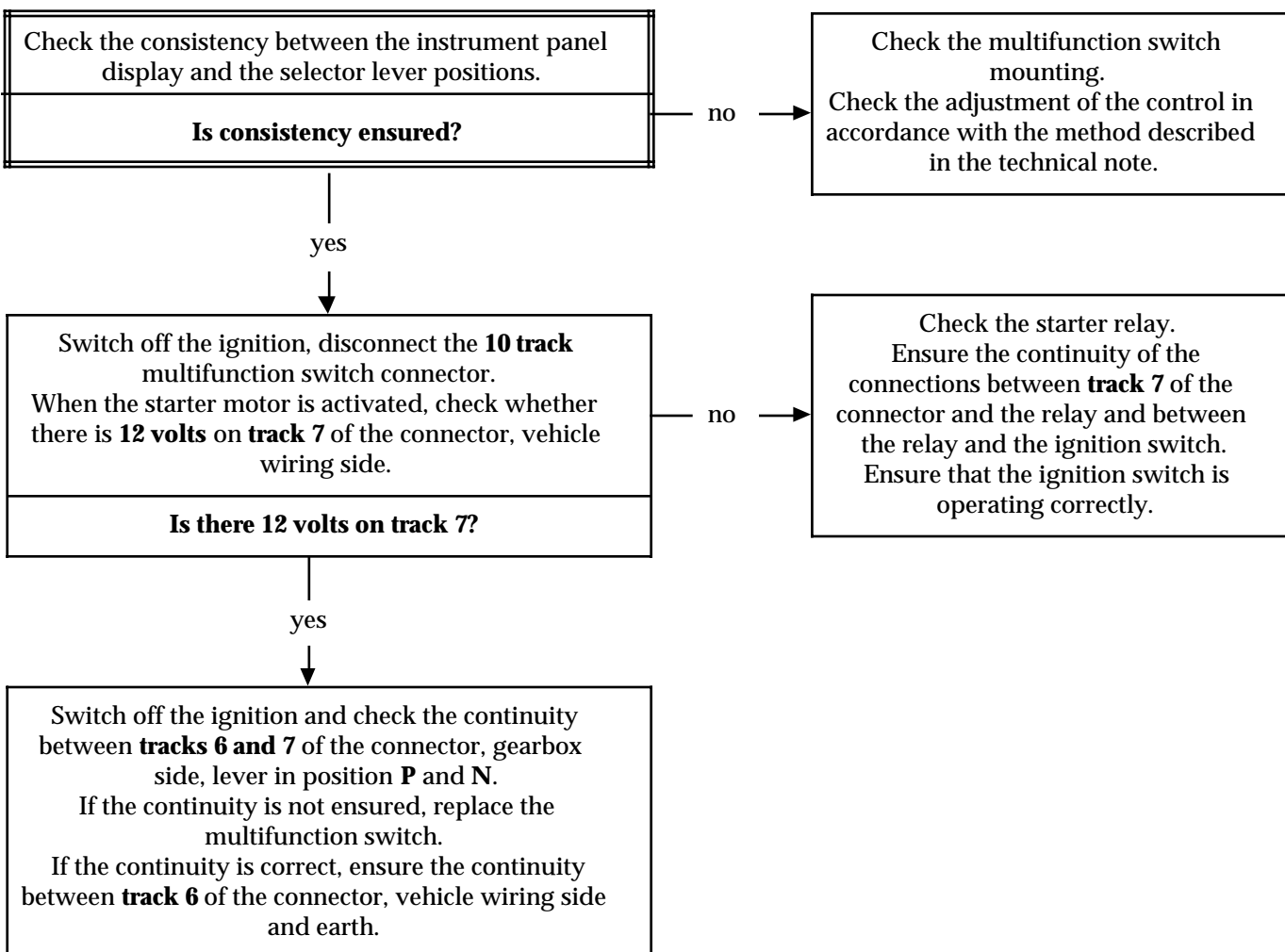

AFTER REPAIR	Carry out a road test then check using the XR25.
---------------------	--

Chart 6	THE STARTER MOTOR CUTS IN WITH THE SELECTOR LEVER IN A POSITION OTHER THAN P OR N
---------	---

NOTES	Only consult this customer complaint after a complete check using the XR25.
--------------	---

Switch off the ignition, disconnect the 10 track multifunction switch connector.

Check the operation of the **P/N** switch:

- Continuity between **tracks 6 and 7** lever in position **P** and **N**.
- Insulation between **tracks 6 and 7** lever in position other than **P** and **N**.

Replace the multifunction switch if there is a fault.

If the **P/N** switch operates correctly, ensure the insulation in relation to earth of the connection between **track 7** of the connector vehicle wiring side and **track 2** of the starter relay mounting.

AFTER REPAIR	Carry out a road test then check using the XR25.
---------------------	--

Chart 7	UNTIMELY GEAR CHANGES
----------------	------------------------------

NOTES	Only consult this customer complaint after a complete check using the XR25 and a conformity check.
--------------	--

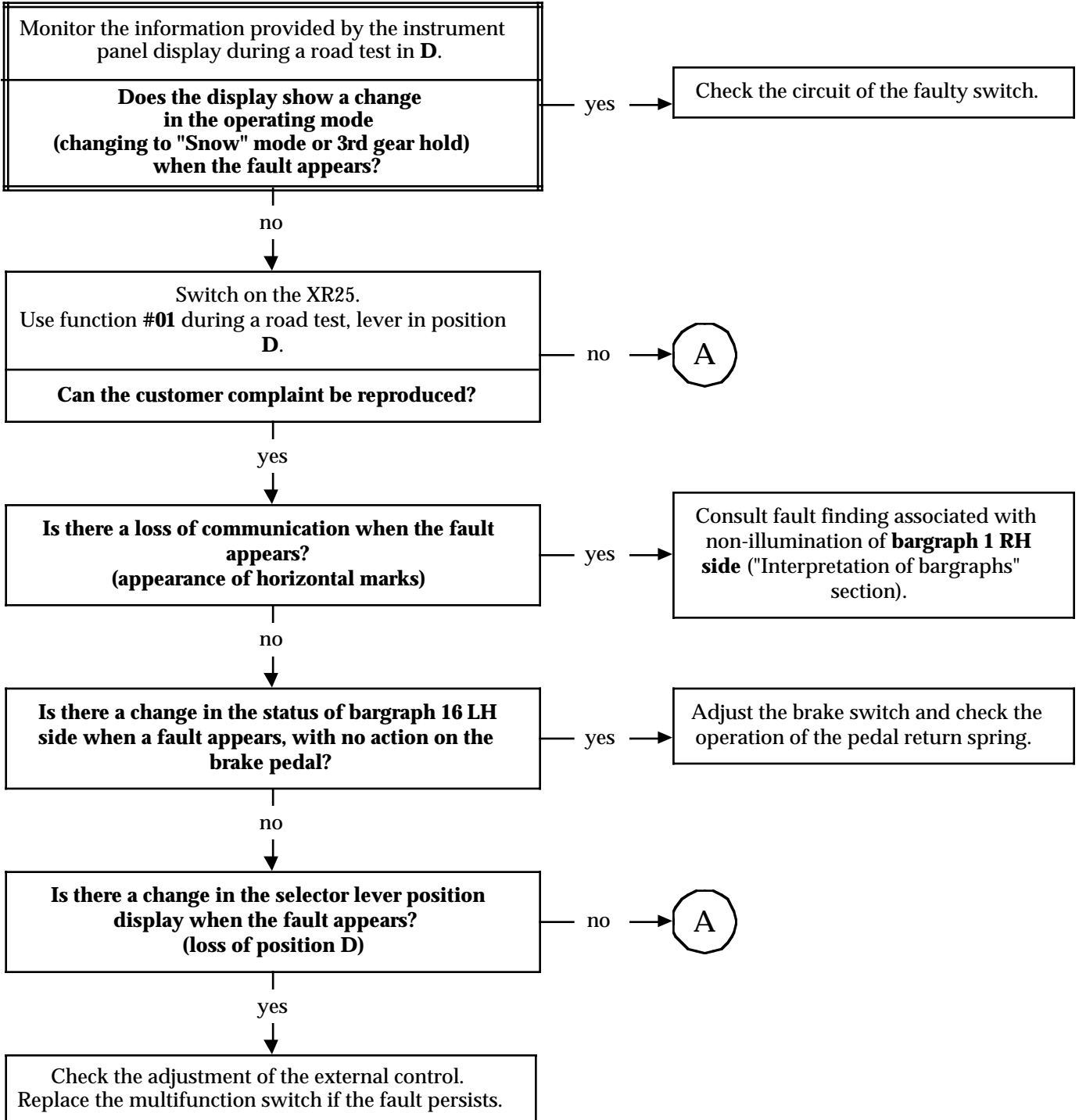

AFTER REPAIR	Carry out a road test then check using the XR25.
---------------------	--

Chart 7 Cont	
-------------------------------	--

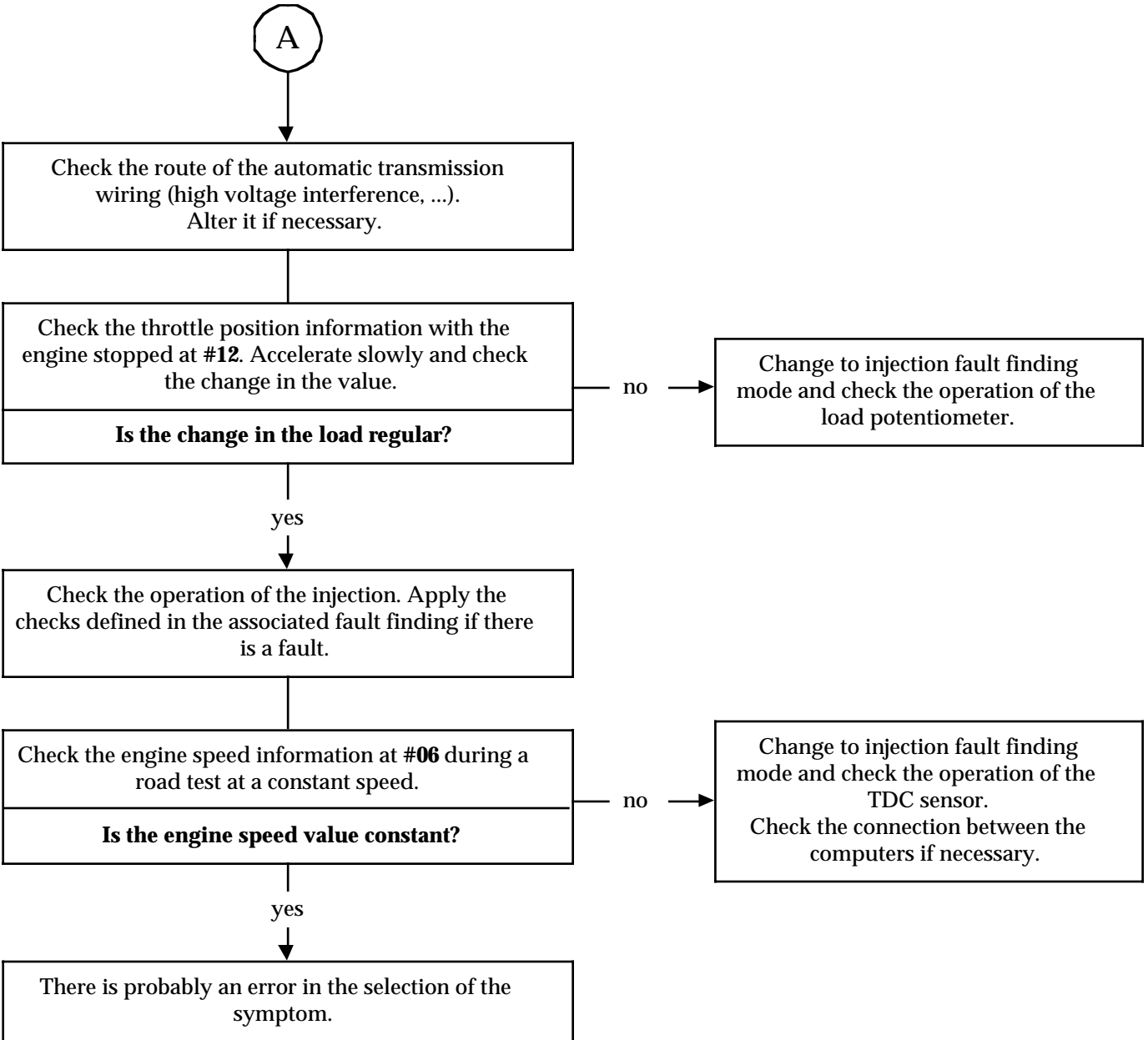

AFTER REPAIR	Carry out a road test then check using the XR25.
---------------------	--

Fault finding - Fault charts

Chart 8	NO KICKDOWN AT FULL-LOAD
----------------	---------------------------------

NOTES	Only consult this customer complaint after a complete check using the XR25 and a conformity check.
--------------	--

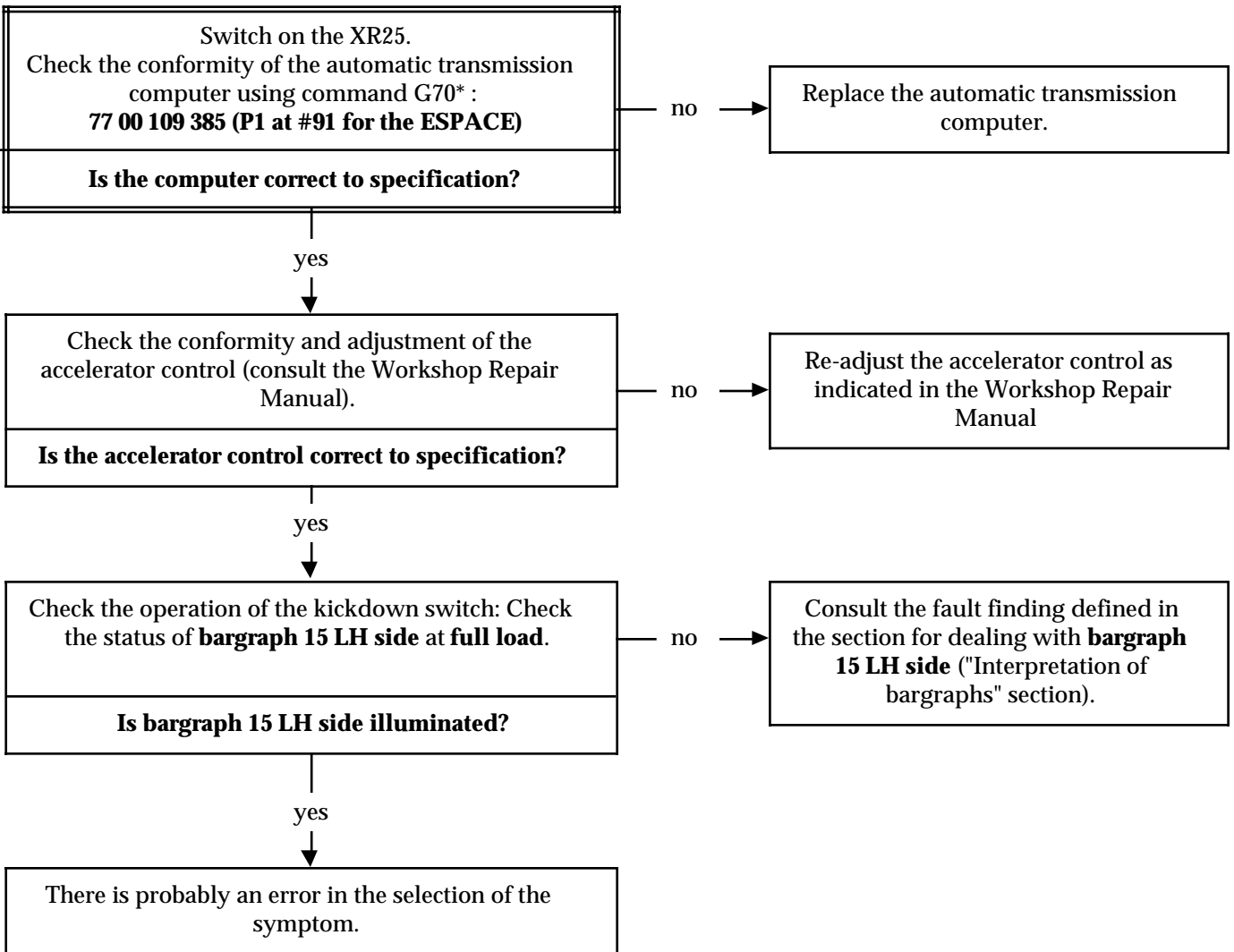

AFTER REPAIR	Carry out a road test then check using the XR25.
---------------------	--

Chart 9	AUTOMATIC TRANSMISSION OPERATING FAULTS
----------------	--

NOTES	Only consult this customer complaint after a complete check using the XR25 and a conformity check.
--------------	--

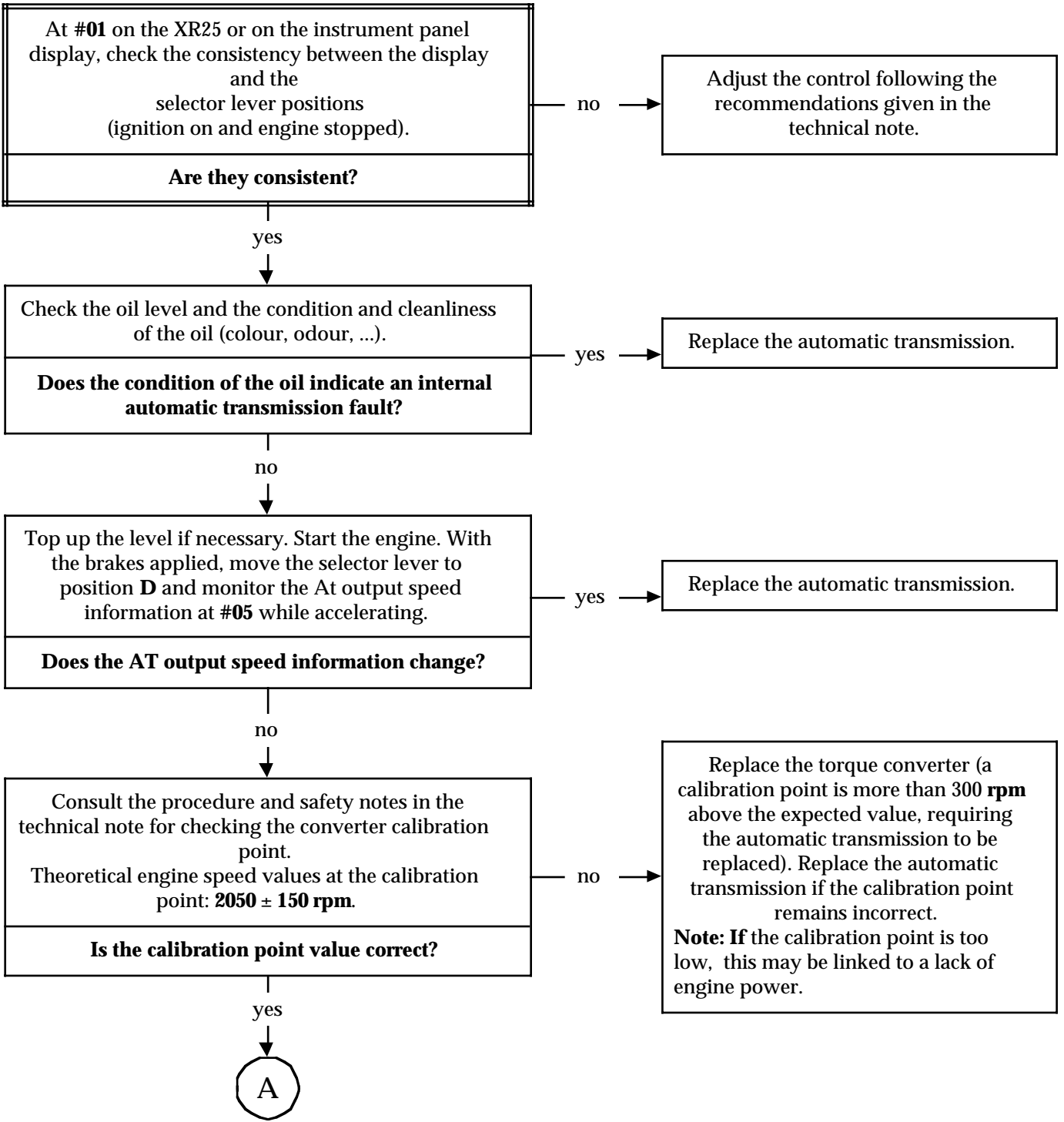

AFTER REPAIR	Carry out a road test then check using the XR25.
---------------------	--

Chart 9 Cont	
-------------------------------	--

A

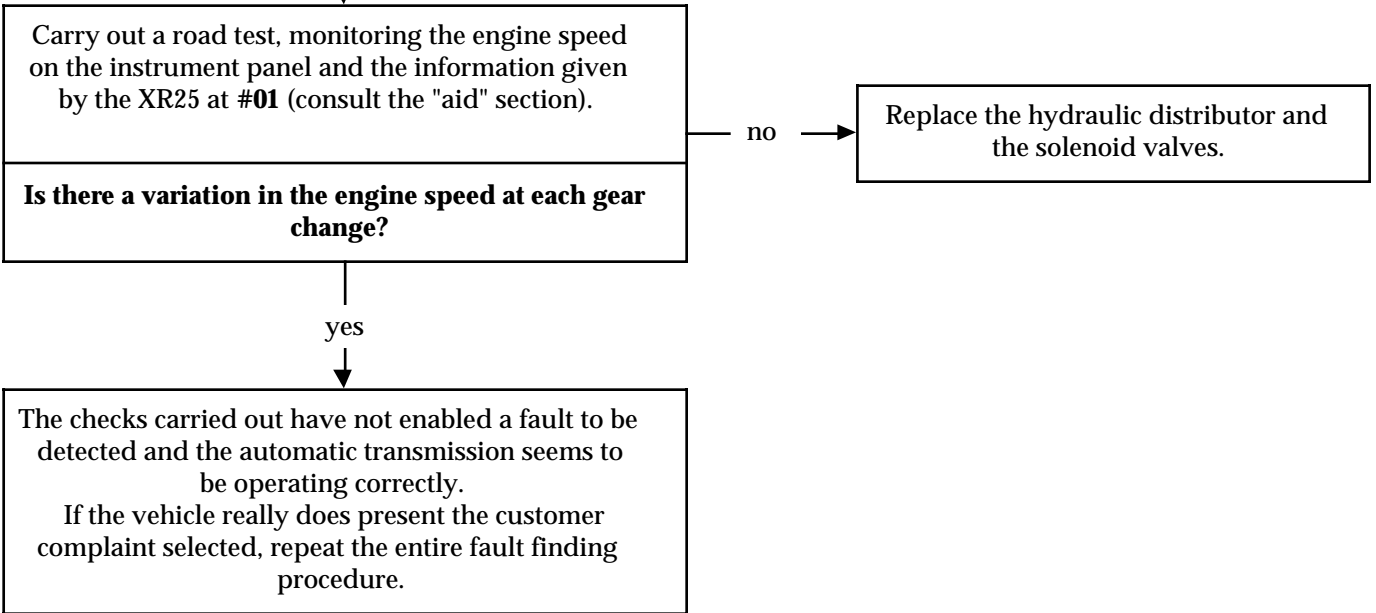

AFTER REPAIR	Carry out a road test then check using the XR25.
---------------------	--

Chart 10	NO COMMUNICATION BETWEEN THE COMPUTER AND THE XR25
-----------------	---

NOTES	None
--------------	------

Ensure that the XR25 is not the cause of the fault by trying to communicate with a computer on another vehicle. If the XR25 is not at fault and dialogue is not established with another computer on the same vehicle, a faulty computer may be disrupting fault finding lines **K** and **L**. Locate the faulty computer by disconnecting each computer in turn.

Check that the ISO selector is in position **S8**, that you are using XR25 cassette 18 and the correct access code.

Check the battery voltage and carry out the operations necessary to obtain the correct voltage (**9 volts < U battery < 16 volts**).

Check whether the **5 A** AT fuse on the passenger compartment connection unit has blown (if a **5 A fuse** blows again after it has been replaced, first look for a short circuit to earth of one of the 4 multifunction switch lines or a short circuit to 12 volts of the P/N/E connection between the injection and AT computers). If the fuse blows when the kickdown switch or the "poor grip" or "3rd gear hold" selectors are operated, look for a short circuit to **12 volts** of the circuits in question.

Check the connection and condition of the computer connector connections and the engine / dashboard connections (in the passenger compartment connection unit **R262 clear connector, clear track A8**).

Check that the computer is correctly fed:

- **Earth on tracks 28 and 34.**
- **+after ignition feed on tracks 31 and 54.**

Check that the diagnostic socket is correctly fed:

- **Earth on track 5** of the 16 track diagnostic socket.
- **+before ignition feed on track 16** of the 16 track diagnostic socket.

Check and ensure the continuity and insulation of the lines connecting the diagnostic socket/ computer:

- Between **track 47** of the computer connector and **track 15** of the 16 track diagnostic socket.
- Between **track 50** of the computer connector and **track 7** of the 16 track diagnostic socket.

If dialogue is still not established after these various checks, replace the computer and erase the fault memory at the end of the operation.

AFTER REPAIR	When communication has been established, deal with any illuminated fault bargraphs.
---------------------	---

Chart 11	REVERSING LIGHTS DO NOT WORK (reverse gear works and the bulbs are good)
-----------------	---

NOTES	Only consult this customer complaint after a complete check using the XR25 and a conformity check.
--------------	--

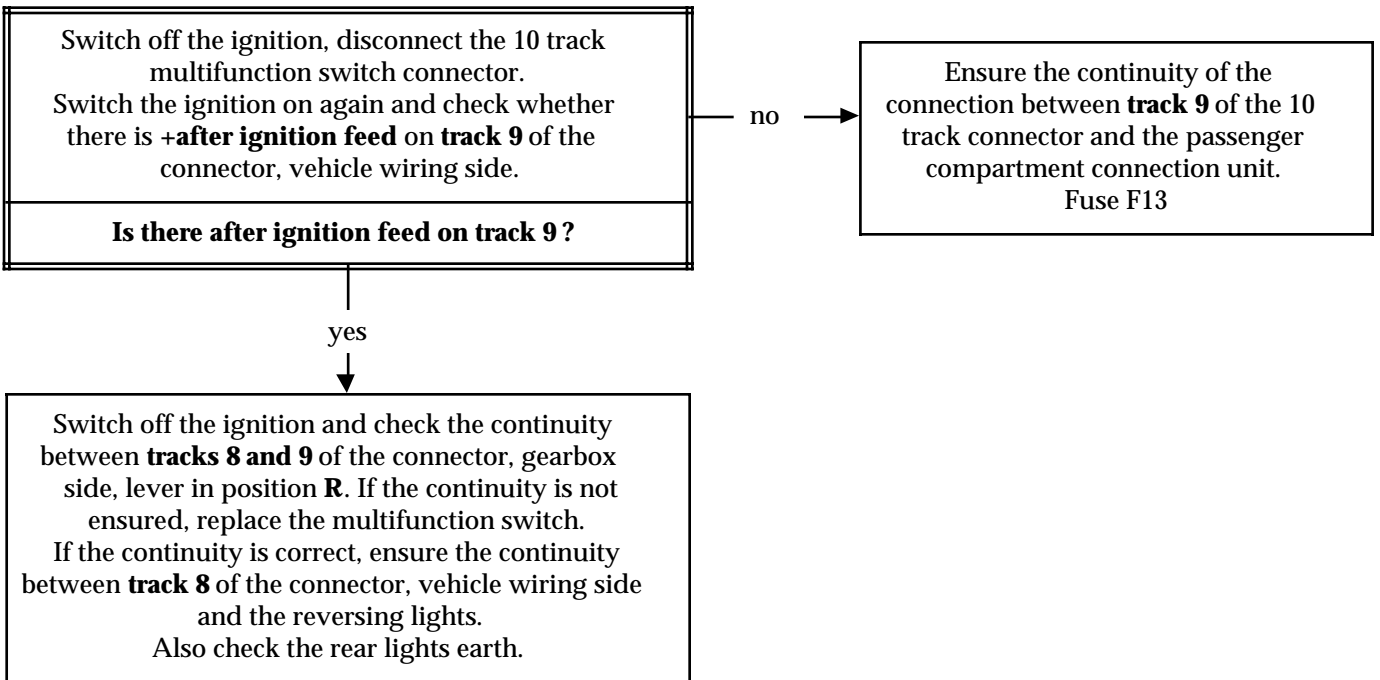

AFTER REPAIR	When communication has been established, deal with any illuminated fault bargraphs.
---------------------	---

Chart 12	OIL UNDERNEATH THE VEHICLE
-----------------	-----------------------------------

NOTES	Only consult this customer complaint after a complete check using the XR25 and a conformity check.
--------------	--

Wash the automatic transmission, top up the oil level following the method described in the technical note, sprinkle with chalk and locate the origin of the leak.
Deal with the origin of the leak and replace the faulty components.
Check the oil level.

AUTOMATIC TRANSMISSION CONTROL

REMOVAL

Disconnect the battery.

In the passenger compartment:

Remove :

- the ashtray,
- the steering wheel half cowlings,
- the lower right and left hand consoles,
- the console under the steering wheel (disconnect the lighting rheostat),
- the panel under the knee, with a roll pin punch pull the centre rod from each pin and keep it, or remove the rivets depending on the version.
- the driver's fabric door trim,
- the automatic transmission repeater surround,
- the steering assembly surround and disconnect the automatic transmission surround,
- the passenger air bag fabric cover without detaching it from its strap,

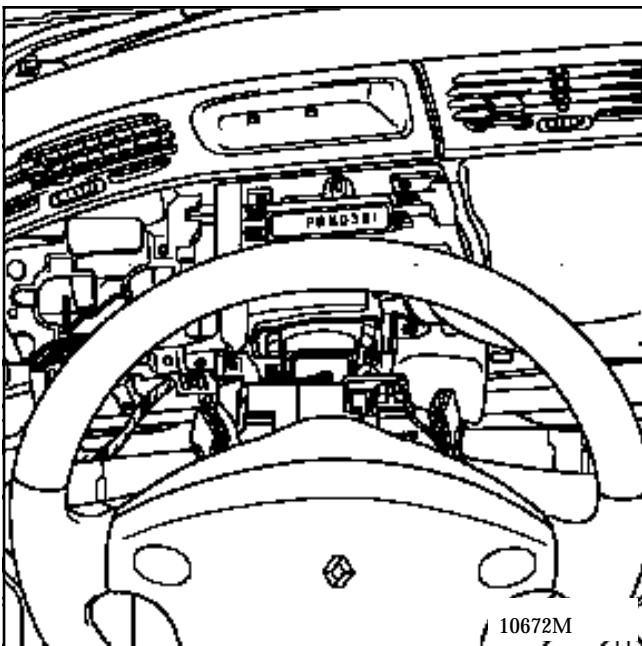

Remove the cassette player if one is fitted.

Pull up the carpet from the bottom of the storage compartment and remove the 2 bolts + 1 side bolt.

Remove the wide headed bolts from the cover hinge.

Remove the storage compartment by disconnecting the light and unclipping the antenna and radio remote control cables.

Disconnect the gear change safety cable by removing the clip.

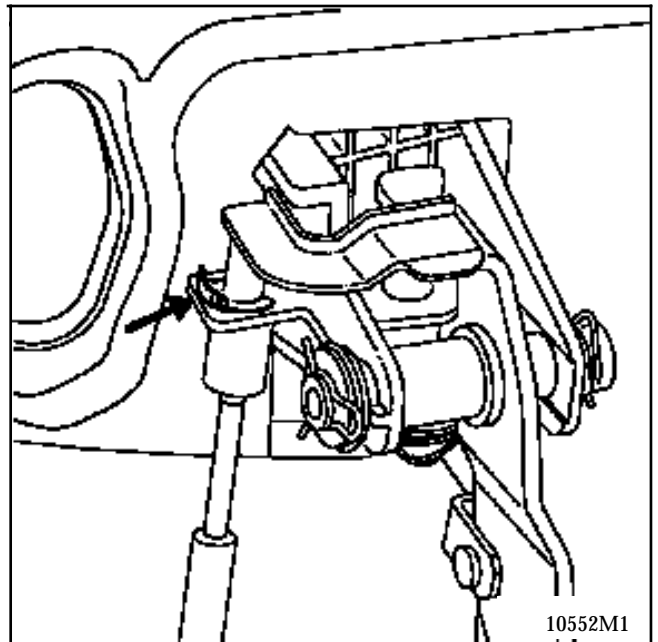

NOTE:

The cable acts on a lever which locks the gear selector lever in the "Parking" position when the brake pedal is not applied.

Disconnect the multiselector wiring loom at the control.

Put the gear lever in the "Drive" position (so that it can be adjusted, if necessary).

Remove the control (4 bolts).

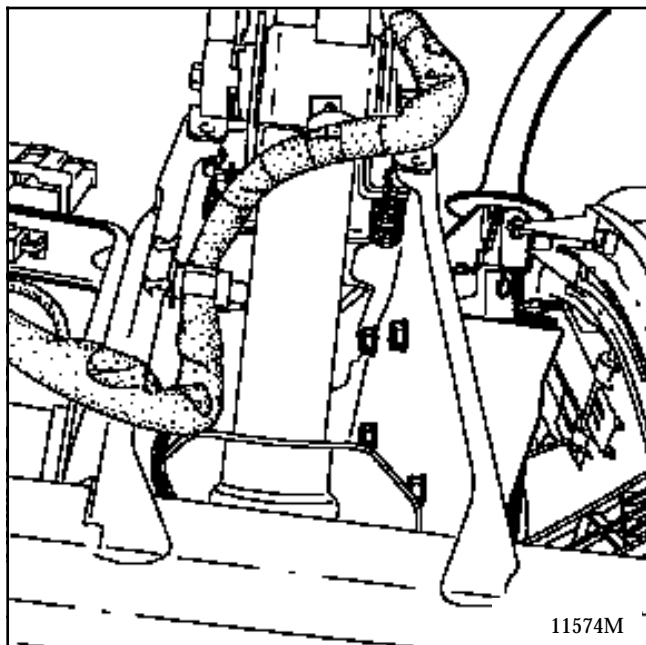

Engine compartment side:

Remove:

- the battery,
- the air filter assembly.

Disconnect the brake servo pressure pipe.

Slacken the PAS pipe mounting bolt and detach the pipe mounting assembly.

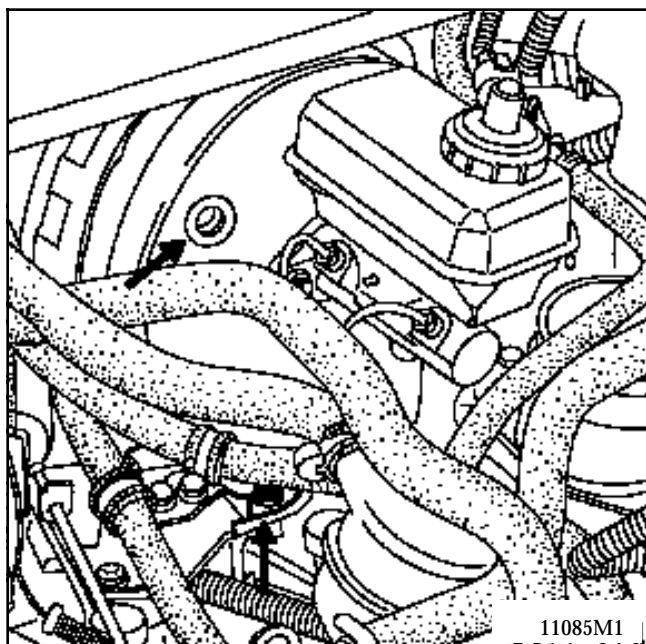

Unhook the wiring loom from the brake servo mounting to allow the cable to pass through.

Unclip the control rod.

Attach a wire guide to the end of the control to be removed, AT side to allow the wiring for the new control to be laid correctly.

Remove the clip and remove the control by releasing the cable (this operation requires two people).

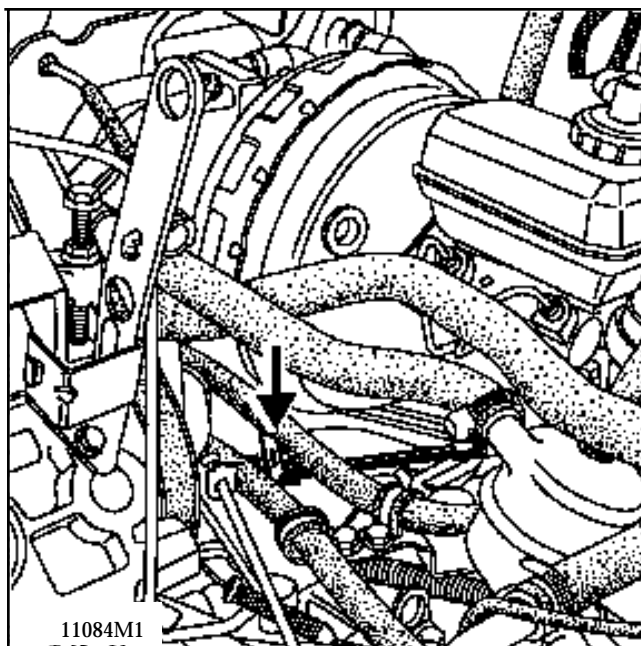

REFITTING

Fit the control with its cable.

Before anything else is refitted, check that it changes position correctly ("gears") and that they are blocked where appropriate and that they correspond with the repeater.

Otherwise, replace the control.

Adjustment:

Use two people to carry out this operation.

- If it has not already been done, put the gear selector control lever in the Drive position.

Also place the transmission lever in the drive position:

First push the ball joint to the right hand side (vehicle) and count that it locks 3 times before reaching the "Drive" position. The operation may also be carried out in terms of the "Park" position but the locking sensation is less clear.

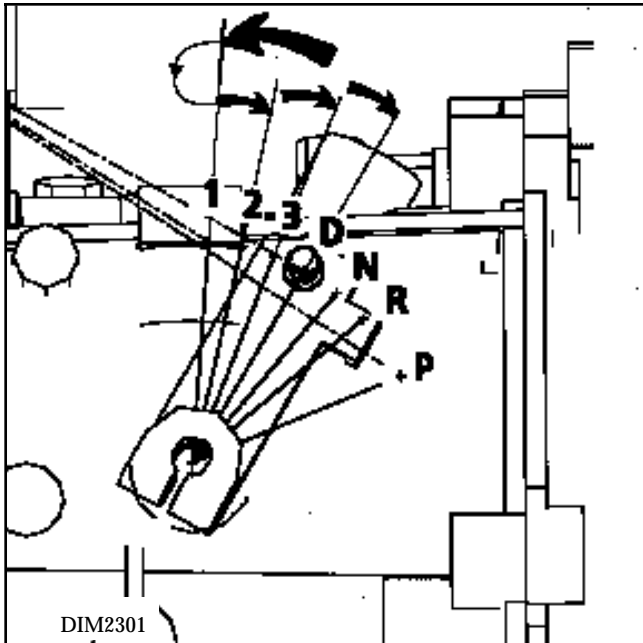

- Slacken the adjusting bolt (1) at the end of the cable, transmission side. Never touch the cable sleeve stop clip.

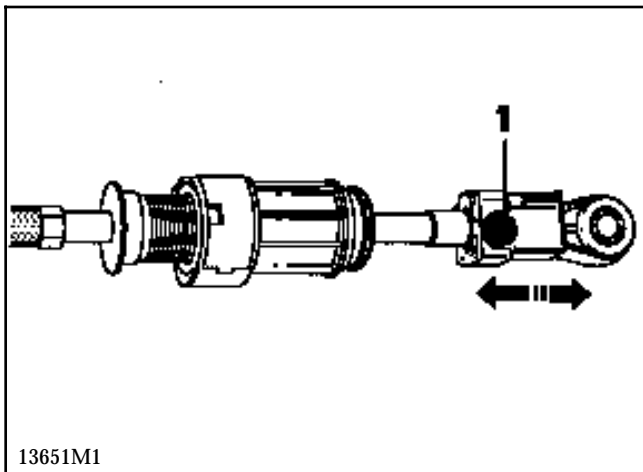

- Place a **1.9 mm** shim between the control lever finger and the tooth (2).
- Maintain a constant pressure on the control lever to hold the shim (1 person in the vehicle).
- Retighten the cable adjusting bolt (1) at the driveshaft by ensuring the lever locks firmly.

Tightening torque: **0.8 daN.m**

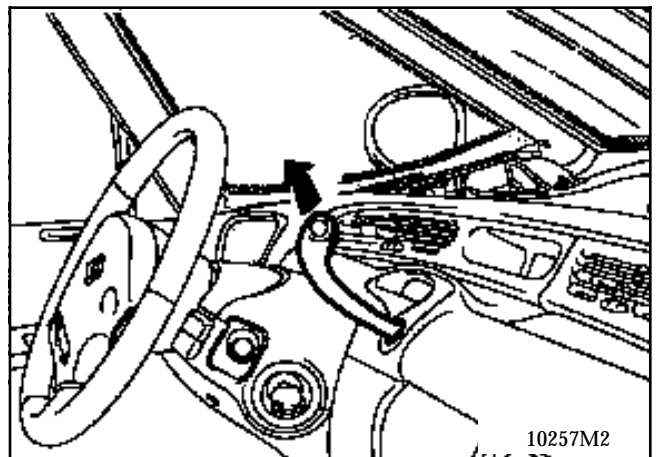
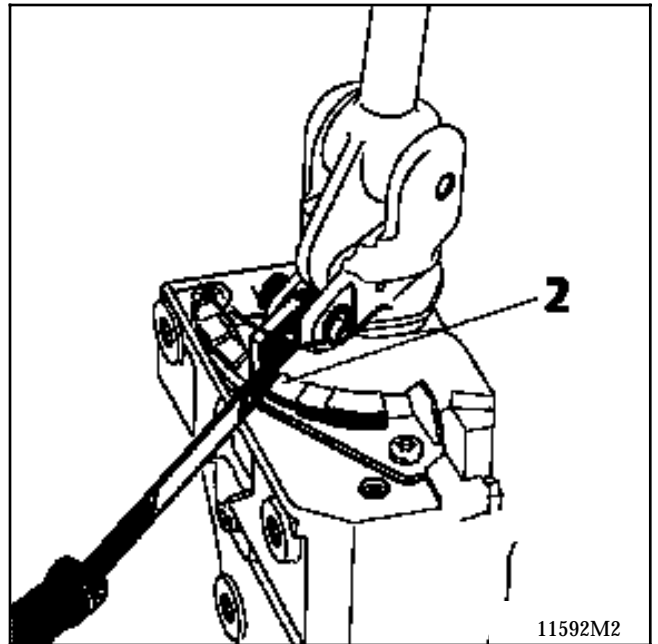

Check that the lever moves between the various positions correctly ("gears").

Refitting is the reverse of removal.

Pay attention to the special notes which follow for the central storage compartment.

This is a delicate operation.

Attach the storage compartment between the passenger air bag and the steering column flange paying attention to the flip levers and by connecting the light cable.

Fit the antenna and radio remote control cables.

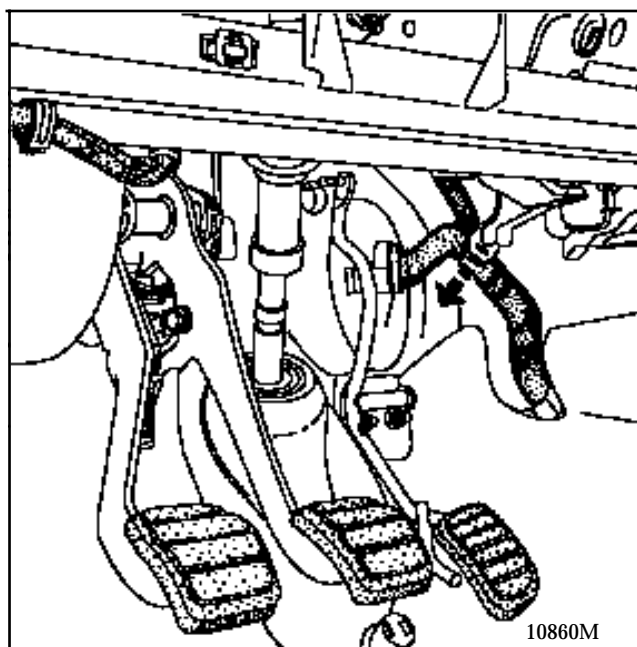

Check that there is no interference between the passenger compartment wiring loom and the lower left hand angle of the storage tray.

Connect the light.

Refitting is the reverse of removal.

REMOVAL

Removal/refitting of the condenser requires the cooling assembly to be removed.

See **Section 19 "cooling assembly"**.

REMOVAL

Disconnect the battery.

Place the vehicle on a lift.

Drain the R134a from the circuit.

Remove:

- the right hand wheel arch protector,
- the bumper,
- the pipe mounting bolts on the canister.

Fit plugs.

Disconnect the trifunction pressostat connector.

Remove:

- the mounting bolt from the canister on the condenser,

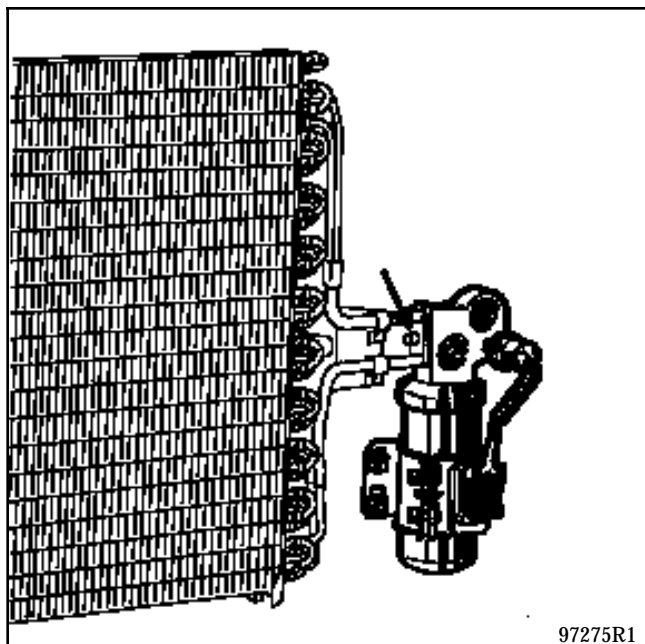

- the canister mounting bolts on the cooling assembly.

Remove the canister from below.

REFITTING

Refitting is the reverse of removal.

Check the condition of the seals, lubricate before fitting.

Drain using a vacuum pump then fill the circuit with **R134 A** using the filling station.

IMPORTANT: when replacing the dehydration canister, **add 15 ml of Sanden SP10 oil.**

Quantity of R134a : 890 ± 25 g.

Replace the dehydration canister whenever a component breaks or whenever the circuit is exposed to the open air for more than **10 minutes.**

The refrigerant fluid pipes at the bulkhead are equipped with quick release unions.

SEPARATING METHOD

Drain the R134a from the circuit using the filling station.

On the pipe without a union, fit **Mot. 1410** which is best suited to the diameter of the pipe.

Pull the tool towards yourself to move the internal locking spring to one side and pull on the pipes at the same time to unclip them.

Fit plugs.

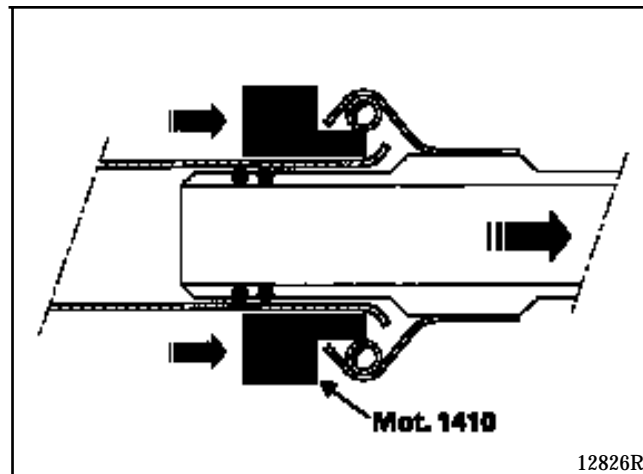

REFITTING

Clip the unions without using a tool, by clipping them into the rigid tubes

Check the condition of the seals and lubricate before fitting.

Disconnect the battery.

Drain the R134a from the circuit using the filling station.

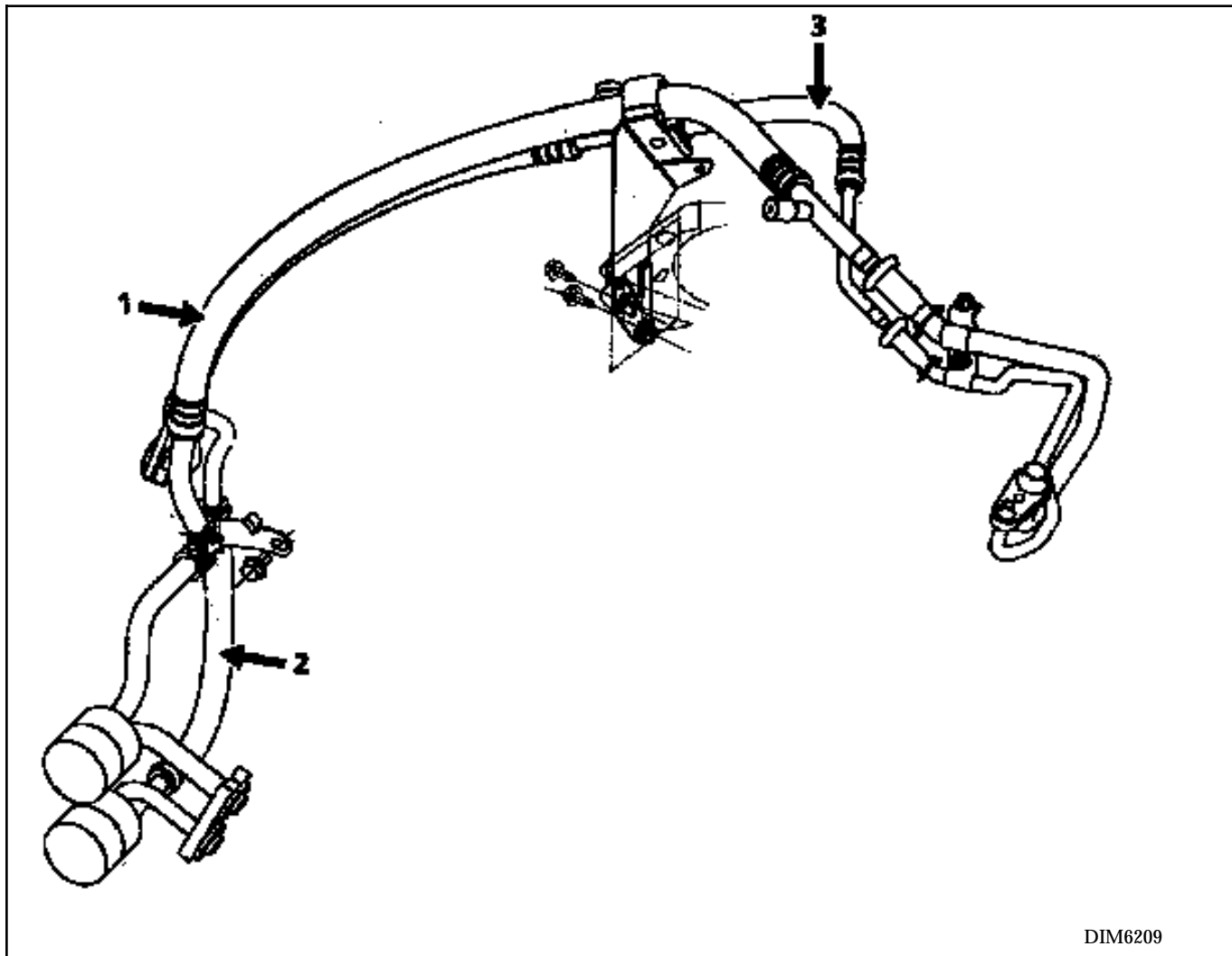

DIM6209

Low pressure pipe (1)

REMOVAL

Place the vehicle on a lift.

Remove the pipe mounting on the shock absorber turret.

UNDER THE VEHICLE

Remove:

- the right hand side wheel arch plastic protector,
- the pipe mounting bolt on the compressor.

Fit plugs to the compressor and the pipes.

FROM ABOVE

Unclip the low pressure pipe using **Mot. 1410**.

Remove the low pressure pipe.

Disconnect the battery.

Drain the R134a from the circuit using the filling station.

High pressure pipe between compressor and condenser (2)

REMOVAL

Place the vehicle on a lift.

Remove:

- the right hand wheel arch plastic protector,
- the mounting bolt for the pipes on the compressor and condenser.

Fit plugs on the compressor and the condenser.

Remove the pipe.

High pressure pipe between dehydration canister and pressure relief valve (3)

REMOVAL

Place the vehicle on a lift.

Remove:

- the right hand wheel arch plastic protector,
- the mounting bolt for the pipes on the dehydration canister,

FROM ABOVE.

Remove the pipe mounting bolt on the shock absorber turret.

Unclip the high pressure pipe using **Mot. 1410**.

Fit plugs.

Remove the high pressure pipe.

REFITTING THE PIPES

Refitting is the reverse of removal.

Check the condition of the seals and lubricate with **Sanden SP10 oil**.

When replacing a pipe, **add 10 ml of Sanden SP10 oil** or add **100 ml** of oil if a pipe has burst.

REMOVAL

Drain the R134a from the circuit using the filling station.

Disconnect the battery.

Place the vehicle on a lift.

Remove:

- the right hand wheel arch plastic protector,
- the accessories belt (see **Section 07**),
- the mounting bolt for the pipes on the compressor,
- the rear compressor mounting bolts.

Disconnect the clutch feed wire.

Remove the the front compressor mounting bolts.

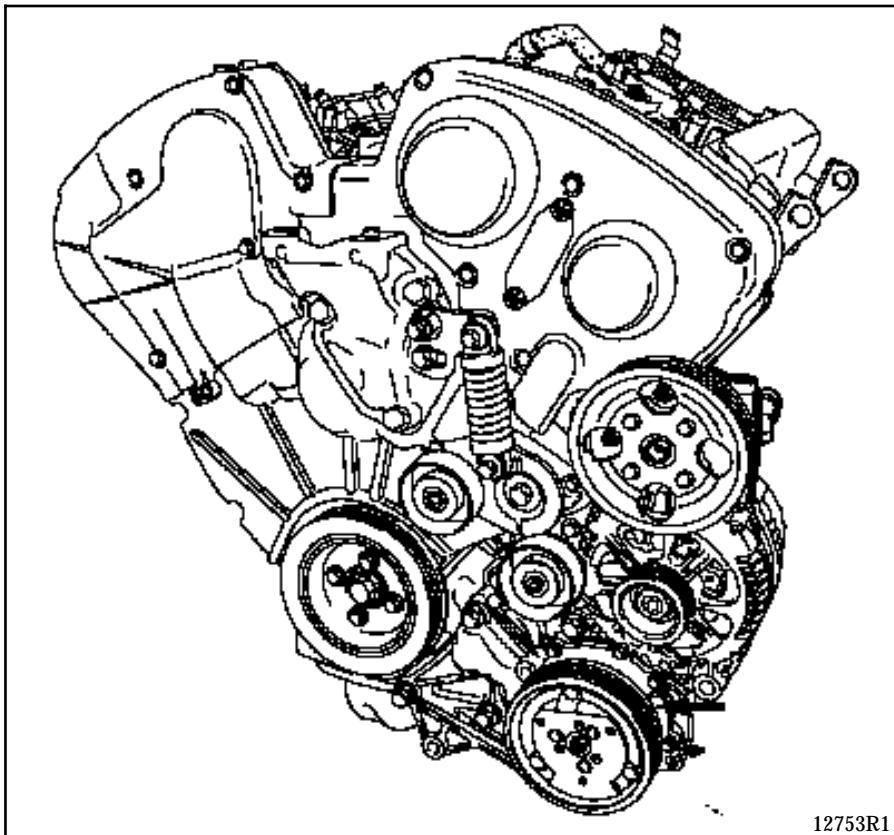

REFITTING

Refitting is the reverse of removal.

Follow the recommendations in section 07 for refitting the accessories belt.

Quantity of SP 10 oil in the circuit:

135 cm³

Quantity of R134a refrigerant:

890 ± 25g